

**ENGINEERING CATALOG**

# The Power to Build



## Power-Strut® Metal Framing...



**CHANNEL**



**CLAMPING NUT**



**CONNECTION  
FITTING**



**BOLT**

The present line of Power-Strut continuous slot metal framing is the result of over one half century of experience in metal framing. This complete line includes channels, fittings and accessories of American manufacture for any framing or support problem... large or small, heavy or light.

Power-Strut is proud of the exacting standards of research, design, engineering and manufacturing that go into production of the Power-Strut system. Maximum recommended load ratings for channels have been established through testing and are based on allowable stresses applicable to the Power-Strut Material Specification. Many Power-Strut products are listed by the Underwriters' Laboratories, Inc. and certified by the Canadian Standards Association.

## The Power-Strut Connection, Easy as 1 - 2 - 3...



Insert the clamping nut anywhere along the continuous slot channel. A 90° clockwise turn positions the grooves and teeth in the nut with the inturned edges of the channel

















The Power-Strut fitting provides the connection of channels



Tighten the bolt(s) to secure the connection





---

	<b>General Information</b> .....	<b>Page 2</b>
	<b>Channel</b> .....	<b>Page 6</b>
	<b>Fasteners</b> .....	<b>Page 41</b>
	<b>Fittings</b> .....	<b>Page 48</b>
	<b>Trolleys</b> .....	<b>Page 74</b>
	<b>Pipe &amp; Conduit Clamps</b> .....	<b>Page 76</b>
	<b>Brackets</b> .....	<b>Page 81</b>
	<b>Rollers</b> .....	<b>Page 86</b>
	<b>Beam Clamps</b> .....	<b>Page 89</b>
	<b>Electrical</b> .....	<b>Page 97</b>
	<b>Concrete Inserts</b> .....	<b>Page 114</b>
	<b>Heavy Duty Channel &amp; Inserts</b> .....	<b>Page 119</b>
	<b>Jr. Channel</b> .....	<b>Page 123</b>
	<b>Technical Data</b> .....	<b>Page 130</b>
	<b>Example Applications</b> .....	<b>Page 148</b>
	<b>Product Index</b> .....	<b>Page 152</b>

**Warning:** Power-Strut products are carefully designed and manufactured to the listed standards, as applicable. However, Power-Strut reserves the right to revise product design without notification. Power-Strut products included in this catalog are intended for installation and service only as described or specified herein. Care should be exercised by installers and end-users to install, use and maintain these products properly to avoid an possible on-the-job accidents.

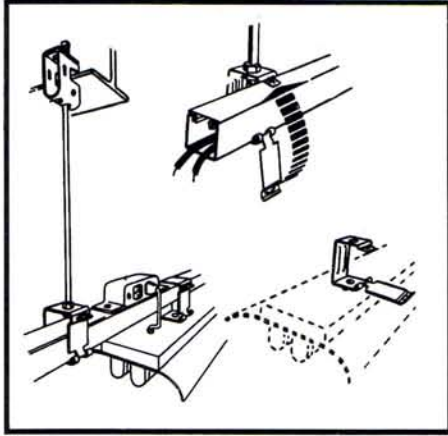

## A BROAD AND VERSATILE METAL FRAMING LINE,



### *More Than 8,000 Quality Products*

The Power-Strut metal framing system can be regarded as a basic building material. Our metal framing system is an erector set concept, using channel and fittings to solve many applications. You can conceal metal framing in the basic structure of a building or run it along the surface of walls, ceilings and floors. An endless array of fittings provide freedom to work at virtually any angle along any surface to shape a support system that fits your exact needs.

Available finishes include hot-dipped galvanized, pre-galvanized, electro-galvanized and painted, along with material choices of steel, stainless steel and aluminum.

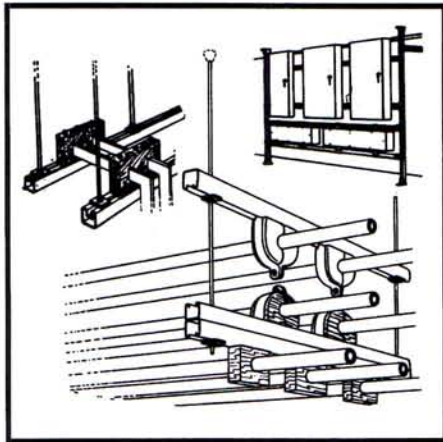

Beyond its versatility as a basic building material, metal framing is popular for more exotic applications such as clean rooms, satellite dish supports, x-ray supports, storage racks, theater screens, tunnel stanchions and offshore platform catwalks. While the uses of metal framing are truly unlimited, they fall into three major categories.

### *Electrical Systems*

Versatile metal framing is widely used by electrical contractors to support conduit, panel boxes, raceway systems and other electrical components. In addition, Power-Strut channel can be used as a wiring raceway. Products marked with the UL symbol in this catalog are listed by Underwriter's Laboratories for use in raceway applications.

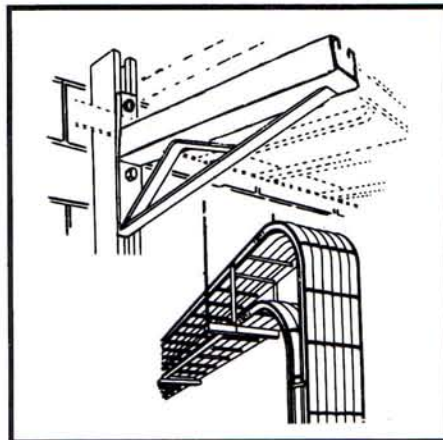

Channel raceways or support systems can be attached to ceilings, wood or steel beams, inside columns or imbedded in concrete. Trapeze systems can support conduit from either the top or bottom.

As a lighting support system, metal framing helps assure proper alignment over long spans. As a raceway system, channel offers an opportunity to reduce construction costs through more efficient use of installation labor. The exceptional versatility of channel gives contractors more flexibility in solving miscellaneous problems which may arise at the job site.

## BACKED BY A LEADING REPUTATION FOR QUALITY AND SERVICE.

---

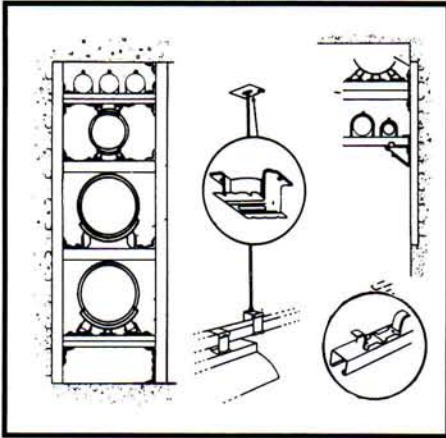

### ***Mechanical Systems That Reduce Costs***

For mechanical support of HVAC, plumbing and fire protection systems, the versatility of metal framing systems is unmatched. It is by far the most popular framing system with contractors because the wide variety of fittings and support devices available help solve virtually any support problem without expensive welding.

Piping stanchions, ceiling and wall-mounted supports and tunnel supports are common metal framing applications. Concrete insert, shelf bracket, wall and ceiling-mounted systems provide flexible solutions to any piping support applications.

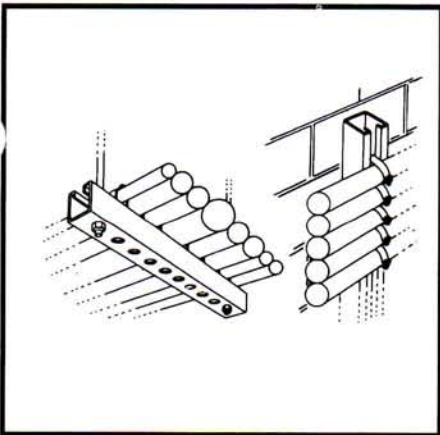

In addition, pipe support products such as Power-Wrap and cushioned clamps provide insulation to prevent potential damage from noise, vibration, temperature variations and metal-to-metal contact.

### ***OEM Components And Maintenance***

Metal Framing systems provide convenient solutions for maintenance and retrofit requirements in processing and manufacturing facilities. Also, Power-Strut products can be used as cost-effective components in OEM applications. For example, channel can be used as conveyor stands and side rails or provide framing for panel cabinetry products, or for generator, motor and pump supports.

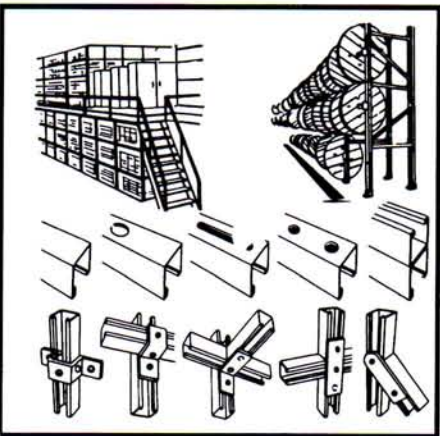

The complete line of products and leading reputation for quality and service make Power-Strut your practical choice for metal framing. Contact your local Power-Strut representative for additional information.

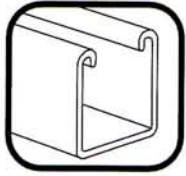

## POWER-STRUT MATERIAL SPECIFICATIONS

### MATERIALS:

#### **Channel\* & Closures – Pre-Galvanized**

ASTM A653 Grade 33, Steel Sheet Zinc Coated by Hot Dip Process

#### **Channel\* – Plain, Painted or Hot Dip Galvanized**

ASTM A-570 Grade 33, Hot Rolled Carbon Steel Sheet and Strip, Structural Quality

#### **Channel\* – Stainless Steel**

ASTM A-240, Type 304, Heat Resisting Chromium and Chromium-Nickel Stainless Steel Plate, Sheet, Strip for Pressure Vessel

#### **Channel\* – Aluminum**

ASTM B-221, Type 6063 T6, Aluminum Alloy Extruded Bar, Rod, Wire, Shape and Tube

#### **Closures – Plain, Painted or Hot Dip Galvanized**

ASTM A366, Steel, Strip, Carbon, Cold-Rolled

#### **Fittings\* – Steel**

- 1/4" Nominal Thickness – ASTM A-575 and A576†
- 3/8" Nominal Thickness – A36 (Structural Steel)

#### **Fittings\* – Aluminum**

ASTM B-209

#### **Accessories – Steel**

- Less than 1/4" Nominal Thickness – ASTM A-569, 1008-1010 Grade, or (when Pre-Galvanized) ASTM A-527/Coating Designation G90

#### **Pipe Clamps – Steel**

A-570 Grade 33

#### **Pipe Clamps – Stainless Steel**

ASTM A-240, Type 304

#### **Pipe Clamps – Aluminum**

ASTM B-209, 5052, H32 Grade, Sheet and Plate

#### **Channel Nuts**

ASTM (3/8" & 1/2") A-576 Grade 1015M, A-675 (1/4") Grade 60, Case Hardened to RC25 min.

#### **Hex Nuts and Bolts**

ASTM A-563, Grade A and ASTM A-307, Grade A

#### **Threaded Rod**

ASTM A-510, Hot Rolled, 1008-1010 Grade

\* Channel referenced is 1 5/8" wide, fittings referenced are for 1 5/8" channel.

† Some 1/4" fittings are produced from A-36 Structural Steel.



---

## POWER-STRUT FINISH SPECIFICATIONS

### FINISHES:

#### **Channel and Closures – Pre Galvanized**

ASTM A-525, Grade 90 Gen. Requirement for Steel Sheet, Zinc-Coated (Galvanized) by Hot Dip Process

#### **Channel, Closures and Fittings – Power-Green™**

Acrylic enamel applied by electro-deposition process

#### **Channel and Closures – Hot Dip Galvanized After Fabrication**

ASTM A-123, Zinc Coating (Hot Dip) on Iron and Steel

#### **Bolts, Nuts, Clamps and Fittings – Electroplated (EG)**

ASTM B-633, SC1 Electroplated Coatings of Zinc on Iron and Steel

#### **Bolts, Nuts, Clamps and Fittings – Hot Dip Galvanized After Fabrication**

ASTM A-153 or ASTM A-123, Zinc Coatings (Hot Dip) on Iron and Steel Hardware

### FINISHES (Ordering):

When ordering, add the finish to the part number. For example, PS 200-10 PGL.

The abbreviation for available finishes:

**GRN** ..... Painted Green  
**EG** ..... Electro-Galvanized  
**PGL** ..... Pre-Galvanized  
**ALM** ..... Aluminum  
**HDG** ..... Hot Dipped Galvanized  
**SS** ..... Stainless Steel  
**PLN** ..... Plain



# CHANNEL



## MATERIALS & MANUFACTURING SPECIFICATIONS – STANDARD CHANNEL

### **GENERAL:**

Power-Strut channel sections are produced by multiple sets of forming rolls which cold-work strip steel into the channel configuration. This type of roll forming produces a uniform channel section held to the specifications of MFMA -2.

### **MATERIALS:**

Plain and painted green channels are formed from structural quality strip steel which conforms to the requirements of ASTM A-570 Grade 33. Pre-galvanized channel conforms to the requirements of ASTM A-653 Grade 33.

### **STANDARD LENGTHS:**

Stock lengths are 10 and 20 feet. Special lengths are available upon request.

### **STANDARD FINISHES:**

Standard Power-Strut channel is available in plain, painted green or pre-galvanized finishes.

### **ORDERING INFORMATION:**

When ordering, add the length or size and finish to the part number. See page 5 for finish abbreviations and an example.

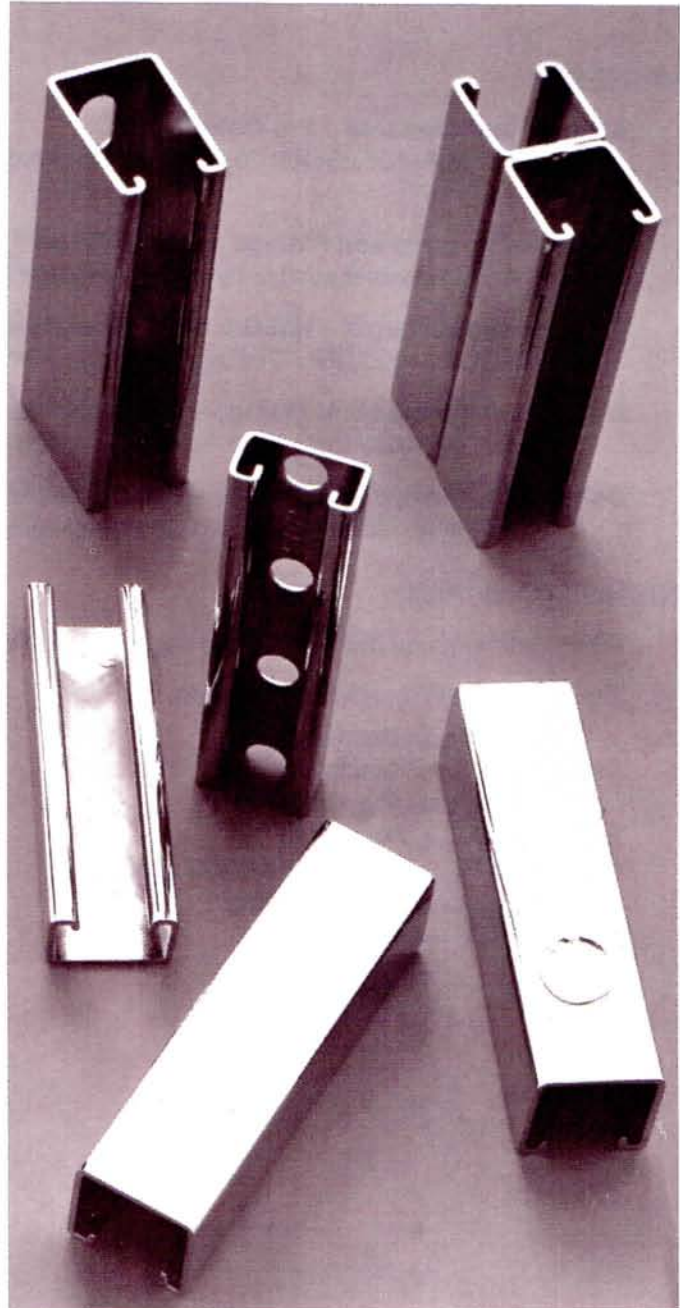



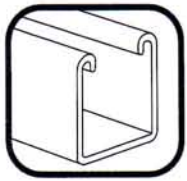

**PS 100** – 1 5/8" x 3 1/4" x 12 ga.

*See Pages 8-10*

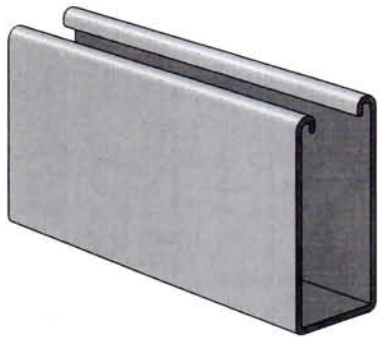

**PS 150** – 1 5/8" x 2 7/16" x 12 ga.

*See Pages 11-13*

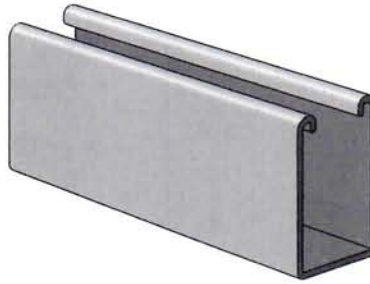

**PS 200** – 1 5/8" x 1 5/8" x 12 ga.

*See Pages 14-21*

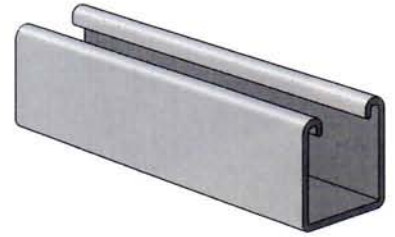

**PS 210** – 1 5/8" x 1 5/8" x 14 ga.

*See Pages 22-24*

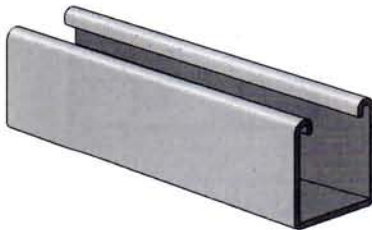

**PS 300** – 1 5/8" x 1 3/8" x 12 ga.

*See Pages 25-27*

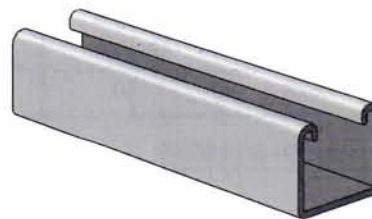

**PS 400** – 1 5/8" x 1" x 12 ga.

*See Pages 28-30*



**PS 500** – 1 5/8" x 13/16" x 14 ga.

*See Pages 31-33*

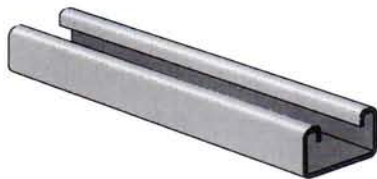

**PS 520** – 1 5/8" x 13/16" x 12 ga.

*See Pages 34-36*

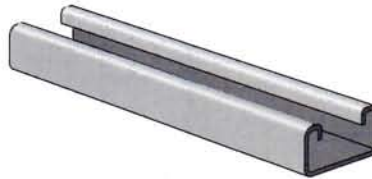

**PS 560** – 1 5/8" x 13/16" x 16 ga.

*See Pages 37-39*



**PIERCED SECTIONS**

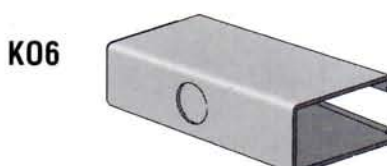
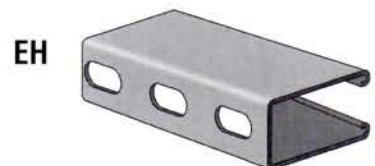
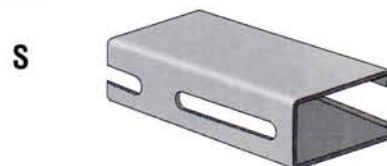
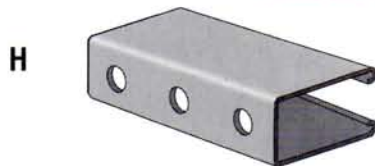

# CHANNEL



**General Information**  
 Finish: Plain, painted green or pre-galvanized  
 Stock Length: 10' and 20', other lengths on request  
 Order By: Part No., Length & Finish



## PS 100 – Steel Channel (1 5/8" x 3 1/4" x 12 ga.)

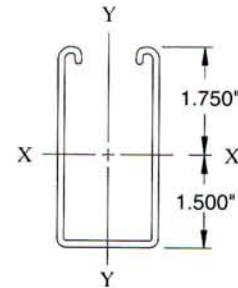
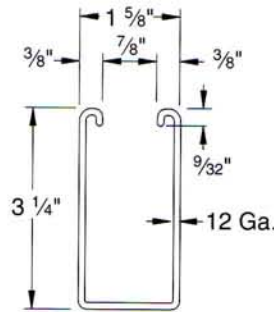
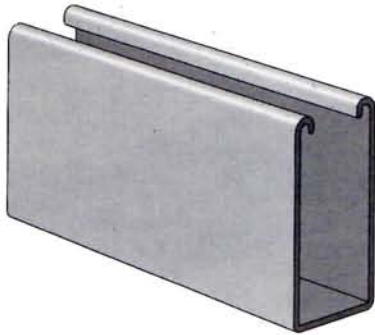

### ELEMENTS OF SECTION

Weight (lbs./100 ft.)	Area of Section (Inch <sup>2</sup> )	X-X Axis			Y-Y Axis		
		Moment of Inertia (Inch <sup>4</sup> )	Section Modulus (Inch <sup>3</sup> )	Radius of Gyration (Inch)	Moment of Inertia (Inch <sup>4</sup> )	Section Modulus (Inch <sup>3</sup> )	Radius of Gyration (Inch)
305	.897	1.099	.628	1.107	.359*	.442*	.695

Modulus of Elasticity: 29,000,000 PSI; \*Effective section properties

### PS 100 H – Channel with Holes

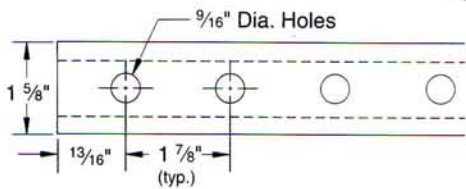
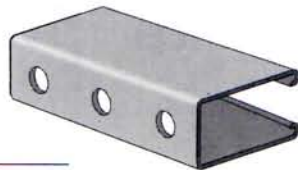

Weight: 300 lbs./100 ft.

### PS 100 EH – Channel with Elongated Holes

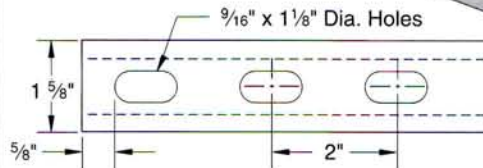
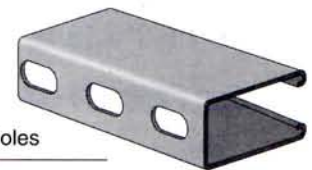

Weight: 300 lbs./100 ft.

### PS 100 S – Channel with Slots

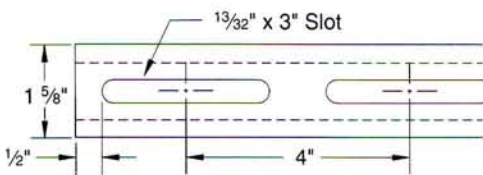

Weight: 300 lbs./100 ft.

### PS 100 K06 – Channel with Knockouts

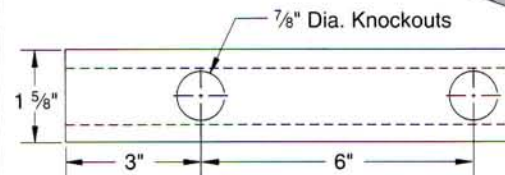
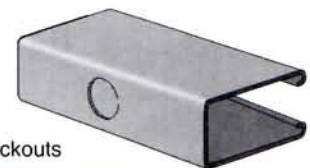

Weight: 305 lbs./100 ft.



General Information  
 Finish: Plain, painted green or pre-galvanized  
 Stock Length: 10' and 20', other lengths on request  
 Order By: Part No., Length & Finish

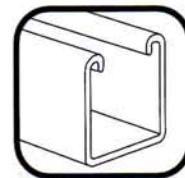

**PS 100 – Beam & Column Loads**

Span, or Column Inches	Column Load	Dynamic Beam Load X-X Axis	Static Beam Load X-X Axis		
	Maximum Load Lbs.	Uniform Load Lbs. @ 12,000 PSI Stress	Uniform Load Lbs. @25,000 PSI Stress	Deflection Inches @25,000 PSI Stress	Uniform Load Lbs @ 1/240 Span Deflection
12	13,000	5,050 *	10,530 *	0.01	–
18	12,530	3,370	7,020 *	0.02	–
24	11,870	2,530	5,260 *	0.03	–
30	9,950	2,020	4,210 *	0.05	–
36	8,050	1,680	3,510	0.07	–
42	6,530	1,440	3,010	0.09	–
48	5,020	1,260	2,630	0.12	–
54	4,300	1,120	2,340	0.15	–
60	3,590	1,010	2,110	0.18	–
66	3,190	920	1,910	0.22	–
72	2,800	840	1,750	0.26	–
84	2,310	720	1,500	0.36	1,470
96	1,980	630	1,320	0.47	1,130
108	1,730	560	1,170	0.59	890
120	1,550	510	1,050	0.73	720

For Pierced Channels, reduce beam load values as follows:

- PS-100-EH 15%
- PS-100-S 15%
- PS-100-H 10%
- PS-100-K06 5%

Column loads are for allowable axial loads and must be reduced for eccentric loading. For concentrated load at center of span, divide uniform load by 2 and multiply corresponding deflection by 0.8. Dynamic loads should be used for design when the channel is used for support of plumbing, heating, process or power piping. This load table is based on a solid channel section.

\* Bearing load may govern capacity.

**PS 100 – CRUSH LOADS**

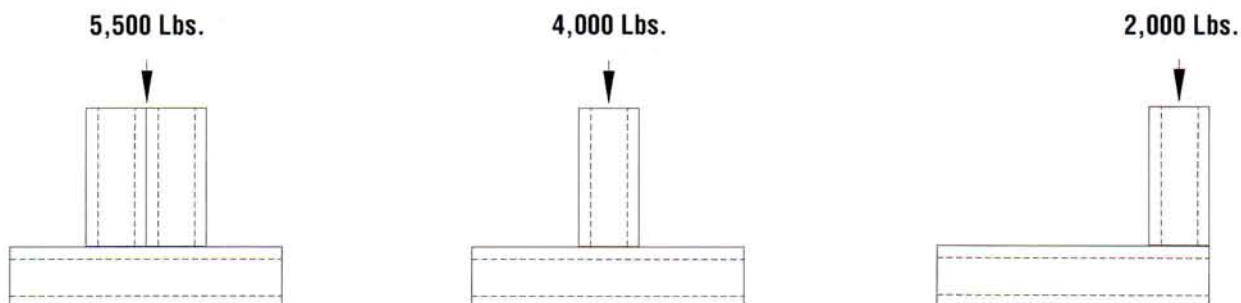

**Resistance to Slip:** 1,500 lbs. per bolt when 1/2" PS NS channel nuts are used.  
**Pull Out Strength:** 2,000 lbs. per bolt when 1/2" PS NS channel nuts are used.

# CHANNEL

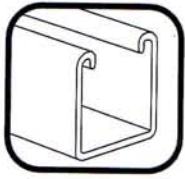

General Information  
 Finish: Plain, painted green or pre-galvanized  
 Stock Length: 10' and 20', other lengths on request  
 Order By: Part No., Length & Finish



## PS 100 2T3 – Steel Channel (1 5/8" x 6 1/2" x 12 ga.)

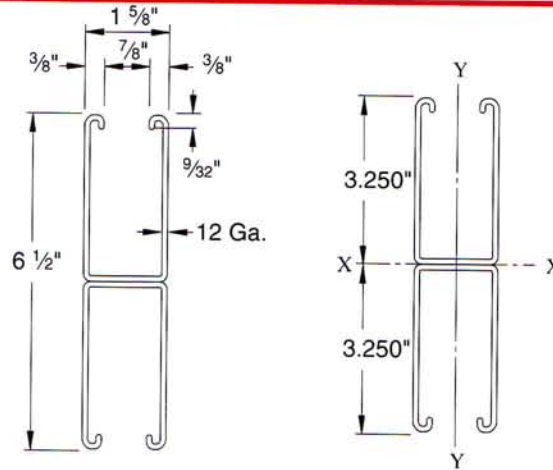
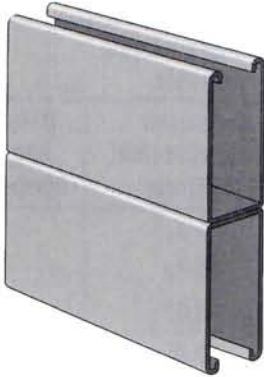

### ELEMENTS OF SECTION

Weight (lbs./100 ft.)	Area of Section (Inch <sup>2</sup> )	X-X Axis			Y-Y Axis		
		Moment of Inertia (Inch <sup>4</sup> )	Section Modulus (Inch <sup>3</sup> )	Radius of Gyration (Inch)	Moment of Inertia (Inch <sup>4</sup> )	Section Modulus (Inch <sup>3</sup> )	Radius of Gyration (Inch)
610	1.794	5.578*	1.716*	1.864	.719*	.884*	.695

Modulus of Elasticity: 29,000,000 PSI; \*Effective section properties

### BEAM & COLUMN LOADS

Span, or Column Inches	Column Load	Dynamic Beam Load X-X Axis	Static Beam Load X-X Axis		
	Maximum Load Lbs.	Uniform Load Lbs. @ 12,000 PSI Stress	Uniform Load Lbs. @25,000 PSI Stress	Deflection Inches @25,000 PSI Stress	Uniform Load Lbs @ 1/240 Span Deflection
12	30,570	6,170 *†	6,170 *†	0.00	–
18	30,250	6,170 *†	6,170 *†	0.01	–
24	29,790	5,430 †	6,170 *†	0.01	–
30	29,210	4,340 †	6,170 *†	0.02	–
36	28,490	3,620	6,170 *†	0.03	–
42	27,640	3,100	6,170 *†	0.04	–
48	26,670	2,710	5,650 †	0.05	–
54	25,560	2,410	5,020 †	0.07	–
60	24,320	2,170	4,520 †	0.08	–
66	22,960	1,970	4,110 †	0.10	–
72	21,460	1,810	3,770	0.11	–
84	18,070	1,550	3,230	0.15	–
96	14,260	1,360	2,830	0.20	–
108	11,270	1,210	2,510	0.25	–
120	9,130	1,090	2,260	0.31	–

\* Load limited by spot weld shear. † Bearing load may govern capacity.



**General Information**

Finish: Plain, painted green or pre-galvanized  
 Stock Length: 10' and 20', other lengths on request  
 Order By: Part No., Length & Finish



**PS 150 – Steel Channel (1 5/8" X 2 7/16" X 12 GA.)**

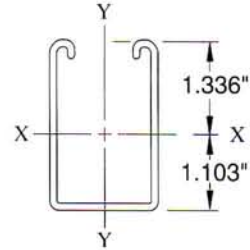
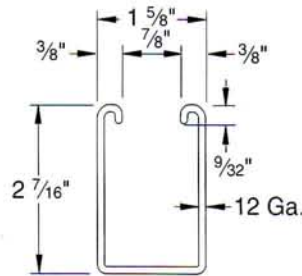
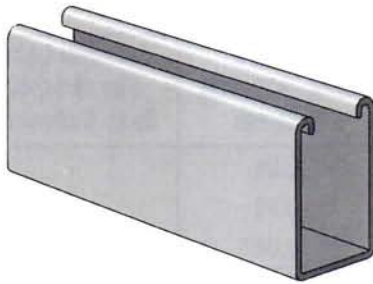

**ELEMENTS OF SECTION**

Weight (lbs./100 ft.)	Area of Section (Inch <sup>2</sup> )	X-X Axis			Y-Y Axis		
		Moment of Inertia (Inch <sup>4</sup> )	Section Modulus (Inch <sup>3</sup> )	Radius of Gyration (Inch)	Moment of Inertia (Inch <sup>4</sup> )	Section Modulus (Inch <sup>3</sup> )	Radius of Gyration (Inch)
247	.726	.523	.391	.848	.335	.412	.679

Modulus of Elasticity: 29,000,000 PSI

**PS 150 H – Channel with Holes**

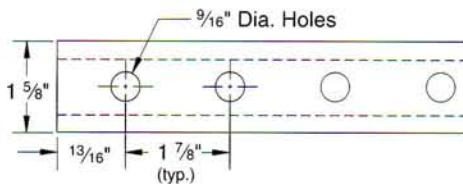
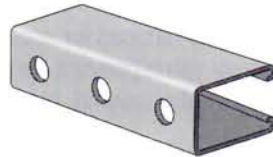

Weight: 242 lbs./100 ft.

**PS 150 EH – Channel with Elongated Holes**

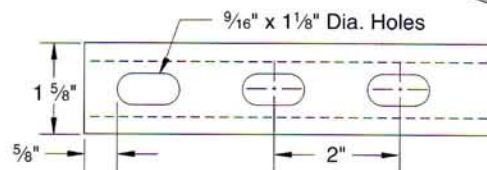
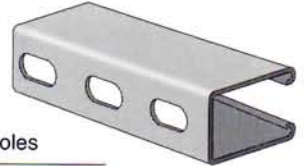

Weight: 242 lbs./100 ft.

**PS 150 S – Channel with Slots**

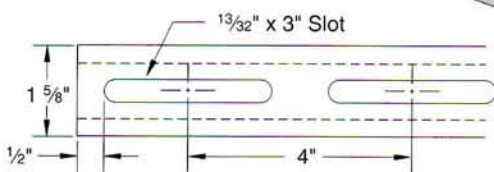
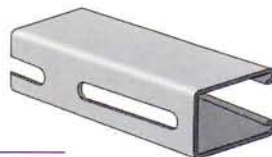

Weight: 242 lbs./100 ft.

**PS 150 KO6 – Channel with Knockouts**

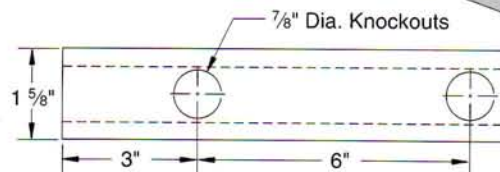
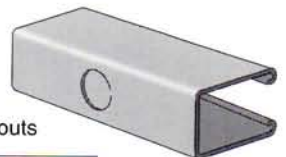

Weight: 247 lbs./100 ft.

# CHANNEL

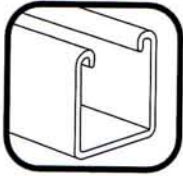

**General Information**  
 Finish: Plain, painted green or pre-galvanized  
 Stock Length: 10' and 20', other lengths on request  
 Order By: Part No., Length & Finish



## PS 150 – Beam & Column Loads

Span, or Column Inches	Column Load	Dynamic Beam Load X-X Axis	Static Beam Load X-X Axis		
	Maximum Load Lbs.	Uniform Load Lbs. @ 12,000 PSI Stress	Uniform Load Lbs. @25,000 PSI Stress	Deflection Inches @25,000 PSI Stress	Uniform Load Lbs @ 1/240 Span Deflection
12	13,570	3,150	6,550 *	0.01	–
18	12,750	2,100	4,370	0.02	–
24	11,710	1,570	3,280	0.04	–
30	9,730	1,260	2,620	0.06	–
36	7,760	1,050	2,180	0.09	–
42	6,440	900	1,870	0.12	–
48	5,130	790	1,640	0.15	–
54	4,400	700	1,460	0.19	–
60	3,860	630	1,310	0.24	–
66	3,450	570	1,190	0.29	1,130
72	3,120	520	1,090	0.34	950
84	2,630	450	940	0.47	700
96	2,280	390	820	0.61	540
108	2,000	350	730	0.77	420
120	1,770	310	660	0.96	340

For Pierced Channels, reduce beam load values as follows:

- PS-150-EH 15%
- PS-150-S 15%
- PS-150-H 10%
- PS-150-K06 5%

Column loads are for allowable axial loads and must be reduced for eccentric loading. For concentrated load at center of span, divide uniform load by 2 and multiply corresponding deflection by 0.8. Dynamic loads should be used for design when the channel is used for support of plumbing, heating, process or power piping. This load table is based on a solid channel section.

\* Bearing load may govern capacity.

## PS 150 – CRUSH LOADS

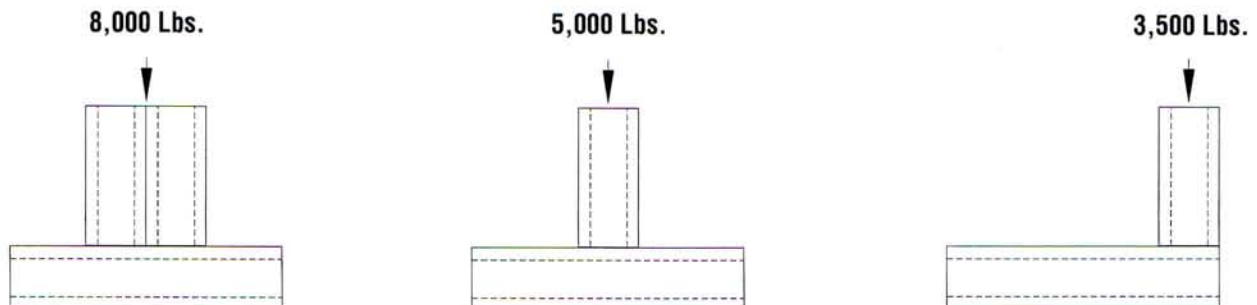

**Resistance to Slip:** 1,500 lbs. per bolt when 1/2" PS NS channel nuts are used.  
**Pull Out Strength:** 2,000 lbs. per bolt when 1/2" PS NS channel nuts are used.



**General Information**

Finish: Plain, painted green or pre-galvanized  
 Stock Length: 10' and 20', other lengths on request  
 Order By: Part No., Length & Finish



**PS 150 2T3 – Steel Channel (1 5/8" x 4 7/8" x 12 ga.)**

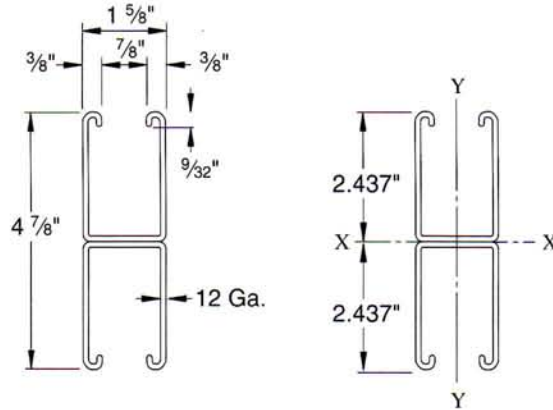
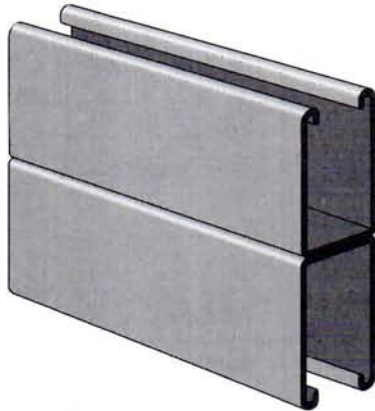

**ELEMENTS OF SECTION**

Weight (lbs./100 ft.)	Area of Section (Inch <sup>2</sup> )	X-X Axis			Y-Y Axis		
		Moment of Inertia (Inch <sup>4</sup> )	Section Modulus (Inch <sup>3</sup> )	Radius of Gyration (Inch)	Moment of Inertia (Inch <sup>4</sup> )	Section Modulus (Inch <sup>3</sup> )	Radius of Gyration (Inch)
494	1.453	2.811	1.153	1.391	.669	.824	.679

Modulus of Elasticity: 29,000,000 PSI

**BEAM & COLUMN LOADS**

Span, or Column Inches	Column Load	Dynamic Beam Load X-X Axis	Static Beam Load X-X Axis		
	Maximum Load Lbs.	Uniform Load Lbs. @ 12,000 PSI Stress	Uniform Load Lbs. @25,000 PSI Stress	Deflection Inches @25,000 PSI Stress	Uniform Lbs @ 1/240 Span Deflection
12	31,000	4,680 *	4,680 *	0.00	–
18	30,740	4,680 *	4,680 *	0.01	–
24	30,350	4,640	4,680 *	0.01	–
30	29,450	3,710	4,680 *	0.02	–
36	28,560	3,090	4,680 *	0.04	–
42	27,310	2,650	4,680 *	0.06	–
48	26,060	2,320	4,680 *	0.08	–
54	24,440	2,060	4,300	0.11	–
60	22,830	1,860	3,870	0.13	–
66	20,860	1,690	3,520	0.16	–
72	18,900	1,550	3,220	0.19	–
84	14,400	1,330	2,760	0.26	–
96	11,020	1,160	2,420	0.34	–
108	8,710	1,030	2,150	0.43	–
120	7,050	930	1,930	0.53	1,840

\*Load limited by spot weld shear.

# CHANNEL

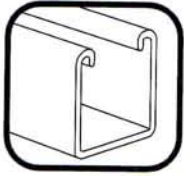

**General Information**  
 Finish: Plain, painted green or pre-galvanized  
 Stock Length: 10' and 20', other lengths on request  
 Order By: Part No., Length & Finish



## PS 200 – Steel Channel (1 5/8" x 1 5/8" x 12 ga.)

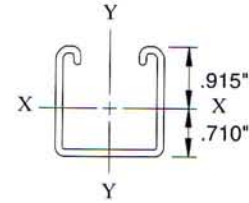
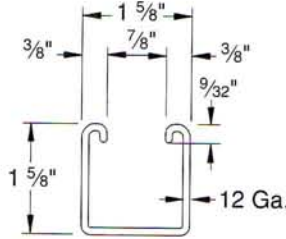
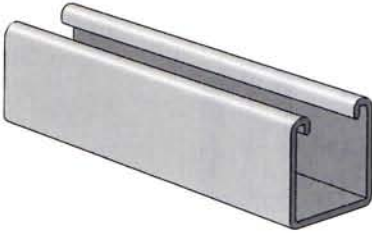

### ELEMENTS OF SECTION

Weight (lbs./100 ft.)	Area of Section (Inch <sup>2</sup> )	X-X Axis			Y-Y Axis		
		Moment of Inertia (Inch <sup>4</sup> )	Section Modulus (Inch <sup>3</sup> )	Radius of Gyration (Inch)	Moment of Inertia (Inch <sup>4</sup> )	Section Modulus (Inch <sup>3</sup> )	Radius of Gyration (Inch)
190	.556	.185	.202	.577	.236	.290	.651

Modulus of Elasticity: 29,000,000 PSI

### PS 200 H – Channel with Holes

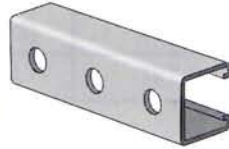
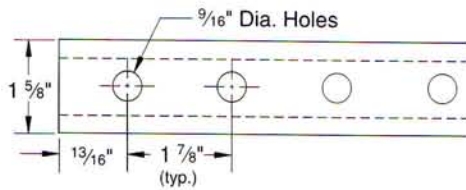

Weight: 186 lbs./100 ft.

### PS 200 EH – Channel with Elongated Holes

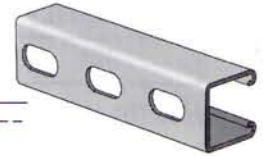
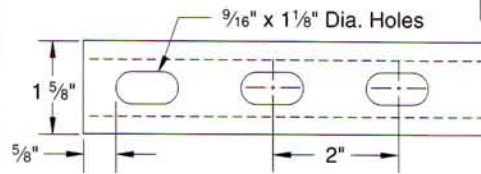

Weight: 185 lbs./100 ft.

### PS 200 H3 – Channel with Holes

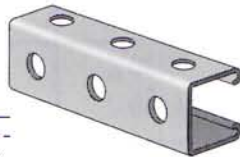
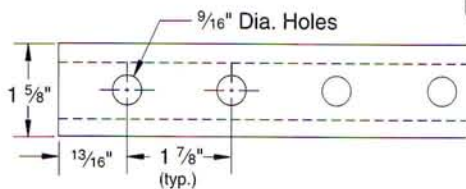

Weight: 175 lbs./100 ft.

### PS 200 K06 – Channel with Knockouts

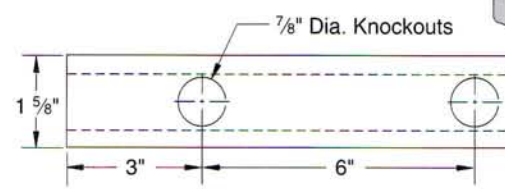

Weight: 190 lbs./100 ft.

### PS 200 S – Channel with Slots

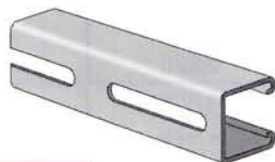
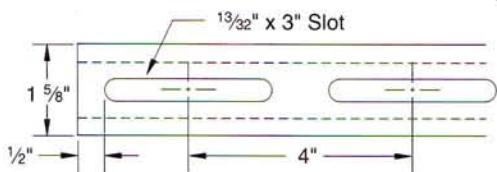

Weight: 185 lbs./100 ft.

### PS 200 SB – Channel with Slotted Back

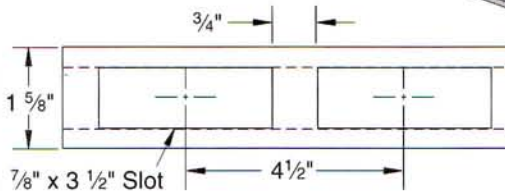

Weight: 173 lbs./100 ft.





General Information  
 Finish: Plain, painted green or pre-galvanized  
 Stock Length: 10' and 20', other lengths on request  
 Order By: Part No., Length & Finish

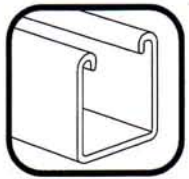

**PS 200 – Beam & Column Loads**

For Pierced Channels, reduce beam load values as follows:

- PS-200-EH 15%
- PS-200-S 15%
- PS-200-H 10%
- PS-200-K06 5%
- PS-200-SB 30%

For Extruded Aluminum Channels, reduce beam load values 38%.

Span, or Column Inches	Column Load	Dynamic Beam Load X-X Axis	Static Beam Load X-X Axis		
	Maximum Load Lbs.	Uniform Load Lbs. @ 12,000 PSI Stress	Uniform Load Lbs. @25,000 PSI Stress	Deflection Inches @25,000 PSI Stress	Uniform Lbs @ 1/240 Span Deflection
12	11,320	1,630	3,390	0.01	–
18	10,400	1,080	2,260	0.03	–
24	9,310	810	1,690	0.06	–
30	8,160	650	1,350	0.09	–
36	6,990	540	1,130	0.13	–
42	5,860	460	970	0.17	–
48	4,980	410	850	0.22	760
54	4,340	360	750	0.28	600
60	3,850	330	680	0.35	490
66	3,460	300	620	0.42	400
72	3,140	270	560	0.50	340
84	2,630	230	480	0.68	250
96	2,240	200	420	0.89	190
108	1,930	180	380	1.13	150
120	–	160	340	1.40	120

Column loads are for allowable axial loads and must be reduced for eccentric loading. For concentrated load at center of span, divide uniform load by 2 and multiply corresponding deflection by 0.8. Dynamic loads should be used for design when the channel is used for support of plumbing, heating, process or power piping. This load table is based on a solid channel section.

**PS 200 – Crush Loads**

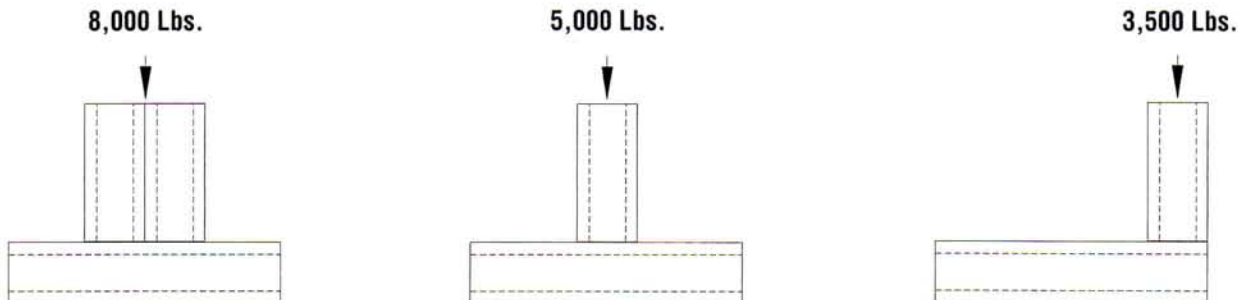

**Resistance to Slip:** 1,500 lbs. per bolt when 1/2" PS NS channel nuts are used.  
**Pull Out Strength:** 2,000 lbs. per bolt when 1/2" PS NS channel nuts are used.

# CHANNEL

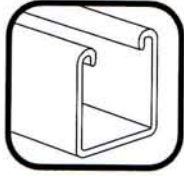

**General Information**  
 Finish: Plain, painted green or pre-galvanized  
 Stock Length: 10' and 20', other lengths on request  
 Order By: Part No., Length & Finish



## PS 200 2T3 – Steel Channel (1 5/8" x 3 1/4" x 12 ga.)

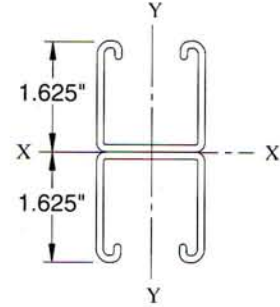
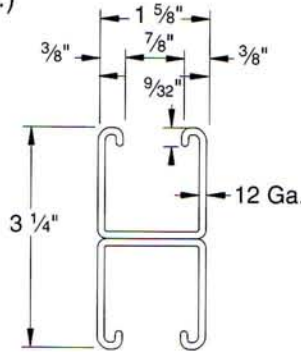
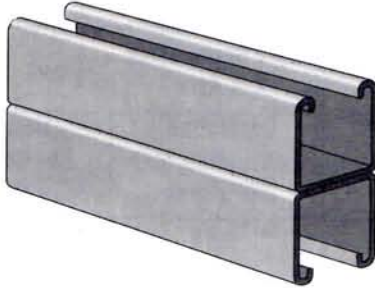

### ELEMENTS OF SECTION

Weight (lbs./100 ft.)	Area of Section (Inch <sup>2</sup> )	X-X Axis			Y-Y Axis		
		Moment of Inertia (Inch <sup>4</sup> )	Section Modulus (Inch <sup>3</sup> )	Radius of Gyration (Inch)	Moment of Inertia (Inch <sup>4</sup> )	Section Modulus (Inch <sup>3</sup> )	Radius of Gyration (Inch)
380	1.112	.930	.572	.915	.472	.580	.651

Modulus of Elasticity: 29,000,000 PSI

### BEAM & COLUMN LOADS

Span, or Column Inches	Column Load	Dynamic Beam Load X-X Axis	Static Beam Load X-X Axis		
	Maximum Load Lbs.	Uniform Load Lbs. @ 12,000 PSI Stress	Uniform Load Lbs. @25,000 PSI Stress	Deflection Inches @25,000 PSI Stress	Uniform Lbs @ 1/240 Span Deflection
12	24,030	3,130 *	3,130 *	0.01	–
18	23,650	3,070	3,130 *	0.01	–
24	23,130	2,300	3,130 *	0.02	–
30	22,460	1,840	3,130 *	0.04	–
36	21,640	1,530	3,130 *	0.07	–
42	20,670	1,320	2,740	0.10	–
48	19,560	1,150	2,400	0.13	–
54	18,290	1,020	2,130	0.16	–
60	16,870	920	1,920	0.20	–
66	15,310	840	1,740	0.24	–
72	13,590	770	1,600	0.29	–
84	10,130	660	1,370	0.39	1,240
96	7,750	580	1,200	0.51	950
108	6,130	510	1,070	0.64	750
120	4,960	460	960	0.79	610

\*Load limited by spot weld shear.



**General Information**  
 Finish: Plain, painted green or pre-galvanized  
 Stock Length: 10' and 20', other lengths on request  
 Order By: Part No., Length & Finish



**PS 200 2T2** – Welded Steel Channel (1 5/8" x 3 1/4" x 12 ga.)

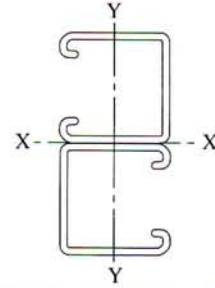
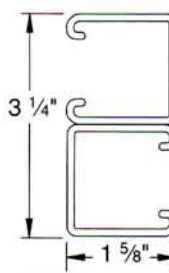
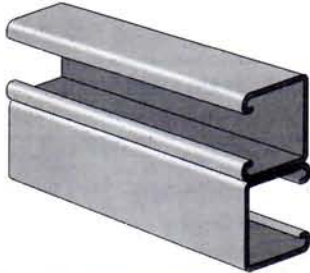

**PS 200 2T4** – Welded Steel Channel (1 5/8" x 3 1/4" x 12 ga.)

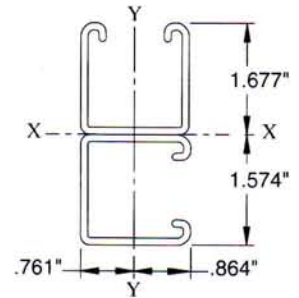
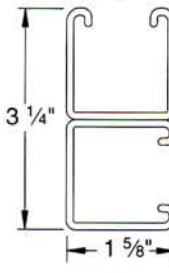
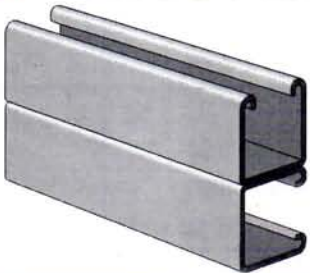

**PS 200 2T5** – Welded Steel Channel (1 5/8" x 3 1/4" x 12 ga.)

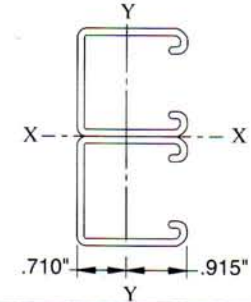
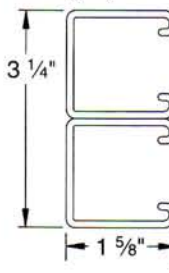
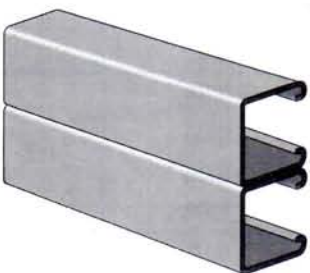

**PS 200 3T6** – Welded Steel Channel

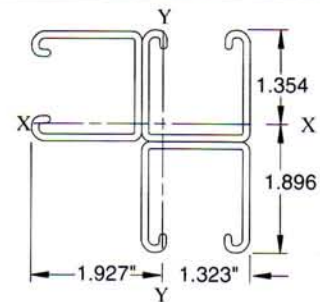
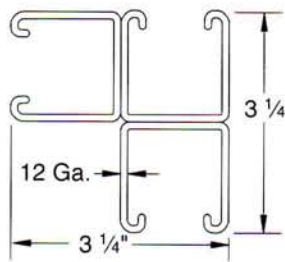
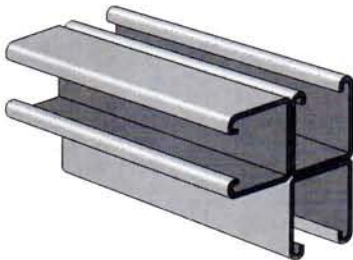

Modulus of Elasticity: 29,000,000 PSI

**ELEMENTS OF SECTION**

Part No.	Weight (lbs./100 ft.)	Area of Section (Inch <sup>2</sup> )	X-X Axis			Y-Y Axis		
			Moment of Inertia (Inch <sup>4</sup> )	Section Modulus (Inch <sup>3</sup> )	Radius of Gyration (Inch)	Moment of Inertia (Inch <sup>4</sup> )	Section Modulus (Inch <sup>3</sup> )	Radius of Gyration (Inch)
PS 200 2T2	380	1.112	1.206	.742	1.042	.382	.470	.586
PS 200 2T4	380	1.112	1.065	.635	.979	.424	.491	.617
PS 200 2T5	380	1.112	1.206	.742	1.042	.370	.404	.577
PS 200 3T6	570	1.667	1.410	.744	.920	1.515	.785	.953

# CHANNEL



## General Information

Column loads are for allowable axial loads and must be reduced for eccentric loading. For concentrated load at center of span, divide uniform load by 2 and multiply corresponding deflection by 0.8.

Dynamic loads should be used for design when the channel is used for support of plumbing, heating, process or power piping.



## PS 200 – BEAM & COLUMN LOADS

Part No.	Span, or Column Inches	Column Load	Dynamic Beam Load X-X Axis	Static Beam Load X-X Axis		
		Maximum Load Lbs.	Uniform Load Lbs. @ 12,000 PSI Stress	Uniform Load Lbs. @25,000 PSI Stress	Deflection Inches @25,000 PSI Stress	Uniform Load Lbs @ 1/240 Span Deflection
PS 200 2T2	12	23,960	3,560 *	3,560 *	0.01	-
PS 200 2T4		23,990	3,350 *	3,350 *	0.01	-
PS 200 2T5		23,950	3,560 *	3,560 *	0.01	-
PS 200 3T6		36,240	4,740 *	4,740 *	0.01	-
PS 200 2T2	18	23,500	3,560 *	3,560 *	0.01	-
PS 200 2T4		23,580	3,350 *	3,350 *	0.01	-
PS 200 2T5		23,470	3,560 *	3,560 *	0.01	-
PS 200 3T6		35,960	3,990	4,740 *	0.01	-
PS 200 2T2	24	22,850	2,990	3,560 *	0.02	-
PS 200 2T4		23,000	2,560	3,350 *	0.02	-
PS 200 2T5		22,810	2,990	3,560 *	0.02	-
PS 200 3T6		35,570	2,990	4,740 *	0.02	-
PS 200 2T2	30	22,030	2,390	3,560 *	0.04	-
PS 200 2T4		22,250	2,040	3,350 *	0.04	-
PS 200 2T5		21,950	2,390	3,560 *	0.04	-
PS 200 3T6		35,070	2,390	4,740 *	0.04	-
PS 200 2T2	36	21,010	1,990	3,560 *	0.06	-
PS 200 2T4		21,340	1,700	3,350 *	0.07	-
PS 200 2T5		20,910	1,990	3,560 *	0.06	-
PS 200 3T6		34,450	2,000	4,160	0.06	-
PS 200 2T2	42	19,820	1,710	3,550	0.10	-
PS 200 2T4		20,260	1,460	3,040	0.10	-
PS 200 2T5		19,680	1,710	3,550	0.10	-
PS 200 3T6		33,720	1,710	3,560	0.09	-
PS 200 2T2	48	18,440	1,490	3,110	0.13	-
PS 200 2T4		19,020	1,280	2,660	0.12	-
PS 200 2T5		18,250	1,490	3,110	0.13	-
PS 200 3T6		32,890	1,500	3,120	0.11	-
PS 200 2T2	54	16,880	1,330	2,760	0.16	-
PS 200 2T4		17,610	1,140	2,370	0.16	-
PS 200 2T5		16,640	1,330	2,760	0.16	-
PS 200 3T6		31,930	1,330	2,770	0.14	-

\*Load limited by spot weld shear.



## General Information

Column loads are for allowable axial loads and must be reduced for eccentric loading. For concentrated load at center of span, divide uniform load by 2 and multiply corresponding deflection by 0.8. Dynamic loads should be used for design when the channel is used for support of plumbing, heating, process or power piping.



## PS 200 – BEAM &amp; COLUMN LOADS (CONTINUED)

Part No.	Span, or Column Inches	Column Load	Dynamic Beam Load X-X Axis	Static Beam Load X-X Axis		
		Maximum Load Lbs.	Uniform Load Lbs. @ 12,000 PSI Stress	Uniform Load Lbs. @25,000 PSI Stress	Deflection Inches @25,000 PSI Stress	Uniform Load Lbs @ 1/240 Span Deflection
PS 200 2T2	60	15,130	1,190	2,490	0.20	–
PS 200 2T4		16,030	1,020	2,130	0.19	–
PS 200 2T5		14,840	1,190	2,490	0.20	–
PS 200 3T6		30,870	1,200	2,490	0.17	–
PS 200 2T2	66	13,200	1,090	2,260	0.24	–
PS 200 2T4		14,290	930	1,940	0.23	–
PS 200 2T5		12,850	1,090	2,260	0.24	–
PS 200 3T6		29,700	1,090	2,270	0.21	–
PS 200 2T2	72	11,170	1,000	2,070	0.29	–
PS 200 2T4		12,380	850	1,770	0.28	–
PS 200 2T5		10,830	1,000	2,070	0.29	–
PS 200 3T6		28,410	1,000	2,080	0.25	–
PS 200 2T2	84	8,210	850	1,780	0.39	1,610
PS 200 2T4		9,100	730	1,520	0.38	1,420
PS 200 2T5		7,960	850	1,780	0.39	1,610
PS 200 3T6		25,500	860	1,780	0.33	–
PS 200 2T2	96	6,280	750	1,560	0.51	1,240
PS 200 2T4		6,970	640	1,330	0.49	1,090
PS 200 2T5		6,090	750	1,560	0.51	1,240
PS 200 3T6		22,150	750	1,560	0.44	1,440
PS 200 2T2	108	4,960	660	1,380	0.64	980
PS 200 2T4		5,500	570	1,180	0.62	860
PS 200 2T5		4,810	660	1,380	0.64	980
PS 200 3T6		18,340	670	1,390	0.55	1,140
PS 200 2T2	120	–	600	1,240	0.79	790
PS 200 2T4		4,460	510	1,060	0.76	700
PS 200 2T5		–	600	1,240	0.79	790
PS 200 3T6		14,860	600	1,250	0.68	920

# CHANNEL

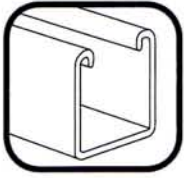

**General Information**  
 Finish: Plain, painted green or pre-galvanized  
 Stock Length: 10' and 20', other lengths on request  
 Order By: Part No., Length & Finish



## PS 200 PLA – Welded Steel Channel and Plate

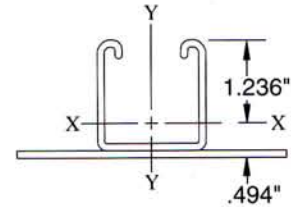
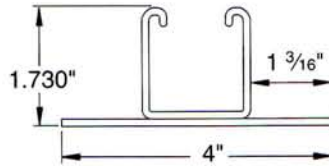
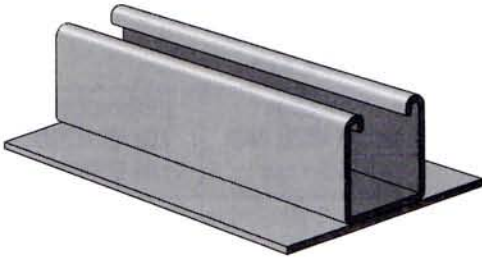

## PS 200 PLB – Welded Steel Channel and Plate

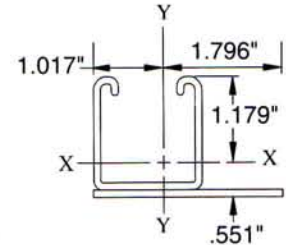
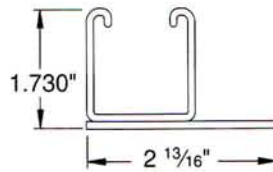
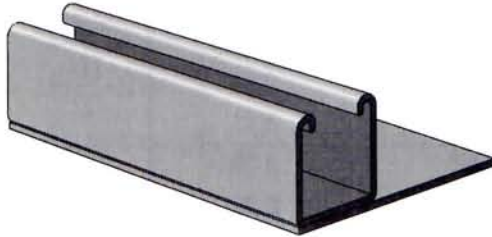

## PS 200 PLC – Welded Steel Channel and Plate

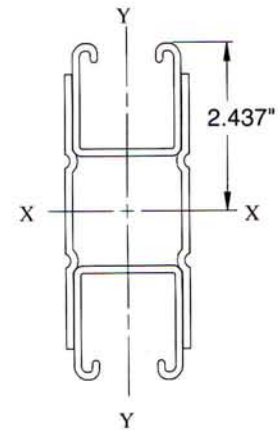
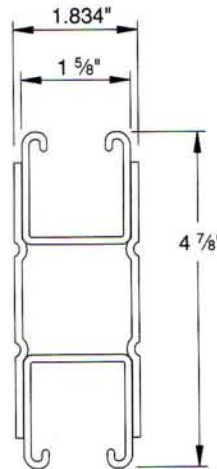

Modulus of Elasticity: 29,000,000 PSI

### ELEMENTS OF SECTION

Part No.	Weight (lbs./100 ft.)	Area of Section (Inch <sup>2</sup> )	X-X Axis			Y-Y Axis		
			Moment of Inertia (Inch <sup>4</sup> )	Section Modulus (Inch <sup>3</sup> )	Radius of Gyration (Inch)	Moment of Inertia (Inch <sup>4</sup> )	Section Modulus (Inch <sup>3</sup> )	Radius of Gyration (Inch)
PS 200 PLA	332	.976	.324	.261	.577	.796	.398	.903
PS 200 PLB	291	.851	.293	.249	.587	.495	.276	.763
PS 200 PLC	670	1.978	4.079	1.673	1.436	1.121	1.204	.753



**General Information**

Column loads are for allowable axial loads and must be reduced for eccentric loading. For concentrated load at center of span, divide uniform load by 2 and multiply corresponding deflection by 0.8. Dynamic loads should be used for design when the channel is used for support of plumbing, heating, process or power piping.



**PS 200 PLA, PS 200 PLB, PS 200 PLC – BEAM & COLUMN LOADS**

Part No.	Span, or Column Inches	Column Load	Dynamic Beam Load X-X Axis	Static Beam Load X-X Axis		
		Maximum Load Lbs.	Uniform Load Lbs. @ 12,000 PSI Stress	Uniform Load Lbs. @25,000 PSI Stress	Deflection Inches @25,000 PSI Stress	Uniform Load Lbs @ 1/240 Span Deflection
PS 200 PL A	12	13,140	1,900 *	1,900 *	0.01	-
PS 200 PL B		12,980	1,700 *	1,700 *	0.01	-
PS 200 PL C		42,880	9,350 *†	9,350 *†	0.00	-
PS 200 PL A	18	12,680	1,400	1,900 *	0.02	-
PS 200 PL B		12,400	1,340	1,700 *	0.02	-
PS 200 PL C		42,380	8,980	9,350 *†	0.01	-
PS 200 PL A	24	12,210	1,050	1,900 *	0.04	-
PS 200 PL B		11,850	1,000	1,700 *	0.04	-
PS 200 PL C		41,680	6,730	9,350 *†	0.02	-
PS 200 PL A	30	11,570	840	1,750	0.07	-
PS 200 PL B		11,330	800	1,670	0.07	-
PS 200 PL C		40,870	5,390	9,350 *†	0.03	-
PS 200 PL A	36	10,870	700	1,460	0.10	-
PS 200 PL B		10,820	670	1,390	0.10	-
PS 200 PL C		39,700	4,490	9,350 *†	0.05	-
PS 200 PL A	42	10,110	600	1,250	0.13	-
PS 200 PL B		10,040	570	1,190	0.14	-
PS 200 PL C		38,490	3,850	8,020 †	0.07	-
PS 200 PL A	48	9,280	520	1,090	0.17	-
PS 200 PL B		9,200	500	1,040	0.18	-
PS 200 PL C		36,930	3,370	7,010	0.09	-
PS 200 PL A	54	8,400	470	970	0.21	-
PS 200 PL B		8,300	450	930	0.22	-
PS 200 PL C		35,300	2,990	6,230	0.11	-
PS 200 PL A	60	7,450	420	870	0.26	850
PS 200 PL B		7,330	400	830	0.27	770
PS 200 PL C		33,360	2,690	5,610	0.13	-
PS 200 PL A	66	6,440	380	800	0.32	700
PS 200 PL B		6,290	360	760	0.33	630
PS 200 PL C		31,320	2,450	5,100	0.16	-
PS 200 PL A	72	5,410	350	730	0.37	590
PS 200 PL B		5,280	330	700	0.40	530
PS 200 PL C		29,000	2,240	4,680	0.19	-
PS 200 PL A	84	3,980	300	620	0.50	430
PS 200 PL B		3,880	290	600	0.54	-
PS 200 PL C		23,850	1,920	4,010	0.26	-
PS 200 PL A	96	3,050	260	550	0.67	330
PS 200 PL B		2,970	250	520	0.70	300
PS 200 PL C		18,450	1,680	3,510	0.34	-
PS 200 PL A	108	2,410	230	490	0.84	260
PS 200 PL B		2,350	220	460	0.88	240
PS 200 PL C		14,580	1,500	3,120	0.43	-
PS 200 PL A	120	-	210	440	1.04	210
PS 200 PL B		-	200	420	1.10	190
PS 200 PL C		11,810	1,350	2,810	0.53	2,670

\*Load limited by spot weld shear. †Bearing load may govern capacity.

# CHANNEL

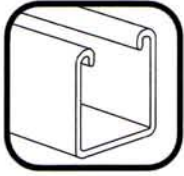

**General Information**  
 Finish: Plain, painted green or pre-galvanized  
 Stock Length: 10' and 20', other lengths on request  
 Order By: Part No., Length & Finish



## PS 210 – Steel Channel (1 5/8" x 1 5/8" x 14 ga.)

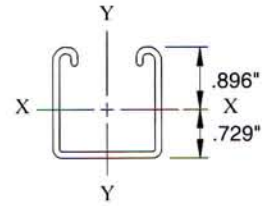
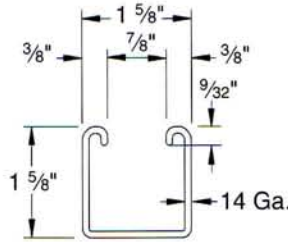
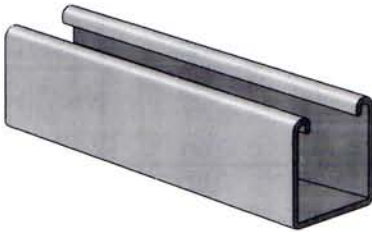

### ELEMENTS OF SECTION

Weight (lbs./100 ft.)	Area of Section (Inch <sup>2</sup> )	X-X Axis			Y-Y Axis		
		Moment of Inertia (Inch <sup>4</sup> )	Section Modulus (Inch <sup>3</sup> )	Radius of Gyration (Inch)	Moment of Inertia (Inch <sup>4</sup> )	Section Modulus (Inch <sup>3</sup> )	Radius of Gyration (Inch)
141	.417	.149	.166	.597	.183	.225	.662

Modulus of Elasticity: 29,000,000 PSI

### PS 210 H – Channel with Holes

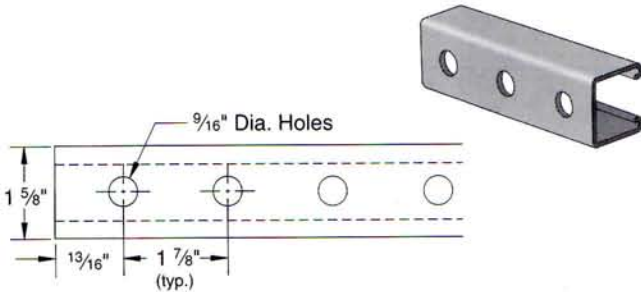

Weight: 137 lbs./100 ft.

### PS 210 EH – Channel with Elongated Holes

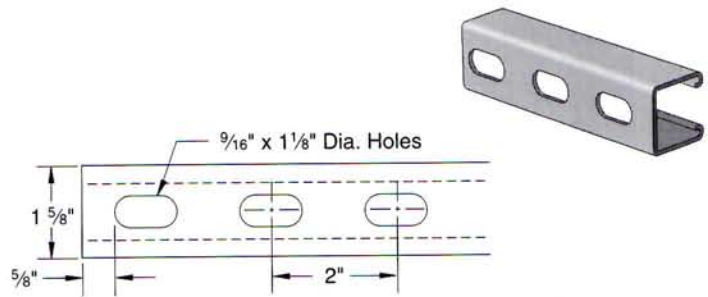

Weight: 137 lbs./100 ft.

### PS 210 S – Channel with Slots

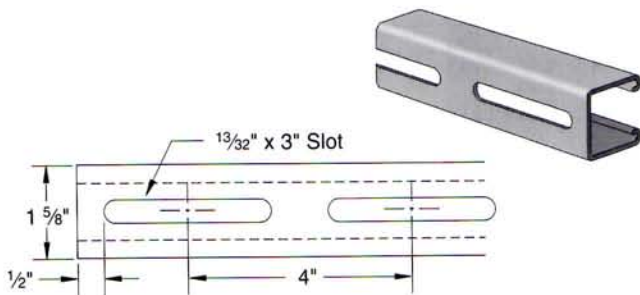

Weight: 137 lbs./100 ft.

### PS 210 K06 – Channel with Knockouts

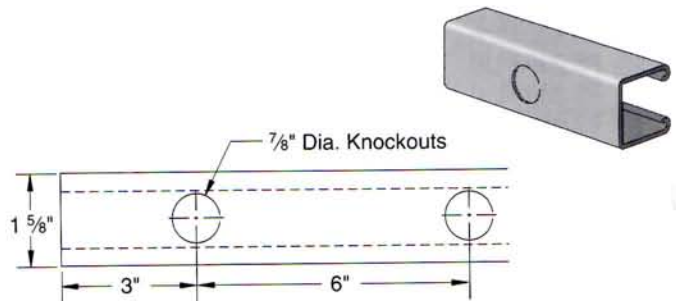

Weight: 141 lbs./100 ft.





General Information  
 Finish: Plain, painted green or pre-galvanized  
 Stock Length: 10' and 20', other lengths on request  
 Order By: Part No., Length & Finish

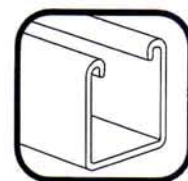

**PS 210 – BEAM & COLUMN LOADS**

Span, or Column Inches	Column Load	Dynamic Beam Load X-X Axis	Static Beam Load X-X Axis		
	Maximum Load Lbs.	Uniform Load Lbs. @ 12,000 PSI Stress	Uniform Load Lbs. @25,000 PSI Stress	Deflection Inches @25,000 PSI Stress	Uniform Lbs @ 1/240 Span Deflection
12	7,940	1,330	2,780	0.01	–
18	7,510	890	1,850	0.03	–
24	6,960	670	1,390	0.06	–
30	5,930	530	1,110	0.09	–
36	4,900	440	930	0.13	–
42	4,070	380	790	0.17	–
48	3,250	330	700	0.23	610
54	2,840	300	620	0.29	480
60	2,430	270	560	0.36	390
66	2,190	240	510	0.43	320
72	1,950	220	460	0.51	270
84	1,640	190	400	0.70	200
96	1,400	170	350	0.91	150
108	1,220	150	310	1.15	120
120	–	130	280	1.42	100

For Pierced Channels, reduce beam load values as follows:

- PS-210-EH 15%
- PS-210-S 15%
- PS-210-H 10%
- PS-210-K06 5%

Column loads are for allowable axial loads and must be reduced for eccentric loading. For concentrated load at center of span, divide uniform load by 2 and multiply corresponding deflection by 0.8. Dynamic loads should be used for design when the channel is used for support of plumbing, heating, process or power piping. This load table is based on a solid channel section.

**PS 210 – CRUSH LOADS**

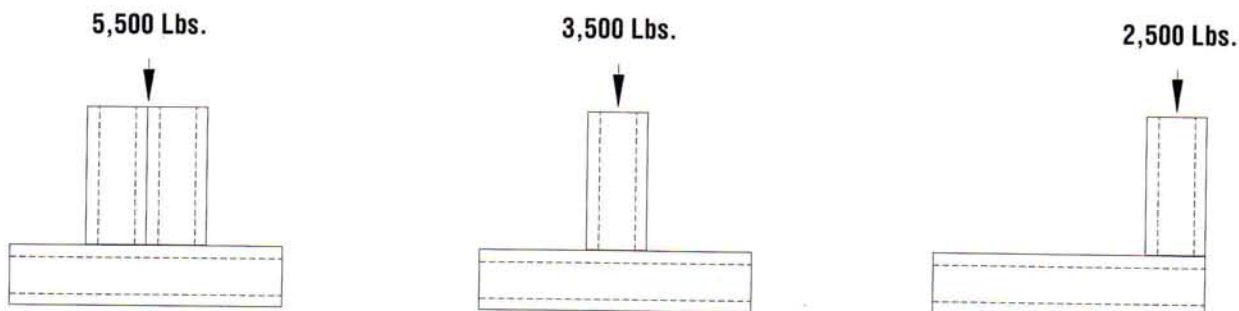

**Resistance to Slip:** 1,000 lbs. per bolt when 1/2" PS NS channel nuts are used.  
**Pull Out Strength:** 1,400 lbs. per bolt when 1/2" PS NS channel nuts are used.

# CHANNEL



**General Information**  
 Finish: Plain, painted green or pre-galvanized  
 Stock Length: 10' and 20', other lengths on request  
 Order By: Part No., Length & Finish



## PS 210 2T3 – Steel Channel (1 5/8" x 3 1/4" x 14 ga.)

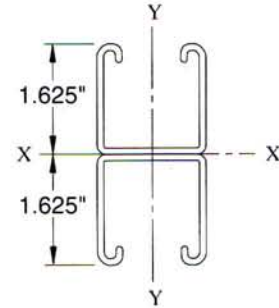
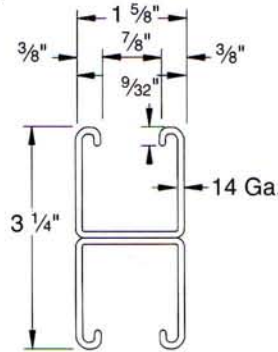
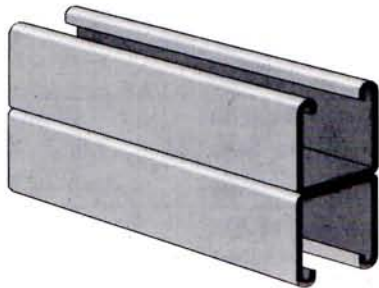

### ELEMENTS OF SECTION

Weight (lbs./100 ft.)	Area of Section (Inch <sup>2</sup> )	X-X Axis			Y-Y Axis		
		Moment of Inertia (Inch <sup>4</sup> )	Section Modulus (Inch <sup>3</sup> )	Radius of Gyration (Inch)	Moment of Inertia (Inch <sup>4</sup> )	Section Modulus (Inch <sup>3</sup> )	Radius of Gyration (Inch)
282	.834	.741	.456	.942	.366	.451	.662

Modulus of Elasticity: 29,000,000 PSI

### BEAM & COLUMN LOADS

Span, or Column Inches	Column Load	Dynamic Beam Load X-X Axis	Static Beam Load X-X Axis		
	Maximum Load Lbs.	Uniform Load Lbs. @ 12,000 PSI Stress	Uniform Load Lbs. @25,000 PSI Stress	Deflection Inches @25,000 PSI Stress	Uniform Load Lbs @ 1/240 Span Deflection
12	17,780	1,850 *	1,850 *	0.00	–
18	17,610	1,850 *	1,850 *	0.01	–
24	17,380	1,840	1,850 *	0.02	–
30	16,840	1,470	1,850 *	0.03	–
36	16,300	1,220	1,850 *	0.05	–
42	15,540	1,050	1,850 *	0.08	–
48	14,780	920	1,850 *	0.12	–
54	13,810	820	1,700	0.16	–
60	12,840	730	1,530	0.20	–
66	11,650	670	1,390	0.24	–
72	10,460	610	1,270	0.29	–
84	7,850	520	1,090	0.39	990
96	6,010	460	960	0.51	760
108	4,750	410	850	0.64	600
120	3,850	370	760	0.79	490

\*Load limited by spot weld shear.



**General Information**

Finish: Plain, painted green or pre-galvanized  
 Stock Length: 10' and 20', other lengths on request  
 Order By: Part No., Length & Finish



**PS 300 – Steel Channel (1 5/8" x 1 3/8" x 12 ga.)**

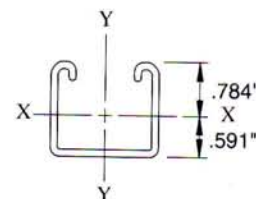
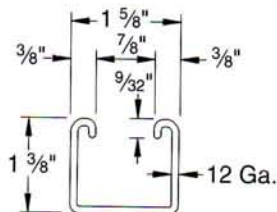
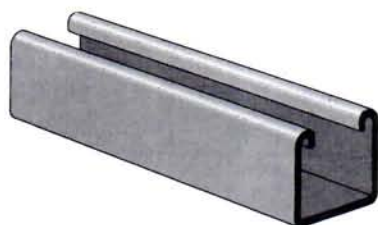

**ELEMENTS OF SECTION**

Weight (lbs./100 ft.)	Area of Section (Inch <sup>2</sup> )	X-X Axis			Y-Y Axis		
		Moment of Inertia (Inch <sup>4</sup> )	Section Modulus (Inch <sup>3</sup> )	Radius of Gyration (Inch)	Moment of Inertia (Inch <sup>4</sup> )	Section Modulus (Inch <sup>3</sup> )	Radius of Gyration (Inch)
170	.503	.121	.154	.490	.205	.253	.639

Modulus of Elasticity: 29,000,000 PSI

**PS 300 H – Channel with Holes**

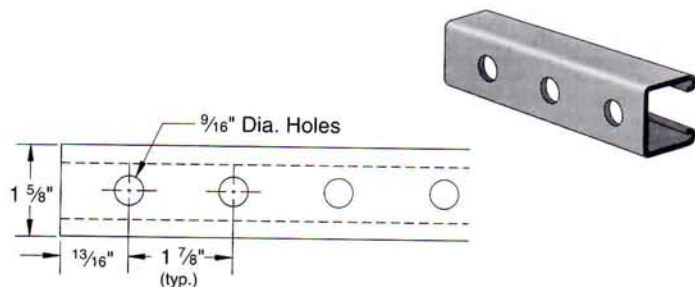

Weight: 165 lbs./100 ft.

**PS 300 EH – Channel with Elongated Holes**

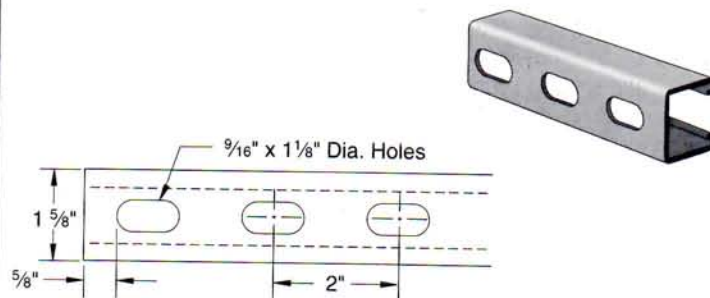

Weight: 165 lbs./100 ft.

**PS 300 S – Channel with Slots**

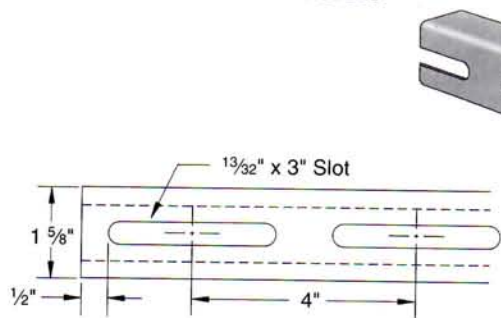

Weight: 165 lbs./100 ft.

**PS 300 K06 – Channel with Knockouts**

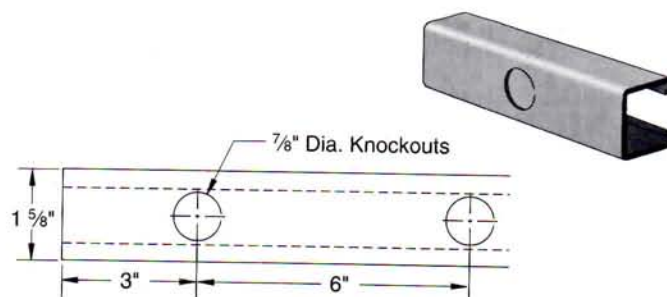

Weight: 170 lbs./100 ft.

# CHANNEL



**General Information**  
 Finish: Plain, painted green or pre-galvanized  
 Stock Length: 10' and 20', other lengths on request  
 Order By: Part No., Length & Finish



## PS 300 – BEAM & COLUMN LOADS

Span, or Column Inches	Column Load	Dynamic Beam Load X-X Axis	Static Beam Load X-X Axis		
	Maximum Load Lbs.	Uniform Load Lbs. @ 12,000 PSI Stress	Uniform Load Lbs. @25,000 PSI Stress	Deflection Inches @25,000 PSI Stress	Uniform Load Lbs @ 1/240 Span Deflection
12	10,320	1,240	2,580	0.02	–
18	9,530	830	1,720	0.04	–
24	8,640	620	1,290	0.07	–
30	7,780	500	1,030	0.10	–
36	6,930	410	860	0.15	–
42	6,120	350	740	0.20	650
48	5,310	310	650	0.26	500
54	4,720	280	570	0.33	390
60	4,130	250	520	0.41	320
66	3,730	230	470	0.49	260
72	3,340	210	430	0.59	220
84	2,600	180	370	0.80	160
96	1,990	150	320	1.04	120
108	–	140	290	1.32	100
120	–	120	260	1.63	80

For Pierced Channels, reduce beam load values as follows:

- PS-300-EH 15%
- PS-300-S 15%
- PS-300-H 10%
- PS-300-K06 5%

Column loads are for allowable axial loads and must be reduced for eccentric loading. For concentrated load at center of span, divide uniform load by 2 and multiply corresponding deflection by 0.8. Dynamic loads should be used for design when the channel is used for support of plumbing, heating, process or power piping. This load table is based on a solid channel section.

## PS 300 – CRUSH LOADS

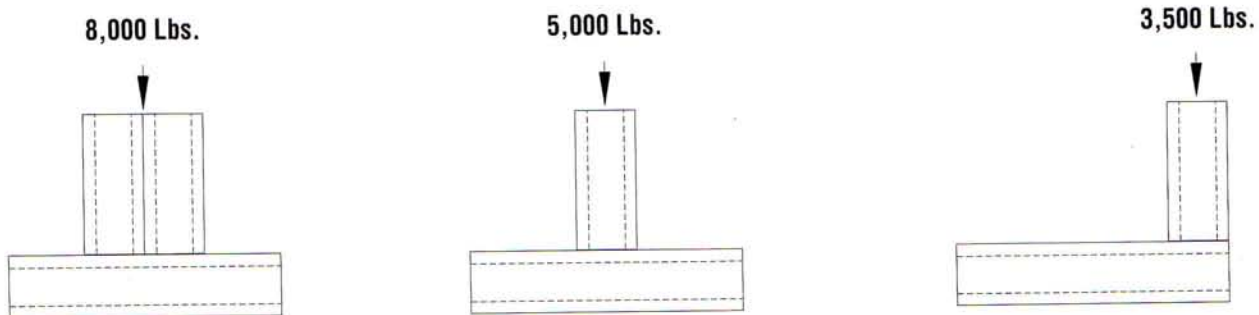

**Resistance to Slip:** 1,500 lbs. per bolt when 1/2" PS NS channel nuts are used.  
**Pull Out Strength:** 2,000 lbs. per bolt when 1/2" PS NS channel nuts are used.



General Information  
 Finish: Plain, painted green or pre-galvanized  
 Stock Length: 10' and 20', other lengths on request  
 Order By: Part No., Length & Finish

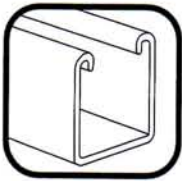

**PS 300 2T3 – Steel Channel (1 5/8" x 2 3/4" x 12 ga.)**

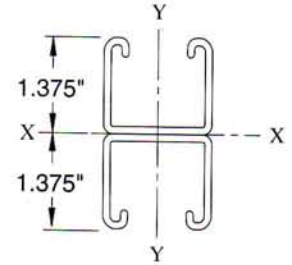
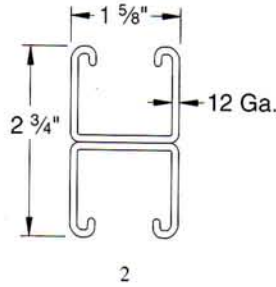
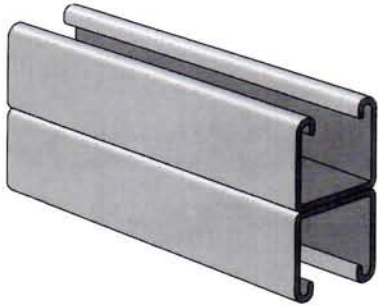

**ELEMENTS OF SECTION**

Weight (lbs./100 ft.)	Area of Section (Inch <sup>2</sup> )	X-X Axis			Y-Y Axis		
		Moment of Inertia (Inch <sup>4</sup> )	Section Modulus (Inch <sup>3</sup> )	Radius of Gyration (Inch)	Moment of Inertia (Inch <sup>4</sup> )	Section Modulus (Inch <sup>3</sup> )	Radius of Gyration (Inch)
340	1.007	.593	.431	.767	.411	.506	.639

Modulus of Elasticity: 29,000,000 PSI

**BEAM & COLUMN LOADS**

Span, or Column Inches	Column Load	Dynamic Beam Load X-X Axis	Static Beam Load X-X Axis		
	Maximum Load Lbs.	Uniform Load Lbs. @ 12,000 PSI Stress	Uniform Load Lbs. @25,000 PSI Stress	Deflection Inches @25,000 PSI Stress	Uniform Load Lbs @ 1/240 Span Deflection
12	21,750	2,660 *	2,660 *	0.01	-
18	21,400	2,310	2,660 *	0.01	-
24	20,910	1,730	2,660 *	0.03	-
30	20,280	1,390	2,660 *	0.06	-
36	19,510	1,160	2,410	0.09	-
42	18,600	990	2,060	0.12	-
48	17,550	870	1,810	0.15	-
54	16,350	770	1,610	0.19	-
60	15,020	690	1,450	0.24	-
66	13,550	630	1,310	0.28	1,290
72	11,940	580	1,200	0.34	1,080
84	8,840	500	1,030	0.46	790
96	6,770	430	900	0.60	610
108	5,350	390	800	0.75	480
120	4,330	350	720	0.93	390

\*Load limited by spot weld shear.

# CHANNEL

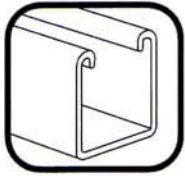

**General Information**  
 Finish: Plain, painted green or pre-galvanized  
 Stock Length: 10' and 20', other lengths on request  
 Order By: Part No., Length & Finish



## PS 400 – Steel Channel (1 5/8" x 1" x 12 ga.)

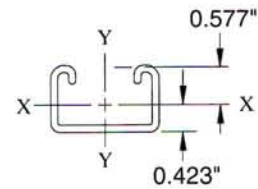
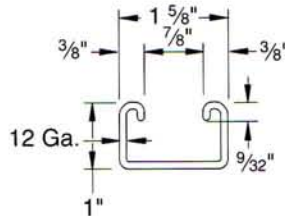

### ELEMENTS OF SECTION

Weight (lbs./100 ft.)	Area of Section (Inch <sup>2</sup> )	X-X Axis			Y-Y Axis		
		Moment of Inertia (Inch <sup>4</sup> )	Section Modulus (Inch <sup>3</sup> )	Radius of Gyration (Inch)	Moment of Inertia (Inch <sup>4</sup> )	Section Modulus (Inch <sup>3</sup> )	Radius of Gyration (Inch)
146	0.430	0.055	0.095	0.357	0.163	0.201	0.616

Modulus of Elasticity: 29,000,000 PSI

### PS 400 H – Channel with Holes

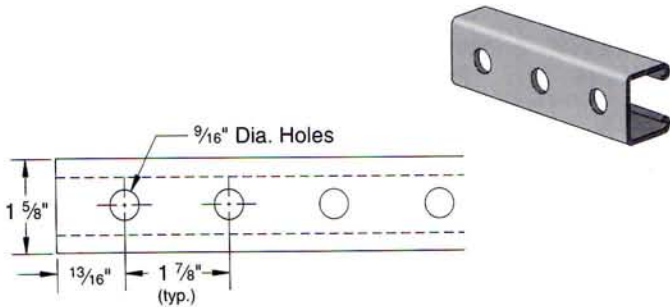

Weight: 141 lbs./100 ft.

### PS 400 EH – Channel with Elongated Holes

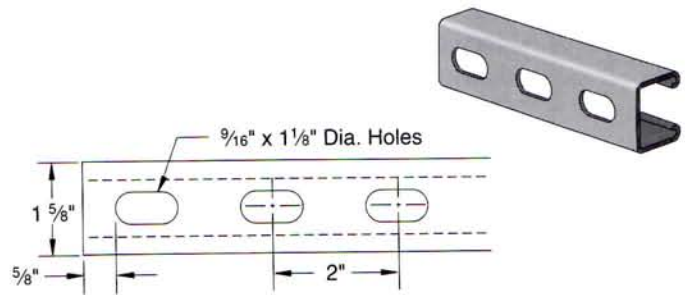

Weight: 141 lbs./100 ft.

### PS 400 S – Channel with Slots

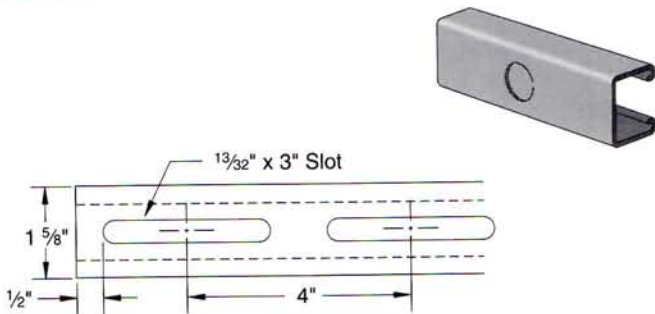

Weight: 141 lbs./100 ft.

### PS 400 K06 – Channel with Knockouts

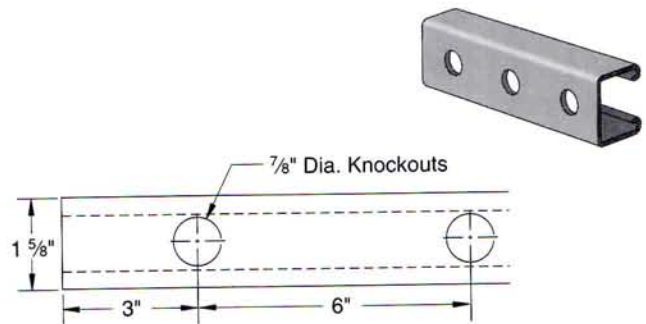

Weight: 146 lbs./100 ft.



General Information  
 Finish: Plain, painted green or pre-galvanized  
 Stock Length: 10' and 20', other lengths on request  
 Order By: Part No., Length & Finish



**PS 400 – BEAM & COLUMN LOADS**

Span, or Column Inches	Column Load	Dynamic Beam Load X-X Axis	Static Beam Load X-X Axis		
	Maximum Load Lbs.	Uniform Load Lbs. @ 12,000 PSI Stress	Uniform Load Lbs. @25,000 PSI Stress	Deflection Inches @25,000 PSI Stress	Uniform Lbs @ 1/240 Span Deflection
12	9,020	760	1,590	0.02	–
18	8,540	510	1,060	0.05	–
24	7,870	380	800	0.09	–
30	7,010	310	640	0.14	580
36	5,960	250	530	0.20	400
42	4,710	220	460	0.27	290
48	3,610	190	400	0.35	230
54	2,850	170	350	0.45	180
60	2,310	150	320	0.55	140
66	1,910	140	290	0.67	120
72	–	130	270	0.80	100
84	–	110	230	1.08	70
96	–	100	200	1.41	60
108	–	80	180	1.79	40
120	–	80	160	2.21	40

For Pierced Channels, reduce beam load values as follows:

- PS-400-EH 15%
- PS-400-S 15%
- PS-400-H 10%
- PS-400-K06 5%

Column loads are for allowable axial loads and must be reduced for eccentric loading. For concentrated load at center of span, divide uniform load by 2 and multiply corresponding deflection by 0.8. Dynamic loads should be used for design when the channel is used for support of plumbing, heating, process or power piping. This load table is based on a solid channel section.

**PS 400 – CRUSH LOADS**

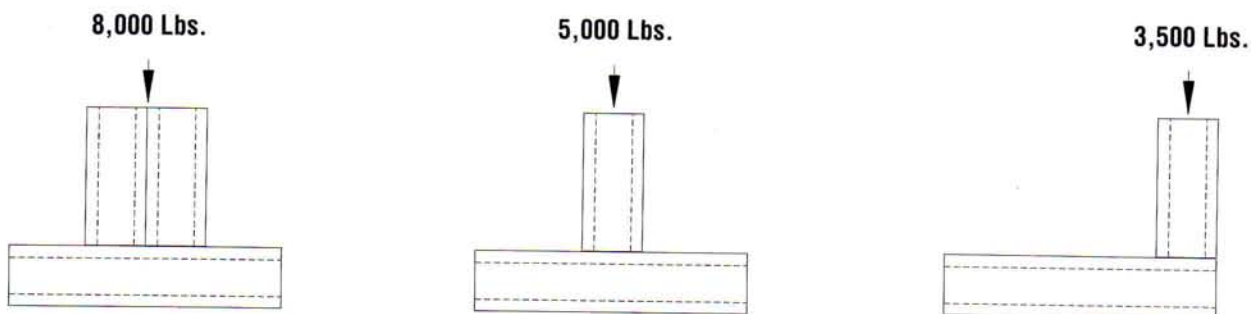

**Resistance to Slip:** 1,500 lbs. per bolt when 1/2" PS NS channel nuts are used.  
**Pull Out Strength:** 2,000 lbs. per bolt when 1/2" PS NS channel nuts are used.

# CHANNEL



**General Information**  
 Finish: Plain, painted green or pre-galvanized  
 Stock Length: 10' and 20', other lengths on request  
 Order By: Part No., Length & Finish



## PS 400 2T3 – Steel Channel (1 5/8" x 2" x 12 ga.)

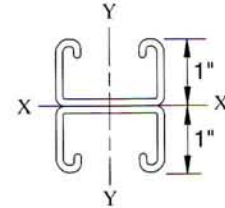
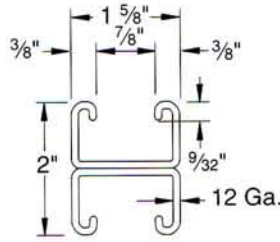

### ELEMENTS OF SECTION

Weight (lbs./100 ft.)	Area of Section (Inch <sup>2</sup> )	X-X Axis			Y-Y Axis		
		Moment of Inertia (Inch <sup>4</sup> )	Section Modulus (Inch <sup>3</sup> )	Radius of Gyration (Inch)	Moment of Inertia (Inch <sup>4</sup> )	Section Modulus (Inch <sup>3</sup> )	Radius of Gyration (Inch)
292	0.860	0.263	0.263	0.553	0.327	0.402	0.616

Modulus of Elasticity: 29,000,000 PSI

### BEAM & COLUMN LOADS

Span, or Column Inches	Column Load	Dynamic Beam Load X-X Axis	Static Beam Load X-X Axis		
	Maximum Load Lbs.	Uniform Load Lbs. @ 12,000 PSI Stress	Uniform Load Lbs. @25,000 PSI Stress	Deflection Inches @25,000 PSI Stress	Uniform Lbs @ 1/240 Span Deflection
12	18,490	1,920 *	1,920 *	0.01	–
18	18,090	1,410	1,920 *	0.02	–
24	17,530	1,060	1,920 *	0.05	–
30	16,820	850	1,760	0.08	–
36	15,940	710	1,470	0.12	–
42	14,900	600	1,260	0.16	–
48	13,700	530	1,100	0.21	1,080
54	12,340	470	980	0.26	850
60	10,830	420	880	0.32	690
66	9,160	380	800	0.39	570
72	7,690	350	730	0.46	480
84	5,650	300	630	0.63	350
96	4,330	260	550	0.82	270
108	3,420	240	490	1.04	210
120	–	210	440	1.28	170

\*Load limited by spot weld shear.





**General Information**  
 Finish: Plain, painted green or pre-galvanized  
 Stock Length: 10' and 20', other lengths on request  
 Order By: Part No., Length & Finish

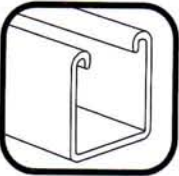

**PS 500** – Steel Channel (1 5/8" x 13/16" x 14 ga.)

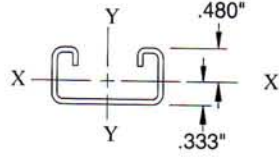
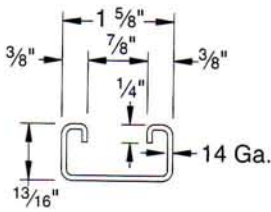
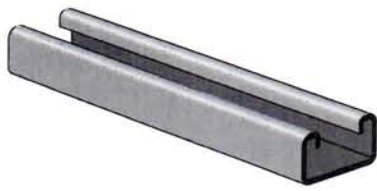

**ELEMENTS OF SECTION**

Weight (lbs./100 ft.)	Area of Section (Inch <sup>2</sup> )	X-X Axis			Y-Y Axis		
		Moment of Inertia (Inch <sup>4</sup> )	Section Modulus (Inch <sup>3</sup> )	Radius of Gyration (Inch)	Moment of Inertia (Inch <sup>4</sup> )	Section Modulus (Inch <sup>3</sup> )	Radius of Gyration (Inch)
97	0.287	0.025	0.053	0.298	0.106	0.131	0.609

Modulus of Elasticity: 29,000,000 PSI

**PS 500 H** – Channel with Holes

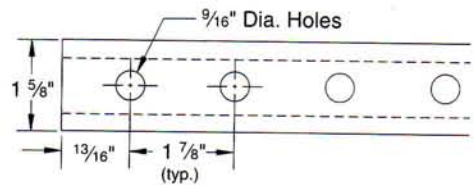

Weight: 87 lbs./100 ft.

**PS 500 EH** – Channel with Elongated Holes

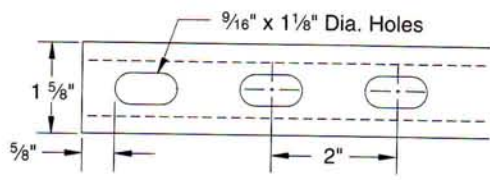
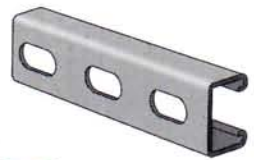

Weight: 87 lbs./100 ft.

**PS 500 S** – Channel with Slots

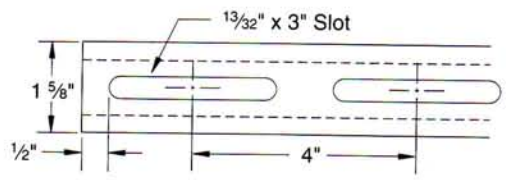
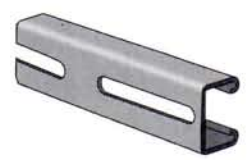

Weight: 87 lbs./100 ft.

# CHANNEL



General Information  
 Finish: Plain, painted green or pre-galvanized  
 Stock Length: 10' and 20', other lengths on request  
 Order By: Part No., Length & Finish



## PS 500 – BEAM & COLUMN LOADS

Span, or Column Inches	Column Load	Dynamic Beam Load X-X Axis	Static Beam Load X-X Axis		
	Maximum Load Lbs.	Uniform Load Lbs. @ 12,000 PSI Stress	Uniform Load Lbs. @25,000 PSI Stress	Deflection Inches @25,000 PSI Stress	Uniform Load Lbs @ 1/240 Span Deflection
12	5,910	430	890	0.03	–
18	5,450	280	590	0.06	–
24	4,810	210	440	0.11	410
30	3,980	170	350	0.17	260
36	2,980	140	300	0.24	180
42	2,190	120	250	0.33	130
48	1,680	110	220	0.43	100
54	1,330	90	200	0.55	80
60	–	90	180	0.68	70
66	–	80	160	0.82	50
72	–	70	150	0.97	50
84	–	60	130	1.33	30
96	–	50	110	1.73	30
108	–	50	100	2.19	20
120	–	40	90	2.71	20

For Pierced Channels, reduce beam load values as follows:

- PS-500-EH 15%
- PS-500-S 15%
- PS-500-H 10%

Column loads are for allowable axial loads and must be reduced for eccentric loading. For concentrated load at center of span, divide uniform load by 2 and multiply corresponding deflection by 0.8. Dynamic loads should be used for design when the channel is used for support of plumbing, heating, process or power piping. This load table is based on a solid channel section.

## PS 500 – CRUSH LOADS

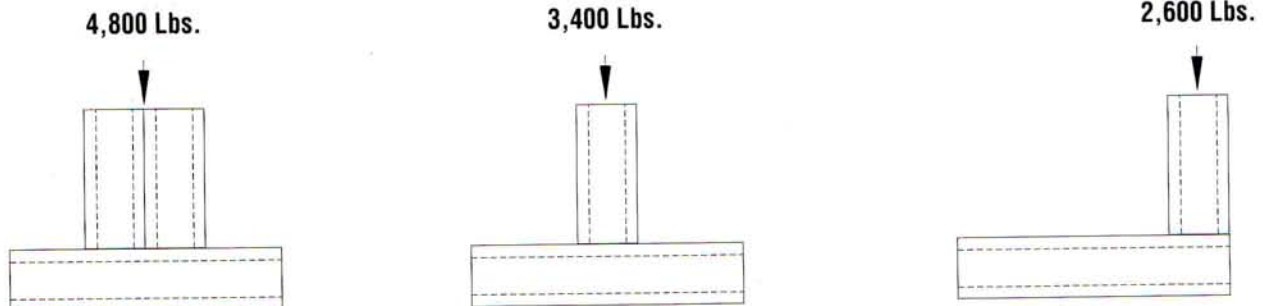

**Resistance to Slip:** 1,000 lbs. per bolt when 1/2" PS NS channel nuts are used.  
**Pull Out Strength:** 1,400 lbs. per bolt when 1/2" PS NS channel nuts are used.



General Information  
 Finish: Plain, painted green or pre-galvanized  
 Stock Length: 10' and 20', other lengths on request  
 Order By: Part No., Length & Finish



**PS 500 2T3** – Steel Channel (1 5/8" x 1 5/8" x 14 ga.)

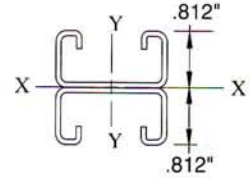
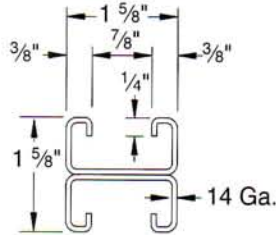
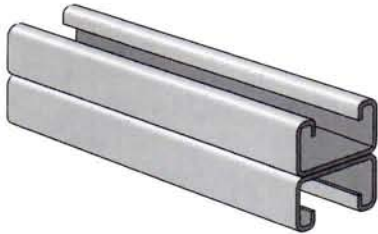

**ELEMENTS OF SECTION**

Weight (lbs./100 ft.)	Area of Section (Inch <sup>2</sup> )	X-X Axis			Y-Y Axis		
		Moment of Inertia (Inch <sup>4</sup> )	Section Modulus (Inch <sup>3</sup> )	Radius of Gyration (Inch)	Moment of Inertia (Inch <sup>4</sup> )	Section Modulus (Inch <sup>3</sup> )	Radius of Gyration (Inch)
194	0.574	0.114	0.141	0.447	0.212	0.261	0.609

Modulus of Elasticity: 29,000,000 PSI

**BEAM & COLUMN LOADS**

Span, or Column Inches	Column Load	Dynamic Beam Load X-X Axis	Static Beam Load X-X Axis		
	Maximum Load Lbs.	Uniform Load Lbs. @ 12,000 PSI Stress	Uniform Load Lbs. @25,000 PSI Stress	Deflection Inches @25,000 PSI Stress	Uniform Load Lbs @ 1/240 Span Deflection
12	12,230	910 *	910 *	0.01	–
18	11,820	760	910 *	0.02	–
24	11,250	570	910 *	0.05	–
30	10,520	450	910 *	0.10	–
36	9,620	380	790	0.15	–
42	8,560	320	680	0.20	610
48	7,330	280	590	0.26	470
54	5,960	250	530	0.33	370
60	4,830	230	470	0.40	300
66	3,990	210	430	0.48	250
72	3,350	190	390	0.57	210
84	2,460	160	340	0.78	150
96	–	140	300	1.03	120
108	–	130	260	1.27	90
120	–	110	240	1.61	70

\*Load limited by spot weld shear.

# CHANNEL



**General Information**  
 Finish: Plain, painted green or pre-galvanized  
 Stock Length: 10' and 20', other lengths on request  
 Order By: Part No., Length & Finish



## PS 520 – Steel Channel (1 5/8" x 13/16" x 12 ga.)

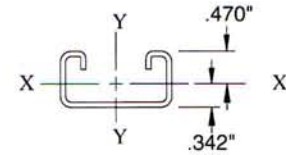
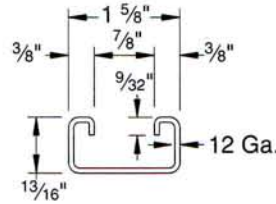

### ELEMENTS OF SECTION

Weight (lbs./100 ft.)	Area of Section (Inch <sup>2</sup> )	X-X Axis			Y-Y Axis		
		Moment of Inertia (Inch <sup>4</sup> )	Section Modulus (Inch <sup>3</sup> )	Radius of Gyration (Inch)	Moment of Inertia (Inch <sup>4</sup> )	Section Modulus (Inch <sup>3</sup> )	Radius of Gyration (Inch)
128	0.376	0.033	0.068	0.297	0.115	0.142	0.554

Modulus of Elasticity: 29,000,000 PSI

### PS 520 H – Channel with Holes

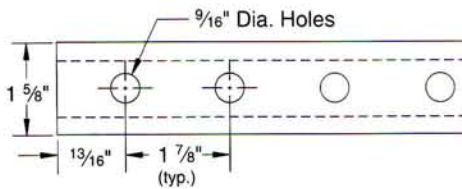

Weight: 123 lbs./100 ft.

### PS 520 EH – Channel with Elongated Holes

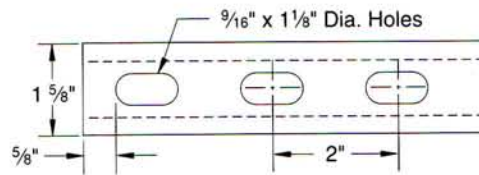

Weight: 123 lbs./100 ft.

### PS 520 S – Channel with Slots

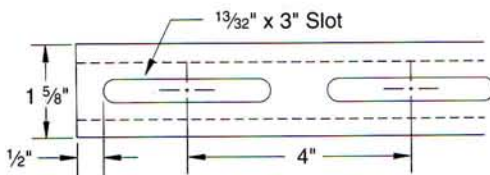

Weight: 118 lbs./100 ft.



General Information  
 Finish: Plain, painted green or pre-galvanized  
 Stock Length: 10' and 20', other lengths on request  
 Order By: Part No., Length & Finish



**PS 520 – BEAM & COLUMN LOADS**

For Pierced Channels,  
 reduce beam load  
 values as follows:

- PS-520-EH      15%
- PS-520-S      15%
- PS-520-H      10%

Span, or Column Inches	Column Load	Dynamic Beam Load X-X Axis	Static Beam Load X-X Axis		
	Maximum Load Lbs.	Uniform Load Lbs. @ 12,000 PSI Stress	Uniform Load Lbs. @25,000 PSI Stress	Deflection Inches @25,000 PSI Stress	Uniform Load Lbs @ 1/240 Span Deflection
12	7,740	550	1,140	0.03	–
18	7,140	360	760	0.06	–
24	6,290	270	570	0.11	540
30	5,200	220	460	0.16	350
36	3,880	180	380	0.24	240
42	2,850	160	330	0.32	180
48	2,180	140	290	0.42	140
54	1,720	120	250	0.53	110
60	–	110	230	0.66	90
66	–	100	210	0.80	70
72	–	90	190	0.95	60
84	–	80	160	1.29	40
96	–	70	140	1.69	30
108	–	60	130	2.13	30
120	–	50	110	2.63	20

Column loads are for allowable axial loads and must be reduced for eccentric loading. For concentrated load at center of span, divide uniform load by 2 and multiply corresponding deflection by 0.8. Dynamic loads should be used for design when the channel is used for support of plumbing, heating, process or power piping. This load table is based on a solid channel section.

**PS 520 – CRUSH LOADS**

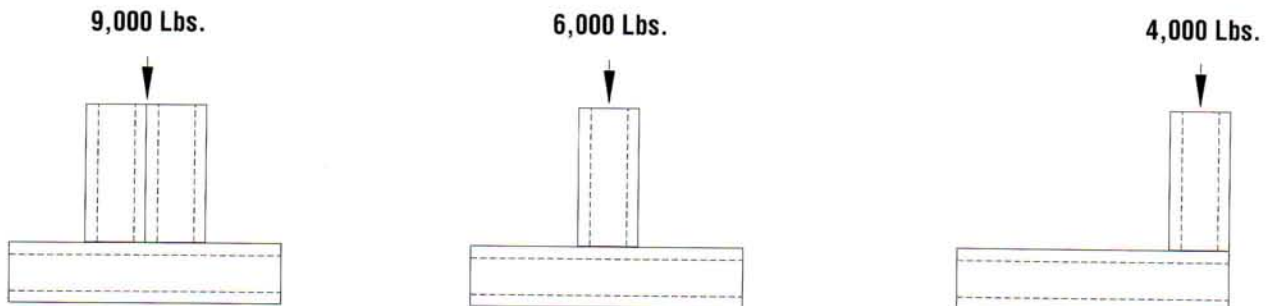

**Resistance to Slip:** 1,500 lbs. per bolt when 1/2" PS NS channel nuts are used.  
**Pull Out Strength:** 1,500 lbs. per bolt when 1/2" PS NS channel nuts are used.

# CHANNEL

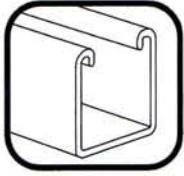

**General Information**  
 Finish: Plain, painted green or pre-galvanized  
 Stock Length: 10' and 20', other lengths on request  
 Order By: Part No., Length & Finish



## PS 520 2T3 – Steel Channel (1 5/8" x 1 5/8" x 12 ga.)

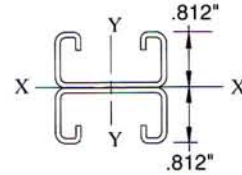
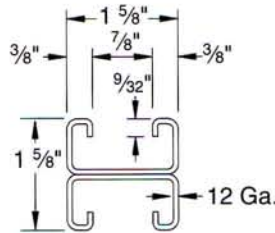
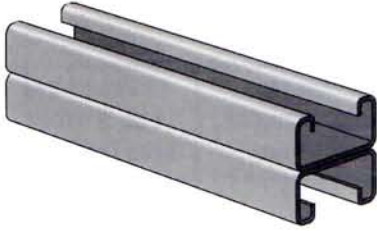

### ELEMENTS OF SECTION

Weight (lbs./100 ft.)	Area of Section (Inch <sup>2</sup> )	X-X Axis			Y-Y Axis		
		Moment of Inertia (Inch <sup>4</sup> )	Section Modulus (Inch <sup>3</sup> )	Radius of Gyration (Inch)	Moment of Inertia (Inch <sup>4</sup> )	Section Modulus (Inch <sup>3</sup> )	Radius of Gyration (Inch)
256	0.752	0.0148	0.182	0.444	0.230	0.284	0.554

Modulus of Elasticity: 29,000,000 PSI

### BEAM & COLUMN LOADS

Span, or Column Inches	Column Load	Dynamic Beam Load X-X Axis	Static Beam Load X-X Axis		
	Maximum Load Lbs.	Uniform Load Lbs. @ 12,000 PSI Stress	Uniform Load Lbs. @25,000 PSI Stress	Deflection Inches @25,000 PSI Stress	Uniform Lbs @ 1/240 Span Deflection
12	16,020	1,470	1,520 *	0.01	–
18	15,470	980	1,520 *	0.03	–
24	14,720	730	1,520 *	0.07	–
30	13,740	590	1,220	0.10	–
36	12,550	490	1,020	0.14	–
42	11,140	420	870	0.20	790
48	9,520	370	760	0.25	610
54	7,710	330	680	0.32	480
60	6,240	290	610	0.40	390
66	5,160	270	560	0.48	320
72	4,340	240	510	0.57	270
84	3,190	210	440	0.78	200
96	–	180	380	1.01	150
108	–	160	340	1.28	120
120	–	150	310	1.60	100

Column loads are for allowable axial loads and must be reduced for eccentric loading. For concentrated load at center of span, divide uniform load by 2 and multiply corresponding deflection by 0.8. Dynamic loads should be used for design when the channel is used for support of plumbing, heating, process or power piping. This load table is based on a solid channel section.

\*Load limited by spot weld shear.



**General Information**

Finish: Plain, painted green or pre-galvanized  
 Stock Length: 10' and 20', other lengths on request  
 Order By: Part No., Length & Finish



**PS 560 – Steel Channel (1 5/8" x 13/16" x 16 ga.)**

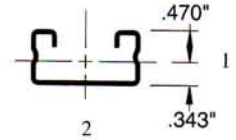
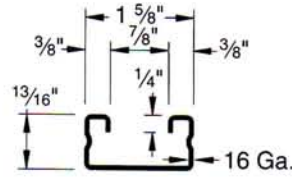
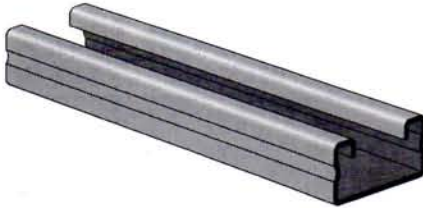

**ELEMENTS OF SECTION**

Modulus of Elasticity: 29,000,000 PSI

Weight (lbs./100 ft.)	Area of Section (Inch <sup>2</sup> )	X-X Axis			Y-Y Axis		
		Moment of Inertia (Inch <sup>4</sup> )	Section Modulus (Inch <sup>3</sup> )	Radius of Gyration (Inch)	Moment of Inertia (Inch <sup>4</sup> )	Section Modulus (Inch <sup>3</sup> )	Radius of Gyration (Inch)
82	0.239	0.023	0.048	0.308	0.091	0.112	0.617

**PS 560 H – Channel with Holes**

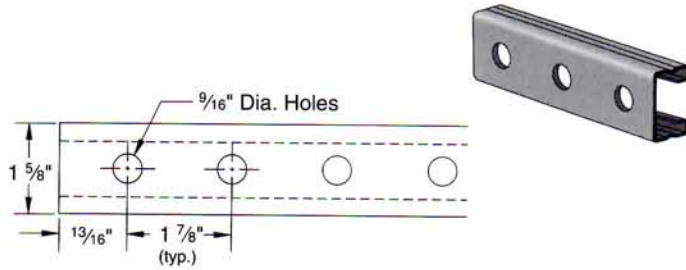

Weight: 79 lbs./100 ft.

**PS 560 EH – Channel with Elongated Holes**

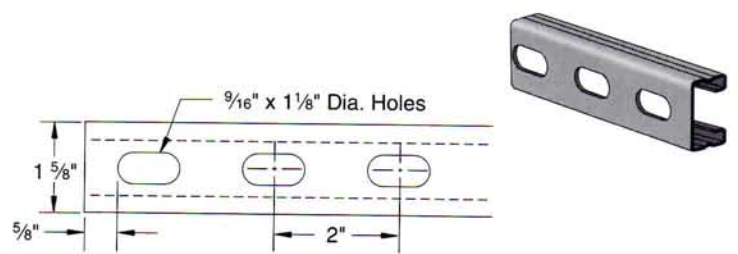

Weight: 79 lbs./100 ft.

**PS 560 S – Channel with Slots**

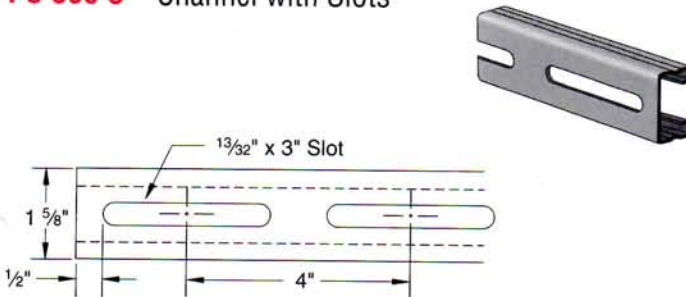

Weight: 79 lbs./100 ft.

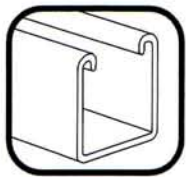

**PS 560 – BEAM & COLUMN LOADS**

**BEAM & COLUMN LOADS**

Span, or Column Inches	Column Load	Dynamic Beam Load X-X Axis	Static Beam Load X-X Axis		
	Maximum Load Lbs.	Uniform Load Lbs. @ 12,000 PSI Stress	Uniform Load Lbs. @25,000 PSI Stress	Deflection Inches @25,000 PSI Stress	Uniform Lbs @ 1/240 Span Deflection
12	4,820	390	810	0.03	–
18	4,320	260	540	0.06	–
24	3,610	190	400	0.11	380
30	2,700	150	320	0.17	240
36	1,880	130	270	0.24	170
42	1,380	110	230	0.33	120
48	1,060	100	200	0.43	90
54	830	90	180	0.54	70
60	680	80	160	0.67	60
66	–	70	150	0.81	50
72	–	60	130	0.96	40
84	–	60	120	1.31	30
96	–	50	100	1.71	20
108	–	40	90	2.17	20
120	–	40	80	2.68	20

Column loads are for allowable axial loads and must be reduced for eccentric loading. For concentrated load at center of span, divide uniform load by 2 and multiply corresponding deflection by 0.8. Dynamic loads should be used for design when the channel is used for support of plumbing, heating, process or power piping. This load table is based on a solid channel section.

**PS 560 – CRUSH LOADS**

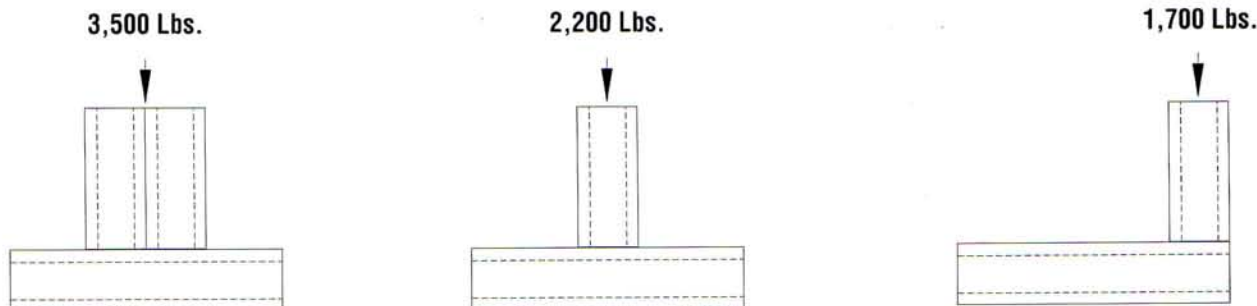

**Resistance to Slip:** 1,000 lbs. per bolt when 1/2" PS NS channel nuts are used.  
**Pull Out Strength:** 1,000 lbs. per bolt when 1/2" PS NS channel nuts are used.





**PS 560 2T3 – Steel Channel (1 5/8" x 1 5/8" x 12 ga.)**

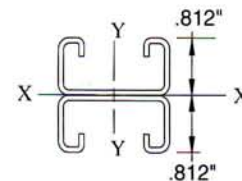
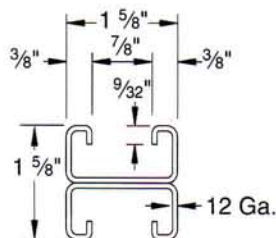

**ELEMENTS OF SECTION**

Weight (lbs./100 ft.)	Area of Section (Inch <sup>2</sup> )	X-X Axis			Y-Y Axis		
		Moment of Inertia (Inch <sup>4</sup> )	Section Modulus (Inch <sup>3</sup> )	Radius of Gyration (Inch)	Moment of Inertia (Inch <sup>4</sup> )	Section Modulus (Inch <sup>3</sup> )	Radius of Gyration (Inch)
256	0.478	0.101	0.125	0.460	0.182	0.2224	0.617

Modulus of Elasticity: 29,000,000 PSI

**BEAM & COLUMN LOADS**

Span, or Column Inches	Column Load	Dynamic Beam Load X-X Axis	Static Beam Load X-X Axis		
	Maximum Load Lbs.	Uniform Load Lbs. @ 12,000 PSI Stress	Uniform Load Lbs. @25,000 PSI Stress	Deflection Inches @25,000 PSI Stress	Uniform Lbs @ 1/240 Span Deflection
12	10,200	690 *	690 *	0.01	–
18	9,880	670	690 *	0.02	–
24	9,430	500	690 *	0.04	–
30	8,850	400	690 *	0.08	–
36	8,150	330	690 *	0.14	–
42	7,310	290	600	0.20	540
48	6,350	250	520	0.25	410
54	5,260	220	470	0.33	330
60	4,260	200	420	0.40	260
66	3,520	180	380	0.48	220
72	2,960	170	350	0.57	180
84	2,170	140	300	0.78	140
96	–	130	260	1.01	80
108	–	110	230	1.27	70
120	–	100	210	1.59	–

Column loads are for allowable axial loads and must be reduced for eccentric loading. For concentrated load at center of span, divide uniform load by 2 and multiply corresponding deflection by 0.8. Dynamic loads should be used for design when the channel is used for support of plumbing, heating, process or power piping. This load table is based on a solid channel section.

\*Load limited by spot weld shear.

# CHANNEL



**PS 6153** – Strut Safety End Cap  
(For OSHA Req'd End of Hand Rail)

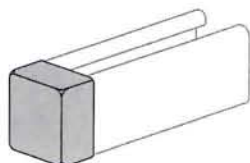

Part No.	Use With	Weight (lbs/100 pcs.)
PS-6153-1	PS-100	5.0
PS-6153-2	PS-200, PS-210	2.8
PS-6153-3	PS-300	2.5
PS-6153-5	PS-500, PS-520, PS560	2.0

Material: Red Colored PVC

**PS 6152** – Decorative End Cap

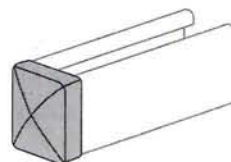

Finish: Electro-galvanized  
Use With: PS-200, PS-210

Weight: 10 lbs./100 pcs.

**PS 3792** – Power-Wrap™

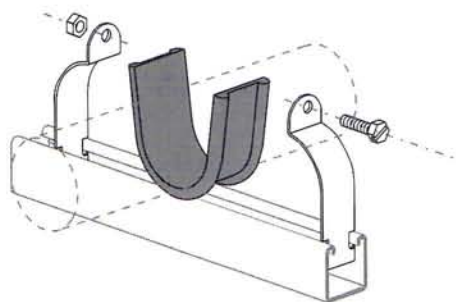

Material: EPDM  
Stock Thickness: 1/8"  
Stock Length: 25 ft./box  
Service Temp: -70° to 350°F

Weight: 253 lbs./100 boxes

**PS 9050** – Green Touch-up Spray Paint



Weight: 75 lbs./100 cans



# FASTENERS



## Materials & Manufacturing Specifications

### GENERAL:

Power-Strut clamping nuts are cold formed from mild steel bar stock to produce a nut of greater strength and holding power. Two grooves in the nut are formed, each with six sharp teeth and then case hardened. These sharp hardened teeth bite into the inturned edges of the Power-Strut channel giving greater resistance to slippage. Power-Strut clamping nuts also have great pull-out resistance due to the type of steel and design used.

### MATERIAL:

Channel clamping nuts meet ASTM A-576 GR1015M, and are case hardened. Hex head bolts meet SAE J429 GR 2 and ASTM A307. Square and hex nuts meet ASTM A563 GR A.

### SCREW THREADS DATA:

All Power-Strut nuts and bolts are manufactured to meet the Unified Screw Threads standard, ANSI B1.1, Coarse Series UNC, class 2. Continuous Threaded Rod: Meets ASTM A-510

### STANDARD FINISH:

All fasteners have an electro-galvanized finish.

### ORDERING INFORMATION:

When ordering, add the length or size and finish to the part number. See page 5 for finish abbreviations and an example.

### RECOMMENDED TORQUE:

Bolt Size	1/4"-20	5/16"-18	3/8"-16	1/2"-13
Foot Pounds	6	11	19	50

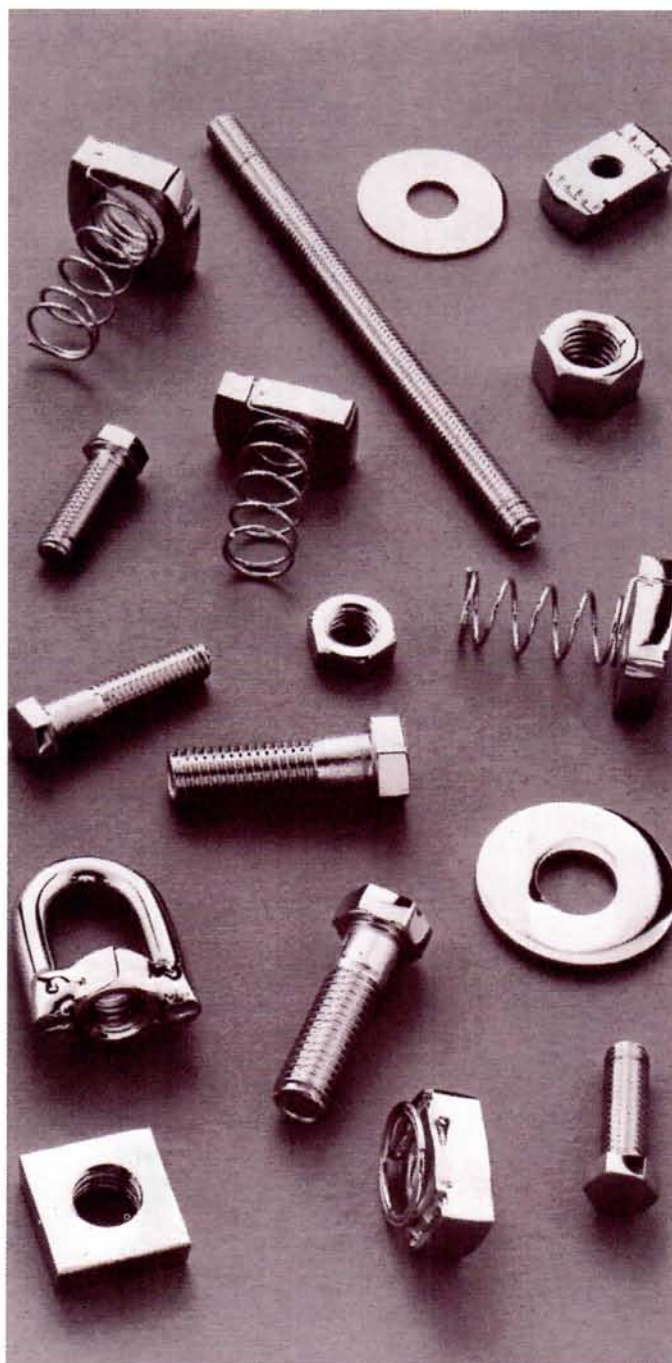

# FASTENERS



## General Information

Standard Finish: Electro-galvanized  
Order By: Part No., Size & Finish



### PS 6024 – Hex Head Cap Screw



Size	Wt./ 100 pcs
1/4 x 3/4"	1.5
1/4 x 1"	1.8
1/4 x 1 1/4"	2.1
1/4 x 1 1/2"	2.4
3/8 x 3/4"	3.6
3/8 x 1"	4.2
3/8 x 1 1/4"	4.9
3/8 x 1 1/2"	5.6
3/8 x 2"	7.2
1/2 x 3/4"	8.1
1/2 x 1"	9.2
1/2 x 1 1/4"	10.4
1/2 x 1 1/2"	11.6
1/2 x 1 3/4"	13.0
1/2 x 2"	14.4

### PS 6072 – Round Head Machine Screw



Size	Wt./ 100 pcs
1/4 x 3/4"	1.3
1/4 x 1"	1.6
1/4 x 1 1/4"	1.9
3/8 x 1"	4.4
3/8 x 1 1/4"	5.0
3/8 x 1 1/2"	5.6

### PS 6075 – Slotted Hex Head Machine Screw



Size	Wt./ 100 pcs
1/4 x 3/4"	1.7
5/16 x 1"	2.6
5/16 x 1 1/4"	3.0
5/16 x 1 1/2"	3.4
3/8 x 1 1/4"	5.3

### PS 6108 – Square Nut



Size	Wt./ 100 pcs
1/4"	.9
5/16"	1.6
3/8"	2.6
1/2"	5.8



**General Information**

Standard Finish: Electro-galvanized  
Order By: Part No., Size & Finish



**PS 6064 – Square Head Cone Point Set Screw**



Size	Wt./ 100 pcs
3/8 x 1 1/2"	4.5
3/8 x 2"	6.1
1/2 x 1 1/2"	8.5
1/2 x 2"	11.4

**PS 146 – Continuous Threaded Rod**



Rod Size	Load Rating Lbs.	Wt./100 pcs.	
		6' Lengths	10' Lengths
1/4"	240	73	121
3/8"	610	175	292
1/2"	1130	319	531
5/8"	1810	504	840
3/4"	2710	740	1234

Finish: Plain or electro-galvanized  
Standard Length: 6' or 10'; Other lengths available

**PS 3500 3/8"-5/8" – Seismic Rod Stiffener**

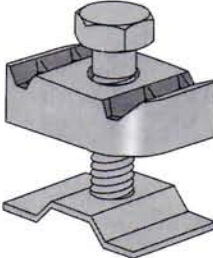

Hanger rod stiffener assembly for 3/8" thru 5/8" threaded rod.

Part No.	Wt./100 pcs
PS 3500 3/8"-5/8"	16

**PS 135 – Rod Coupling**

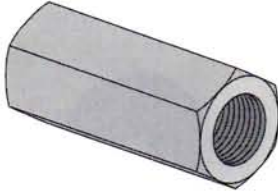

Rod Size	Load Rating lbs.	Wt./ 100 pcs.
1/4"	240	2
3/8"	610	9
1/2"	1130	10
5/8"	1810	18
3/4"	2710	28

# FASTENERS



## General Information

Standard Finish: Electro-galvanized  
Order By: Part No., Size & Finish



### PS 83 – Hexagon Nut



Size	Wt./ 100 pcs
1/4"	0.7
3/8"	1.6
1/2"	3.8
5/8"	7.3
3/4"	11.9

Finish: Plain or electro-galvanized

### PS 230 – Fender Washer



Size	Outside Diameter	Wt./ 100 pcs
1/4"	1 1/2"	3.3
3/8"	1 1/2"	3
1/2"	1 1/2"	2.8

### PS 209 – Flat Washer



Size	Outside Diameter	Wt./ 100 pcs
1/4"	3/4"	0.7
3/8"	1"	1.5
1/2"	1 3/8"	3.9
5/8"	1 3/4"	7.7
3/4"	2"	11

### PS 211 – Lock Washer



Size	Wt./ 100 pcs
1/4"	0.3
3/8"	0.7
1/2"	1.5



**General Information**

Standard Finish: Electro-galvanized  
Order By: Part No., Size & Finish

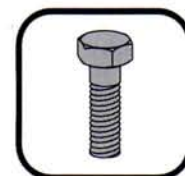

**PS LS – Clamping Nut with Long Spring**

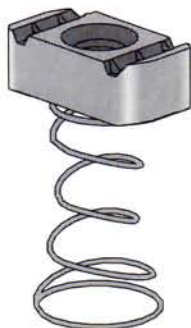

Size	Threads	Wt./ 100 pcs
1/4"	20	7.5
3/8"	16	10.2
1/2"	13	12.3
5/8"	11	15.8
3/4"	10	14.1

Use With: PS 100 and PS 150 Channel.

**PS TG, PS TGS – Top Grip™ Nut with Spring on Top**

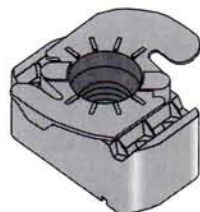

Part No.	Size	Threads	Wt./ 100 pcs
PSTG 1/4	1/4"	20	7
PSTG 3/8	3/8"	16	10
PSTG 1/2*	1/2"	13	8

Use With: All 1 5/8" Channel.

\*PS TG 1/2" nut has a 3/8" body thickness

**PS RS – Clamping Nut with Regular Spring**



Size	Threads	Wt./ 100 pcs
#8-32	32	7.2
#10-24	24	7.2
#10-32	32	7.2
1/4"	20	7.1
5/16"	18	7
3/8"	16	9.9
1/2"	13	11.9
5/8"	11	15.5
3/4"	10	13.8
7/8"	9	14.3

Use With: PS 200, PS 210 and PS 300 Channel.

**PS 3281 – Double Conveyor Adjusting Nut**

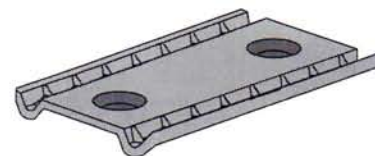

Size	Threads	Wt./ 100 pcs
3/8"	16	17.5

Use With: All 1 5/8" channel.

# FASTENERS



## General Information

Standard Finish: Electro-galvanized  
Order By: Part No., Size & Finish



### PS SS – Clamping Nut with Short Spring



Size	Threads	Wt./ 100 pcs
#8-32	32	7.0
#10-24	24	7.0
#10-32	32	7.0
1/4"	20	6.9
5/16"	18	6.7
3/8"	16	9.6
1/2"	13 *	8.8
5/8"	11 *	11.5

Use With: PS 400, PS 500 and PS 520 channel.

\*PSSS 1/2" and PSSS 5/8" nuts have 3/8" body thickness.

### PS NS – Clamping Nut without Spring

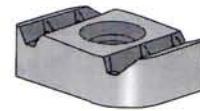

Size	Threads	Wt./ 100 pcs
#10-24	24 *	6.7
1/4"	20 *	6.6
5/16"	18 *	6.4
3/8"	16 *	9.3
1/2"	13	11.4
5/8"	11	15.2
3/4"	10	13.0
7/8"	9	14.0

Use With: PS 100, PS 150, PS 200, PS 210 and PS 300 channel.

\*Can be used with PS 400, PS 500 and PS 520 channel.

### PS 517 – Channel Nut with Stud

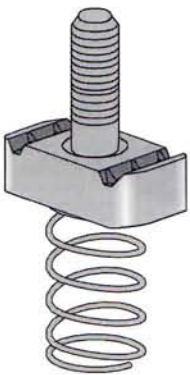

Size	Wt./ 100 pcs
1/4" x 1"	8.1
1/4" x 1 1/4"	8.3
1/4" x 1 1/2"	8.6
1/4" x 2"	9.1
3/8" x 1"	13.0
3/8" x 1 1/4"	14.0
3/8" x 1 1/2"	14.0
3/8" x 2"	15.0
1/2" x 1"	15.0
1/2" x 1 1/4"	16.0
1/2" x 1 1/2"	17.0
1/2" x 2"	19.0

Use With: PS 200, PS 210 and PS 300 channel.

### PS NS S – Shallow Clamping Nut without Spring



Size	Threads	Wt./ 100 pcs
1/2"	13	6.9
5/8"	11	9.7
3/4"	10	8.4

Use With: PS 500 and PS 520 channel.





**General Information**

Standard Finish: Electro-galvanized  
Order By: Part No., Size & Finish



**PS 202 – Eyelet**

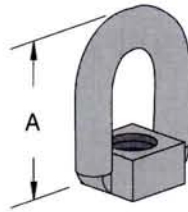

Rod Size	A	Stock Dia.	Load Rating lbs.	Wt./ 100 pcs
3/8"	1 3/4	3/8"	610	15
1/2"	1 3/4	3/8"	610	18

**PS 205 – Eyelet with Stud**

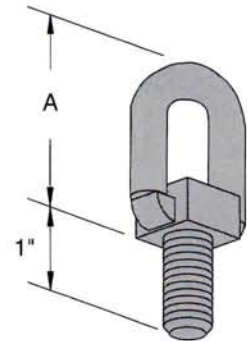

Rod Size	A	Stock Dia.	Load Rating lbs.	Wt./ 100 pcs
3/8"	1 13/16	3/8"	610	16
1/2"	1 3/4	3/8"	610	20

**PS 204 – Linked Eyelets**

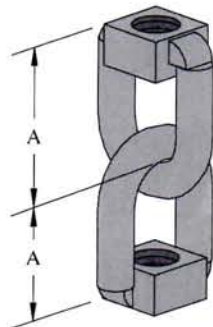

Rod Size	A	Stock Dia.	Load Rating lbs.	Wt./ 100 pcs
3/8"	1 7/16	3/8"	610	23
1/2"	1 3/8	3/8"	610	32

**PS 203 – Linked Eyelet with Stud**

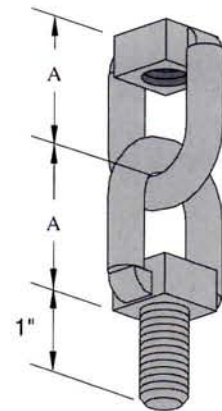

Rod Size	A	Stock Dia.	Load Rating lbs.	Wt./ 100 pcs
3/8"	1 7/16	3/8"	610	27
1/2"	1 3/8	3/8"	610	45

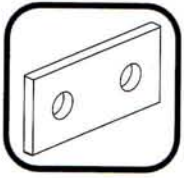

# FITTINGS



## Materials & Manufacturing Specifications

### **MATERIAL:**

All Power-Strut fittings are formed in punch press dies from mild, pickled and oiled, bar or strip steel. Plain or electro-galvanized fittings meet the requirements for ASTM A-575 and A-576, or ASTM A-36.

### **STANDARD DIMENSIONS:**

Standard dimensions on all fittings are as follows except where otherwise indicated:

Fitting Thickness: 1/4"  
Fitting Width: 1 5/8"  
Hole Diameter: 9/16"  
Hole Spacing: 1 7/8" on centers and 13/16" from ends.

### **STANDARD FINISH:**

All Power-Strut fittings are available in painted green or electro-galvanized finish.

### **ORDERING INFORMATION:**

When ordering, add the length or size and finish to the part number. See page 5 for finish abbreviations and an example.

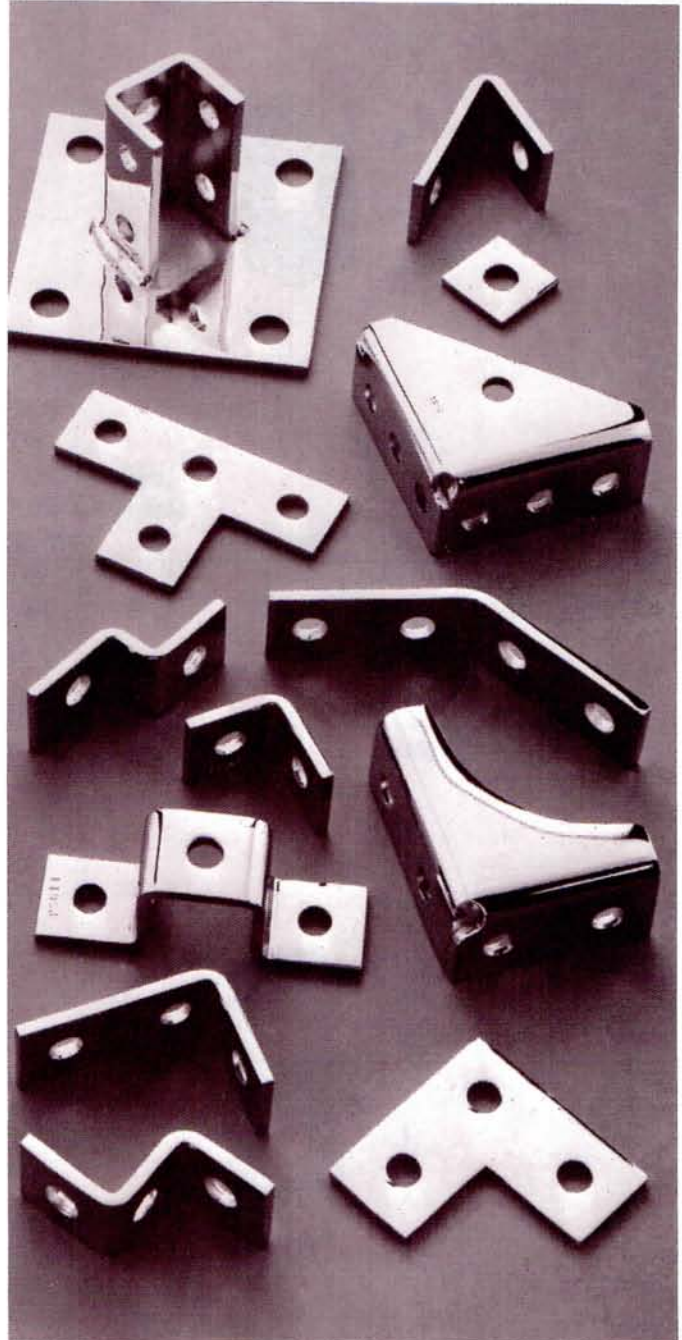



# FLAT PLATE FITTINGS

General Information  
 Stock Width: 1 5/8"  
 Fitting Thickness: 1/4"  
 Finish: Painted green or electro-galvanized  
 Hole Diameter: 9/16"  
 Hole Spacing: 13/16" from end, 1 7/8" on center  
 Order By: Part No., Size & finish

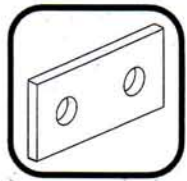

## PS 619 – Square Washer

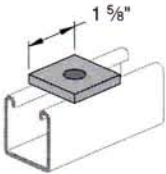

Note: Indicate rod size when ordering.  
 For example, PS 619 1/4.

Rod Size	Hole Size	Wt./100 pcs
1/4	11/32"	18
3/8	7/16"	18
1/2	9/16"	17
5/8	11/16"	16
3/4	13/16"	15

## PS 2504 – Guided Square Washer

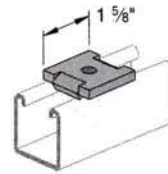

Note: Indicate rod size when ordering.  
 For example, PS 619 1/4.

Rod Size	Hole Size	Wt./100 pcs
1/4	11/32"	18
3/8	7/16"	18
1/2	9/16"	17

## PS 601 – Two-Hole Splice Plate

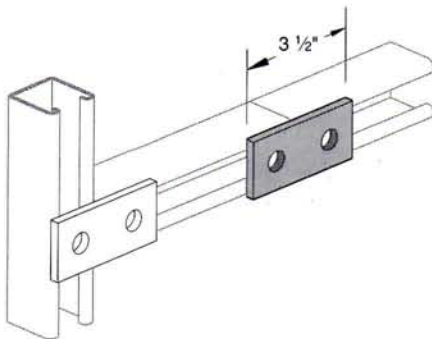

Weight/100 pcs: 38 lbs.

## PS 602 – Three-Hole Splice Plate

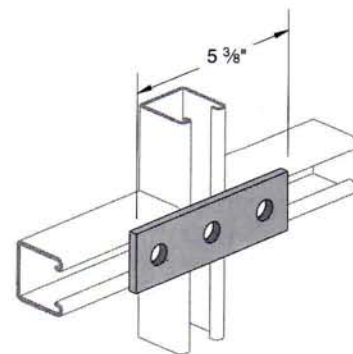

Weight/100 pcs: 50 lbs.

## PS 618 – Two-Hole Swivel Plate

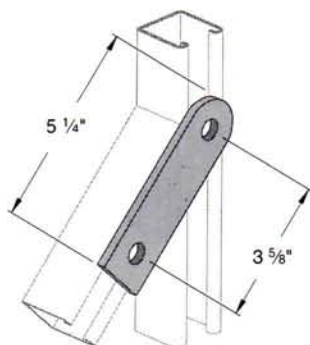

Weight/100 pcs: 55 lbs.

## PS 617 – Three-Hole Swivel Plate

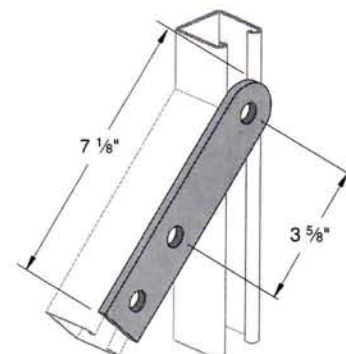

Weight/100 pcs: 75 lbs.

# FLAT PLATE FITTINGS

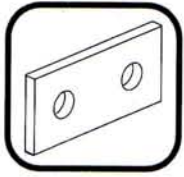

General Information  
Stock Width: 1 5/8"  
Fitting Thickness: 1/4"  
Finish: Painted green or electro-galvanized  
Hole Diameter: 9/16"  
Hole Spacing: 13/16" from end, 1 7/8" on center  
Order By: Part No., Size & finish



## PS 888 – Four-Hole Splice Plate

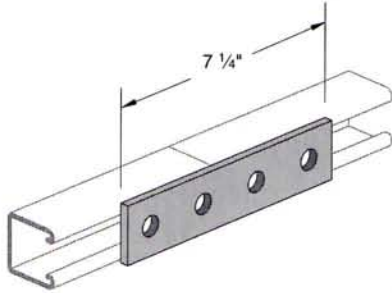

Weight/100 pcs: 78 lbs.

## PS 889 – Five-Hole Splice Plate

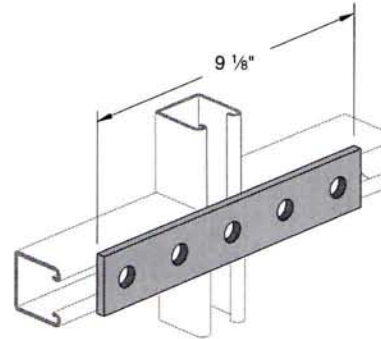

Weight/100 pcs: 94 lbs.

## PS 718 – Flat Angle Plate

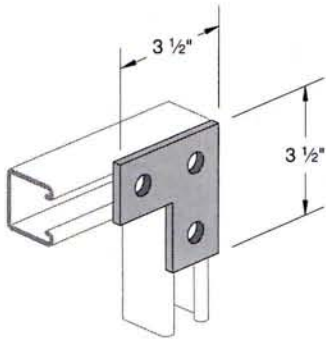

Weight/100 pcs: 58 lbs.

## PS 719 – Flat Angle Plate

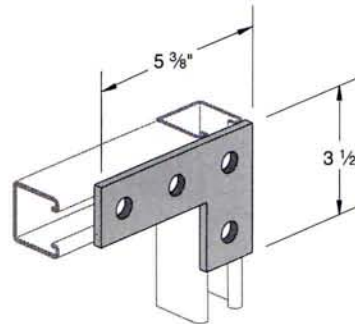

Weight/100 pcs: 80 lbs.

## PS 620 – Two-Hole Connecting Plate

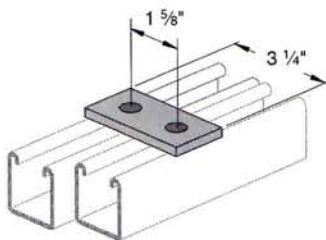

Weight/100 pcs: 35 lbs.

## PS 621 – Four-Hole Connecting Plate

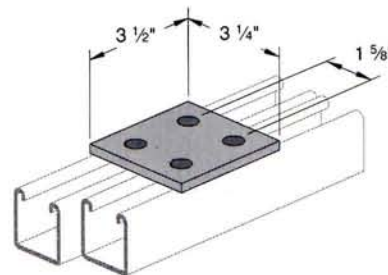

Weight/100 pcs: 73 lbs.



**FLAT PLATE FITTINGS**

General Information  
 Stock Width: 1 5/8"  
 Fitting Thickness: 1/4"  
 Finish: Painted green or electro-galvanized  
 Hole Diameter: 9/16"  
 Hole Spacing: 13/16" from end, 1 7/8" on center  
 Order By: Part No., Size & finish

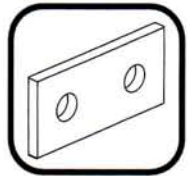

**PS 714** – Tee Plate

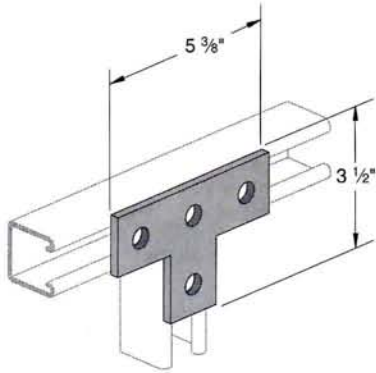

Weight/100 pcs: 80 lbs.

**PS 712** – Cross Plate

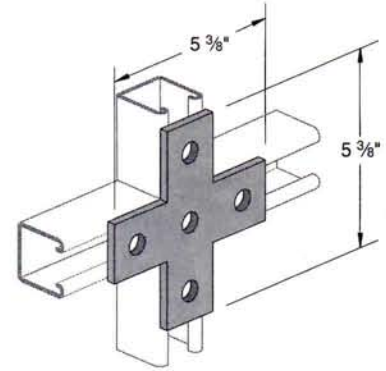

Weight/100 pcs: 105 lbs.

**PS 744** – Flat Corner Connector

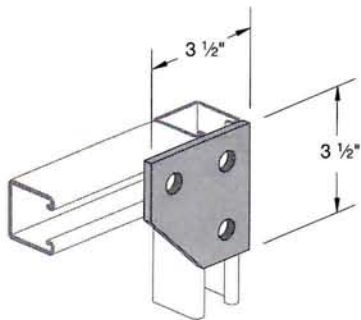

Weight/100 pcs: 70 lbs.

**PS 750** – Four-Hole Corner Connector

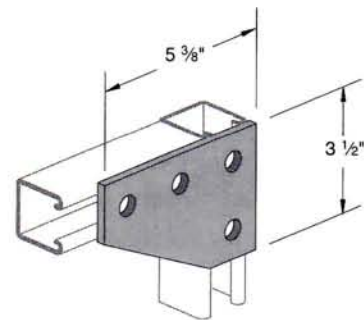

Weight/100 pcs: 105 lbs.

**PS 2190** – Flat Corner Connector

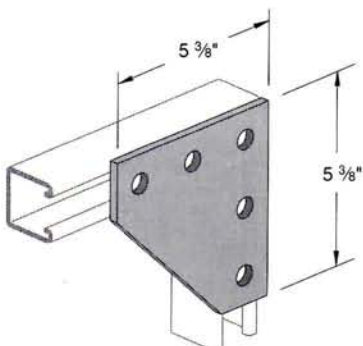

Weight/100 pcs: 150 lbs.

**PS 925** – Symmetrical Three-Hole Joint Connector

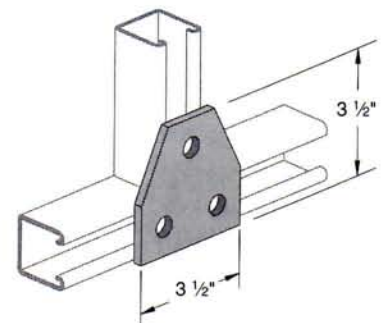

Weight/100 pcs: 70 lbs.

# FLAT PLATE FITTINGS

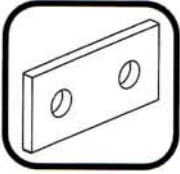

General Information  
Stock Width: 1 5/8"  
Fitting Thickness: 1/4"  
Finish: Painted green or electro-galvanized  
Hole Diameter: 9/16"  
Hole Spacing: 13/16" from end, 1 7/8" on center  
Order By: Part No., Size & finish



## PS 747 – Symmetrical Four-Hole Connector

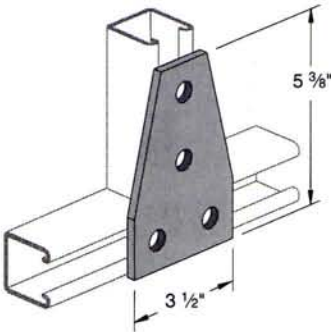

Weight/100 pcs: 105 lbs.

## PS 854 – Flat Connector

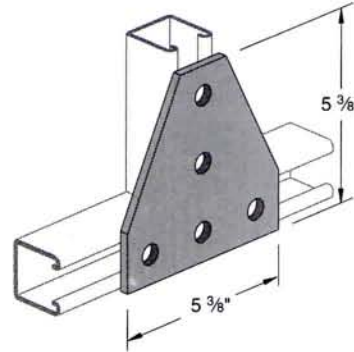

Weight/100 pcs: 148 lbs.

## PS 2112 – Cross Connector

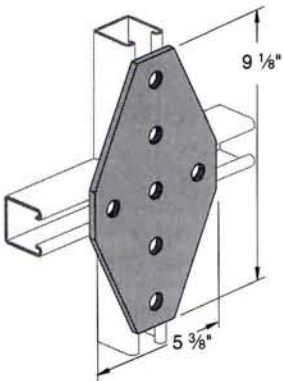

Weight/100 pcs: 240 lbs.

## PS 822 – Double 45° Connector

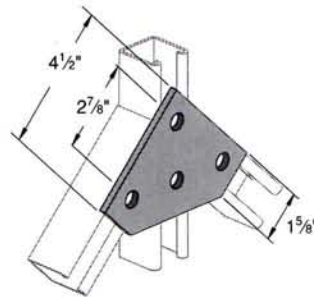

Weight/100 pcs: 112 lbs.



General Information  
 Stock Width: 1 5/8"  
 Fitting Thickness: 1/4"  
 Finish: Painted green or electro-galvanized  
 Hole Diameter: 9/16"  
 Hole Spacing: 13/16" from end, 1 7/8" on center  
 Order By: Part No., Size & finish

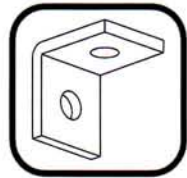

**PS 921 – One-Hole Angle**

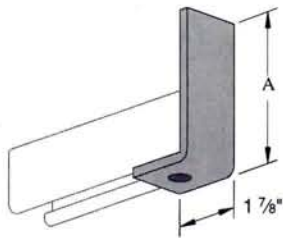

A	Wt./100 pcs
3 7/8"	61
5 7/8"	84
7 7/8"	107
9 7/8"	130

**PS 603 – Two-Hole End Angle**

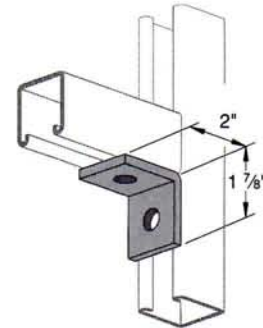

Weight/100 pcs: 38 lbs.

**PS 604 – Two-Hole Corner Angle**

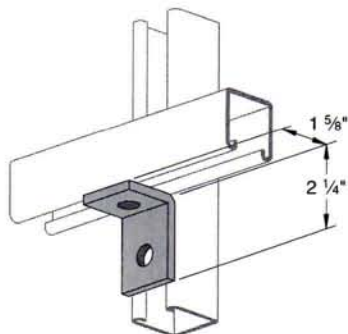

Weight/100 pcs: 38 lbs.

**PS 2144 – Corner Angle**

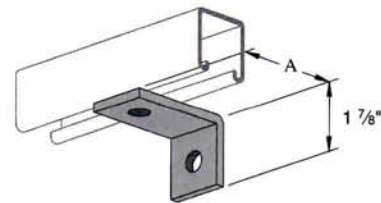

A	Wt./100 pcs
3"	49
3 1/2"	54
4"	61

**PS 763 – Slotted Adjustment Angle**

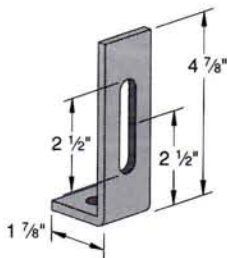

Weight/100 pcs: 65 lbs.

**PS 764 – Slotted Adjustment Angle**

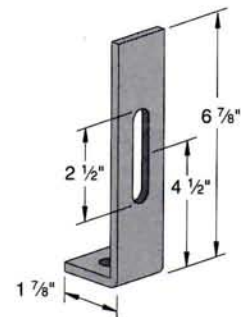

Weight/100 pcs: 85 lbs.

# 90° FITTINGS

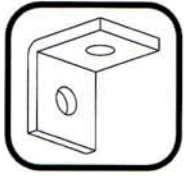

General Information  
 Stock Width: 1 5/8"  
 Fitting Thickness: 1/4"  
 Finish: Painted green or electro-galvanized  
 Hole Diameter: 9/16"  
 Hole Spacing: 13/16" from end, 1 7/8" on center  
 Order By: Part No. & finish



## PS 806 – Self-Aligning Two-Hole Angle

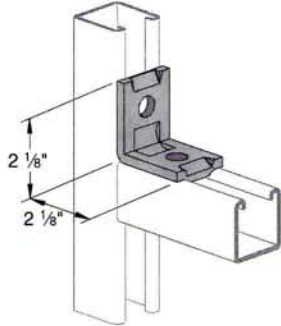

Weight/100 pcs: 40 lbs.

## PS 2520 – Slotted 90° Angle

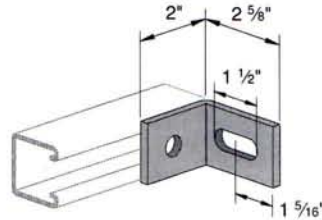

Weight/100 pcs: 42 lbs.

## PS 2545 – Slotted 90° Angle

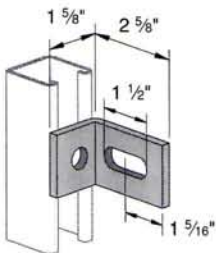

Weight/100 pcs: 38 lbs.

## PS 605 – Three-Hole Corner Angle

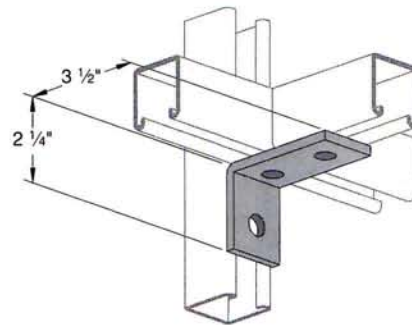

Weight/100 pcs: 58 lbs.

## PS 606 – Three-Hole Corner Angle

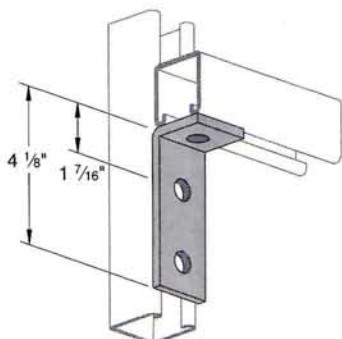

Weight/100 pcs: 58 lbs.

## PS 745 – Three-Hole Corner Angle

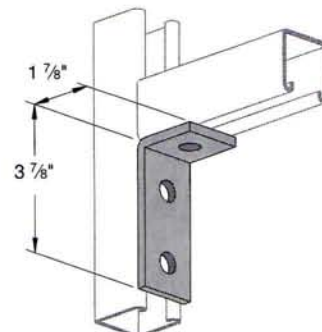

Weight/100 pcs: 58 lbs.





General Information  
 Stock Width: 1 5/8"  
 Fitting Thickness: 1/4"  
 Finish: Painted green or electro-galvanized  
 Hole Diameter: 9/16"  
 Hole Spacing: 13/16" from end, 1 7/8" on center  
 Order By: Part No., & finish

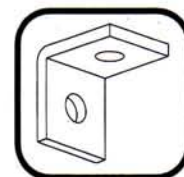

**PS 3049 – Two-Hole Slotted 90° Angle**

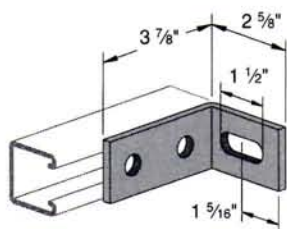

Weight/100 pcs: 66 lbs.

**PS 607 – Four-Hole Corner Angle**

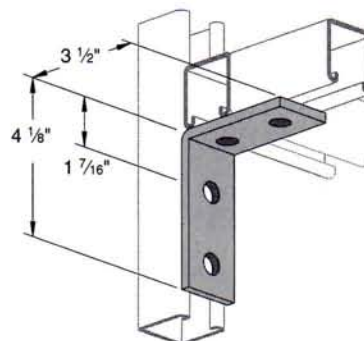

Weight/100 pcs: 78 lbs.

**PS 660 – Four-Hole Corner Angle**

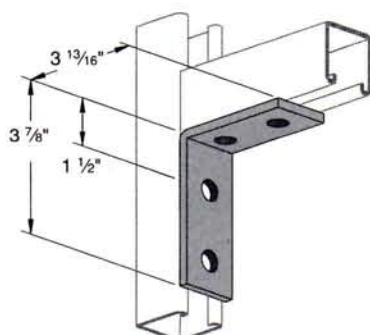

Weight/100 pcs: 78 lbs.

**PS 3373 – Universal Corner Connector**

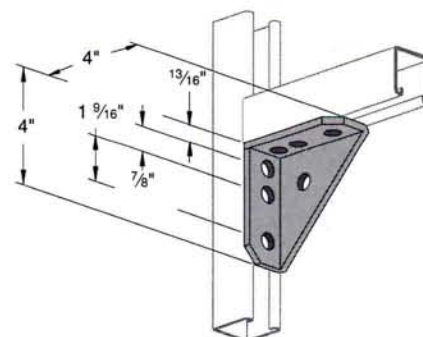

Weight/100 pcs: 134 lbs.

**PS 614 – Four-Hole Joint Angle Connector**

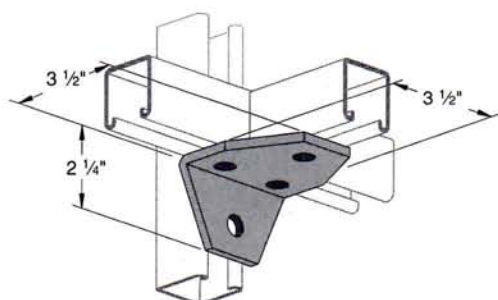

Weight/100 pcs: 103 lbs.

**PS 615 – Five-Hole Joint Angle Connector**

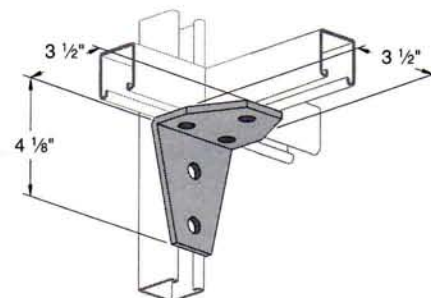

Weight/100 pcs: 135 lbs.

# 90° FITTINGS

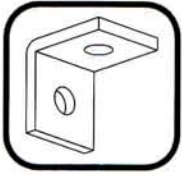

General Information  
 Stock Width: 1 5/8"  
 Fitting Thickness: 1/4"  
 Finish: Painted green or electro-galvanized  
 Hole Diameter: 9/16"  
 Hole Spacing: 13/16" from end, 1 7/8" on center  
 Order By: Part No. & finish



## PS 720 R OR L – Angle Plate Connector

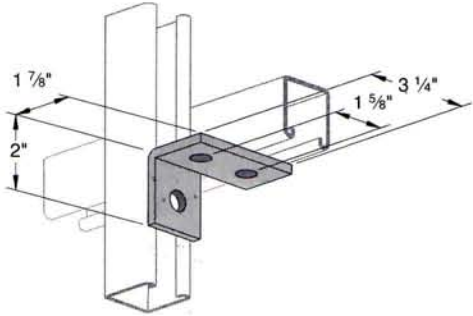

Weight/100 pcs: 55 lbs.  
 NOTE: Specify R (Right) or L (Left) – Right Hand illustrated

## PS 716 R OR L – Angle Tee Plate

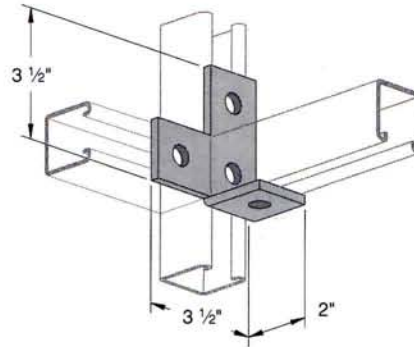

Weight/100 pcs: 80 lbs.

## PS 713 – Cross Plate Angle

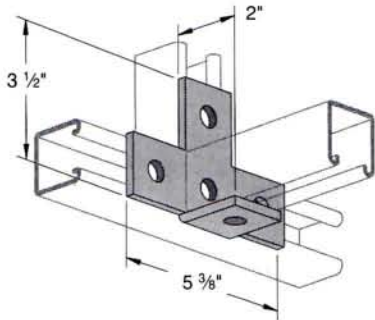

Weight/100 pcs: 105 lbs.

## PS 715 – Tee Plate 90° Angle

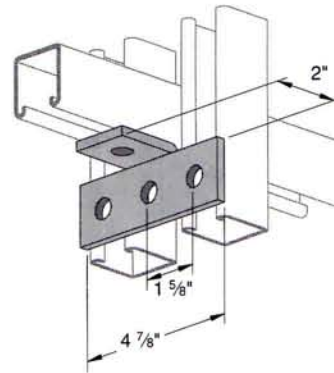

Weight/100 pcs: 71 lbs.

## PS 927 – Five-Hole Corner Connector

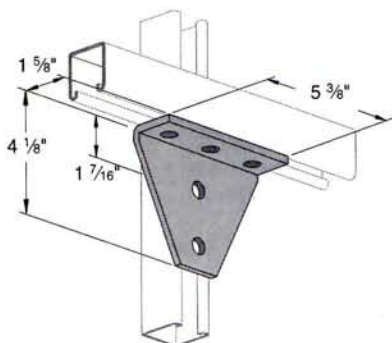

Weight/100 pcs: 154 lbs.

## PS 689A, PS 689B – Double-Slotted Corner Connector

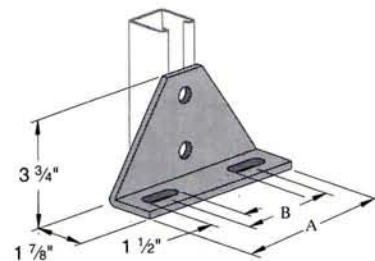

Part No.	A	B	Wt./100 pcs
PS 689 A	6 5/8	4"	190
PS 689 B	8 5/8	6"	242



General Information  
 Stock Width: 1 5/8"  
 Fitting Thickness: 1/4"  
 Finish: Painted green or electro-galvanized  
 Hole Diameter: 9/16"  
 Hole Spacing: 13/16" from end, 1 7/8" on center  
 Order By: Part No. & finish



**PS 752 R OR L – Four-Hole Corner Connector**

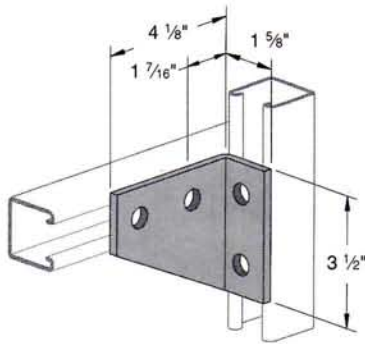

Weight/100 pcs: 105 lbs.

**PS 622 – Four-Hole Corner Connector**

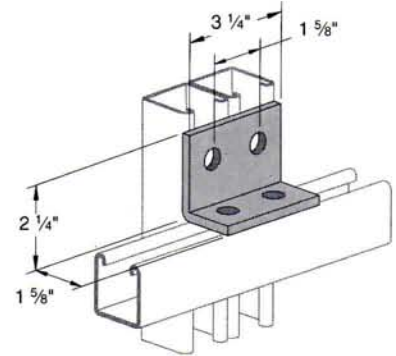

Weight/100 pcs: 75 lbs.

**PS 2007 R OR L – Five-Hole Corner Connector**

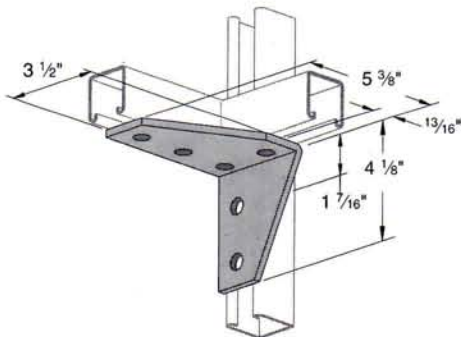

Weight/100 pcs: 160 lbs.

**PS 3326 R OR L – Five-Hole Gussetted Corner Connector**

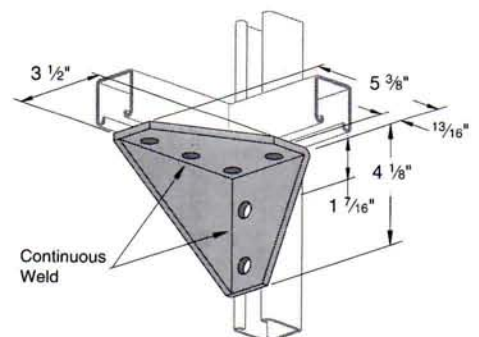

Weight/100 pcs: 230 lbs.

**PS 746 – Three-Hole Corner Joint Connector**

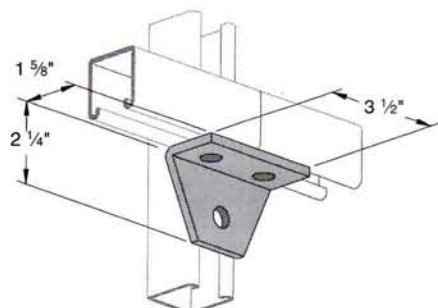

Weight/100 pcs: 70 lbs.

**PS 748 – Four-Hole Corner Joint Connector**

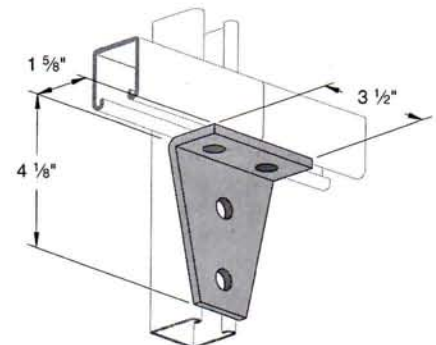

Weight/100 pcs: 105 lbs.

# ANGLE FITTINGS



**General Information**  
 Stock Width: 1 5/8"  
 Fitting Thickness: 1/4"  
 Finish: Painted green or electro-galvanized  
 Hole Diameter: 9/16"  
 Hole Spacing: 13/16" from end, 1 7/8" on center  
 Order By: Part No., Angle & finish



## PS 633 – Two-Hole Open Angle Connector

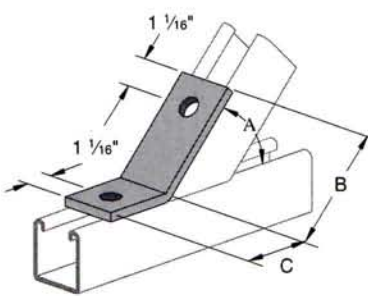

"A" Degree	"B" In	"C" In
82 1/2°	3 9/16	1 11/16
75°	3 9/16	1 11/16
67 1/2°	3 1/2	1 3/4
60°	3 3/8	1 7/8
52 1/2°	3 1/4	2 1/16
45°	3	2 5/16
37 1/2°	3 1/2	1 13/16
37 1/2°	2 11/16	2 5/8
30°	3 1/4	2 1/16
22 1/2°	3 5/16	2 1/16
15°	3 5/16	2 1/16
7 1/2°	3 5/16	2 1/16

Weight/100 pcs: 58 lbs.

## PS 624 – Two-Hole Closed Angle Connector

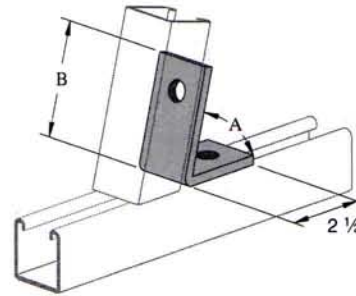

"B" Inch	"A" Angle
3"	37 1/2°
3 1/8"	45°
3 1/16"	52 1/2°
3 1/8"	60°
3 1/8"	67 1/2°
3 3/16"	75°
3 3/16"	82 1/2°

Weight/100 pcs: 58 lbs.

## PS 781 – Four-Hole Open Angle Connector

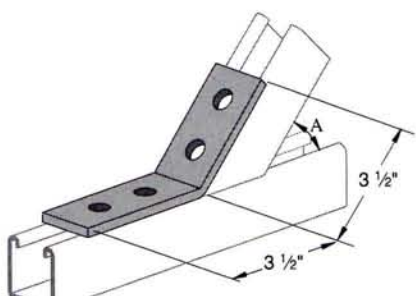

Angle
7 1/2°
15°
22 1/2°
30°
37 1/2°
45°
52 1/2°
60°
67 1/2°
75°
82 1/2°

Weight/100 pcs: 78 lbs.

## PS 793 – Four-Hole Closed Angle Connector

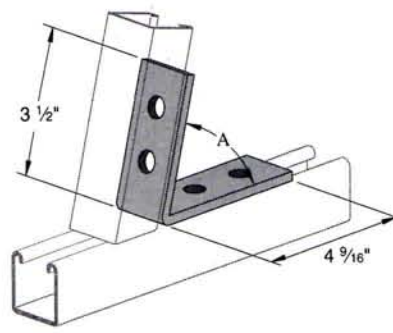

Angle
37 1/2°
45°
52 1/2°
60°
67 1/2°
75°
82 1/2°

Weight/100 pcs: 100 lbs.

## PS 2113 – Slotted Corner Connector

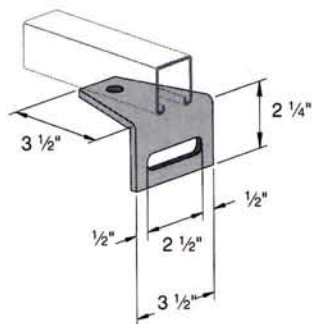

Weight/100 pcs: 97 lbs.

## PS 9400 – Adjustable Brace

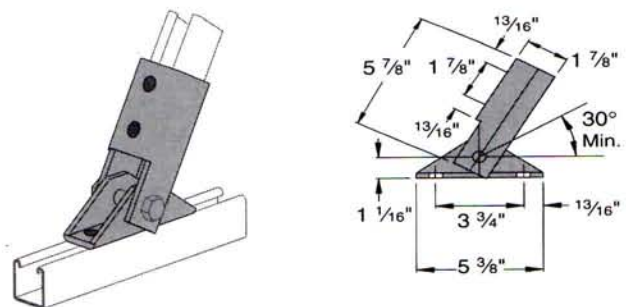

Weight/100 pcs: 307 lbs.



General Information  
 Stock Width: 1 5/8"  
 Fitting Thickness: 1/4"  
 Finish: Painted green or electro-galvanized  
 Hole Diameter: 9/16"  
 Hole Spacing: 13/16" from end, 1 7/8" on center  
 Order By: Part No., Angle & finish



**PS 9401 – Double Adjustable Brace**

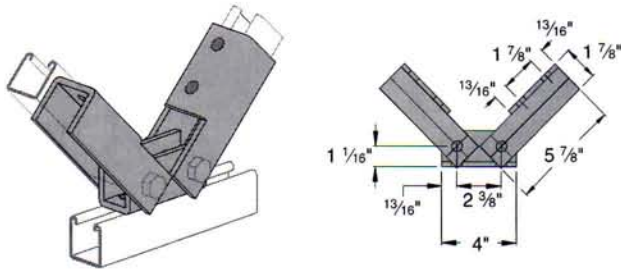

Weight/100 pcs: 497 lbs.

**PS 9403 – Three-Hole Hinge Connector**

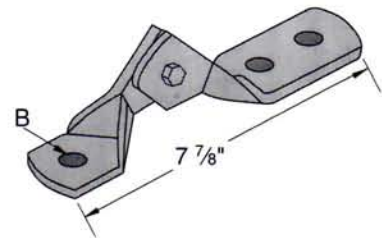

"B" Bolt Size	Wt./ 100 pcs
1/2"	108
5/8"	107
3/4"	106

**PS 9404 – Four-Hole Hinge Connector**

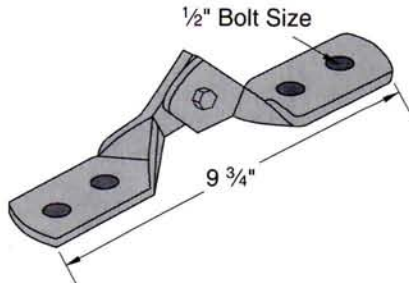

Part No.	Wt./ 100 pcs
PS 9404-1/2"	126

Hinge Connector Auto-Alignment Guides - The unique edges of the two hinges have been designed to provide an alignment guide for 0°, 45° and 90° as shown in the drawings below. This eliminates the need for measuring gages.

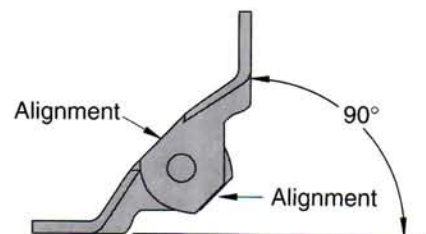
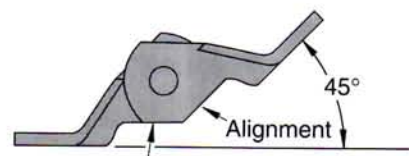
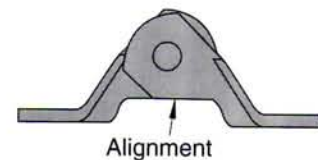

**PS 9402 – Two-Hole Hinge Connector**

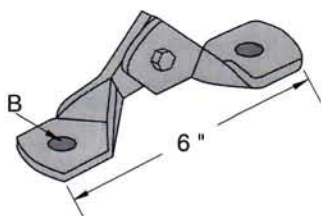

"B" Bolt Size	Wt./ 100 pcs
1/2"	90
5/8"	88
3/4"	86

- Each half of the hinge is formed and welded for maximum strength.
- Hinged with Grade 5 bolt for superior strength.
- The Nylon insert locknut prevents loosening of the hinge.

# BRACES



**General Information**  
 Stock Width: 1 5/8"  
 Fitting Thickness: 1/4"  
 Finish: Painted green or electro-galvanized  
 Hole Diameter: 9/16"  
 Hole Spacing: 13/16" from end, 1 7/8" on center  
 Order By: Part No., Size & finish



## PS 2054 – Corner Connector

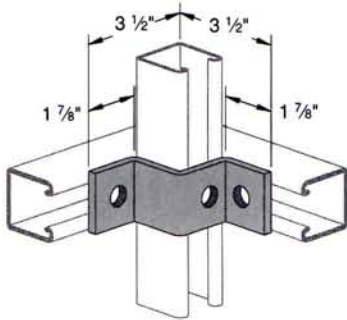

Weight/100 pcs: 66 lbs.

Use With: PS 200, PS 210

## PS 926 – Strut Brace

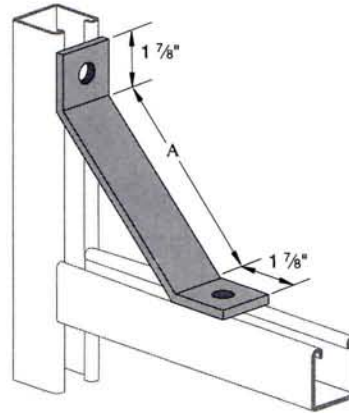

A Size	Wt./ 100 pcs
12	160
18	218
24	280

## PS 810 – Diagonal Tube Brace

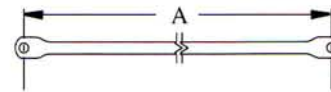
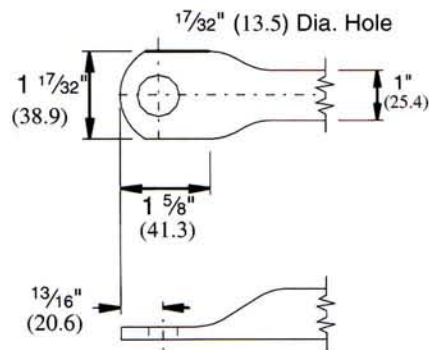
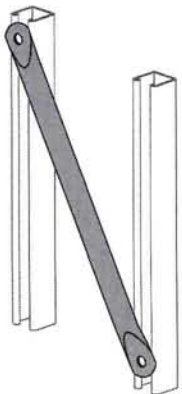

A Size	Wt./ 100 pcs
3'-0"	205
3'-6"	237
4'-0"	270

Note: 30° to 60° angle between the brace and channel is recommended for maximum effect.

Material: 1" dia. electric welded tubing

Stock Thickness: (.075) 14 ga.

## PS 812 – 45° Diagonal Tube Brace

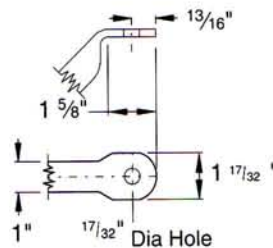
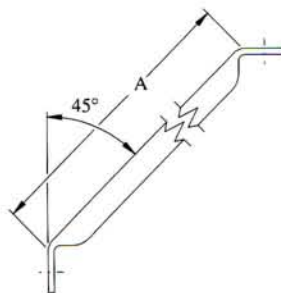

A Size	Wt./ 100 pcs
12"	88
18"	116
24"	149
30"	181
36"	214

Material: 1" dia. electric welded tubing

Stock Thickness: (.075) 14 ga.



General Information  
 Stock Width: 1 5/8"  
 Fitting Thickness: 1/4"  
 Finish: Painted green or electro-galvanized  
 Hole Diameter: 9/16"  
 Hole Spacing: 13/16" from end, 1 7/8" on center  
 Order By: Part No. & finish

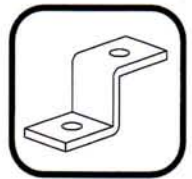

**PS 756 – Zee Support**

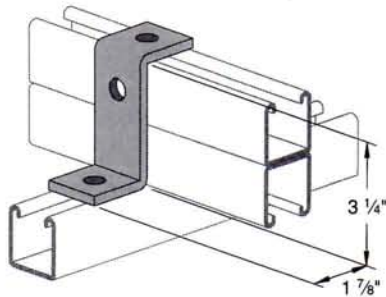

Weight/100 pcs: 70 lbs.  
 Use With: PS 100, PS 200 2T3, PS 210 2T3

**PS 2601 – Zee Support**

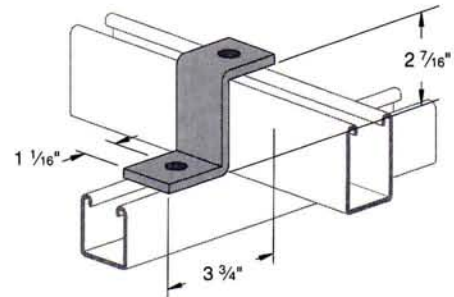

Weight/100 pcs: 67 lbs.  
 Use With: PS 150

**PS 611 – Zee Support**

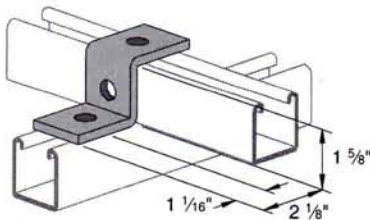

Weight/100 pcs: 55 lbs.  
 Use With: PS 200, PS 210

**PS 711 – Zee Support**

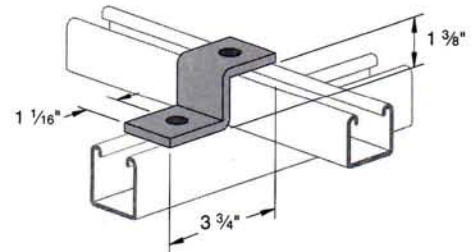

Weight/100 pcs: 53 lbs.  
 Use With: PS 300

**PS 612 – Zee Support**

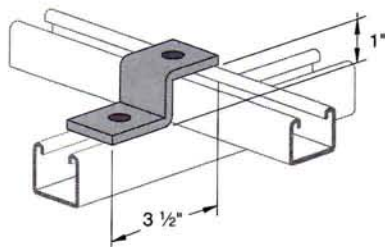

Weight/100 pcs: 47 lbs.  
 Use With: PS 400

**PS 928 – Zee Support**

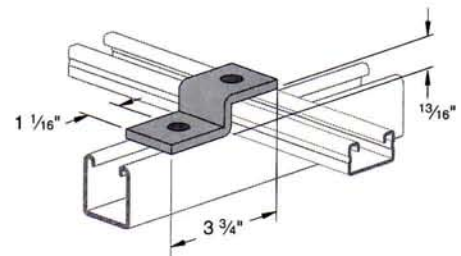

Weight/100 pcs: 47 lbs.  
 Use With: PS 500, PS 520 and PS 560

# ZEE FITTINGS

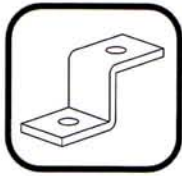

**General Information**  
 Stock Width: 1 5/8"  
 Fitting Thickness: 1/4"  
 Finish: Painted green or electro-galvanized  
 Hole Diameter: 9/16"  
 Hole Spacing: 13/16" from end, 1 7/8" on center  
 Order By: Part No., size & finish



## PS 609 – Two-Hole Offset Plate Connector

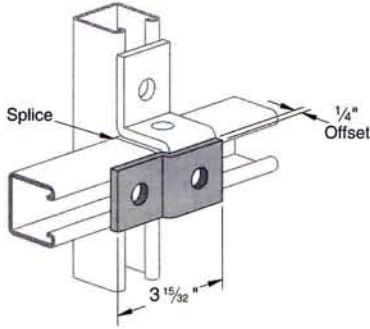

Weight/100 pcs: 38 lbs.

## PS 692 – 1 5/8" Offset Zee Connector

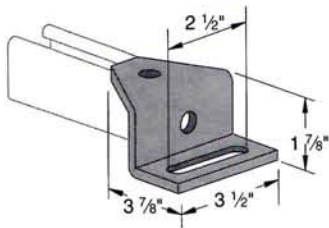

Weight/100 pcs: 102 lbs.

Use With: PS 200, PS 210

## PS 2532 – Shelf Attachment Zee

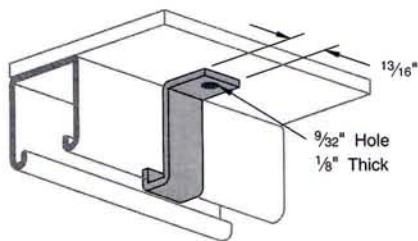

Stock Thickness: 1/8"

Weight/100 pcs: 9 lbs.

Use With: PS 200, PS 210

## PS 647 – 1 7/8" Offset Zee Connector

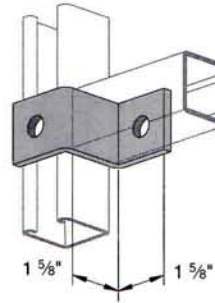

Weight/100 pcs: 55 lbs.

Use With: PS 200, PS 210

## PS 2523 – Offset Adjustable Zee Connector

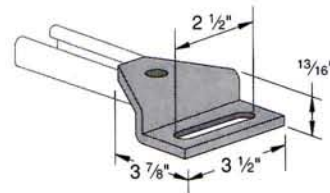

Weight/100 pcs: 70 lbs.

Use With: PS 500, PS 520 and PS 560

## PS 3060 – Offset Connector

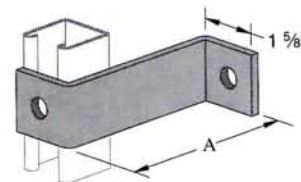

A	Wt./ 100 pcs
4"	81
5"	92
6"	104
7"	115
8"	127





General Information  
 Stock Width: 1 5/8"  
 Fitting Thickness: 1/4"  
 Finish: Painted green or electro-galvanized  
 Hole Diameter: 9/16"  
 Hole Spacing: 13/16" from end, 1 7/8" on center  
 Order By: Part No., Size & finish

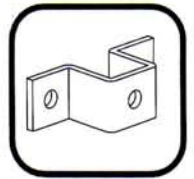

**PS 679 – "U" Support**

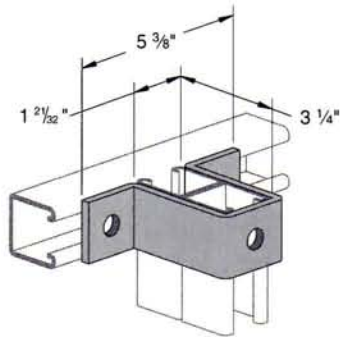

Weight/100 pcs: 128 lbs.  
 Use With: PS 100, PS 200 2T3, PS 210 2T3

**PS 2648 – "U" Support**

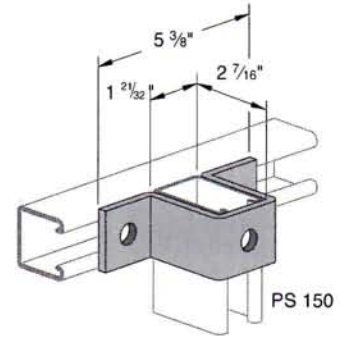

Weight/100 pcs: 108 lbs.  
 Use With: PS 150

**PS 613 – "U" Support**

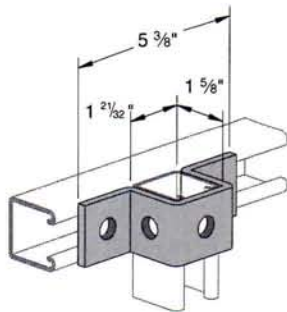

Weight/100 pcs: 88 lbs.  
 Use With: PS 200, PS 210

**PS 2119 – "U" Support**

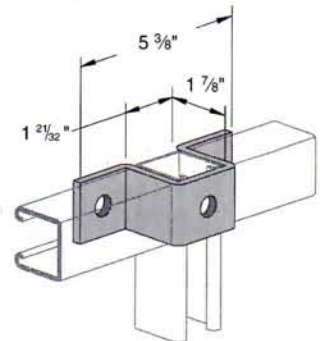

Weight/100 pcs: 95 lbs.  
 Use With: PS 200, PS 210

**PS 687A, PS 687B & PS 687C – Slotted "U" Support**

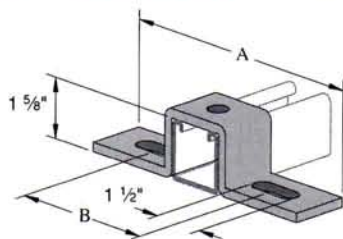

Order No.	'A' Length	'B' Length	Wt./ 100 pcs
PS 687A	7 1/4"	4 1/8"	105
PS 687B	8 1/2"	5 3/8"	120
PS 687C	10 3/8"	7 1/4"	130

Use With: PS 200, PS 210

**PS 710 – "U" Support**

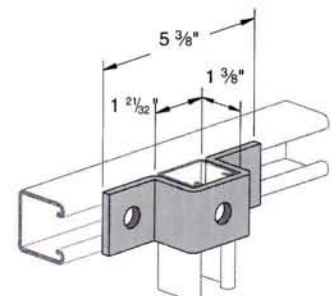

Weight/100 pcs: 84 lbs.  
 Use With: PS 300

# "U" FITTINGS

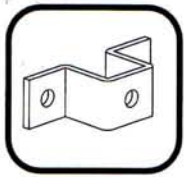

General Information  
 Stock Width: 1 5/8"  
 Fitting Thickness: 1/4"  
 Finish: Painted green or electro-galvanized  
 Hole Diameter: 9/16"  
 Hole Spacing: 13/16" from end, 1 7/8" on center  
 Order By: Part No., Size & finish



## PS 978 – "U" Support

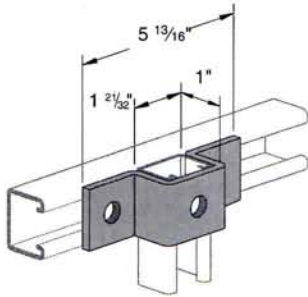

Weight/100 pcs: 71 lbs.  
 Use With: PS 400

## PS 929 – "U" Support

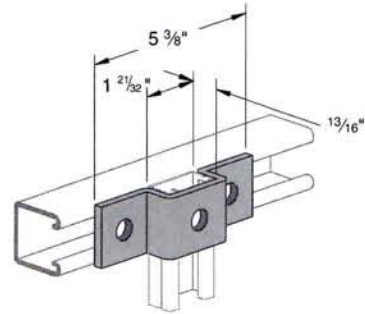

Weight/100 pcs: 71 lbs.  
 Use With: PS 500, PS 520 and PS 560

## PS 721 – "U" Support

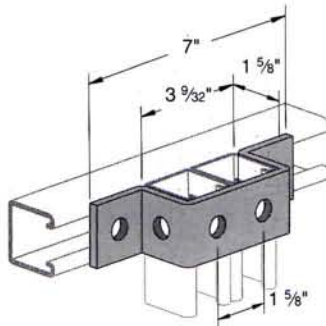

Weight/100 pcs: 105 lbs.  
 Use With: PS 100, PS 200 2T3, PS 210 2T3

## PS 677 – Cup Support for Standard Single Strut

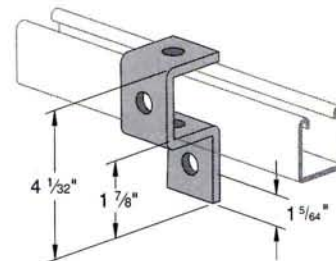

Weight/100 pcs: 76 lbs.  
 Use With: PS 200, PS 210

## PS 678 – Three-Hole "U" Support

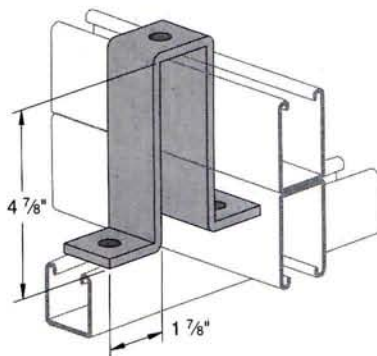

Weight/100 pcs: 197 lbs.  
 Use With: PS 150 2T3

## PS 733 – Six-Hole "U" Support

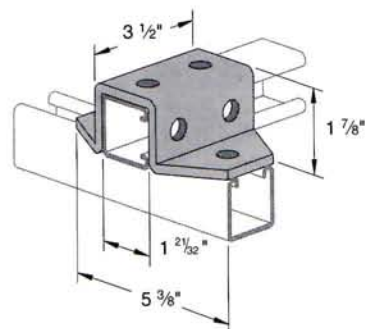

Weight/100 pcs: 171 lbs.  
 Use With: PS 200, PS 210



General Information  
 Stock Width: 1 5/8"  
 Fitting Thickness: 1/4"  
 Finish: Painted green or electro-galvanized  
 Hole Diameter: 9/16"  
 Hole Spacing: 13/16" from end, 1 7/8" on center  
 Order By: Part No., Size & finish

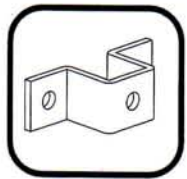

**PS 734** – Eight-Hole "U" Support

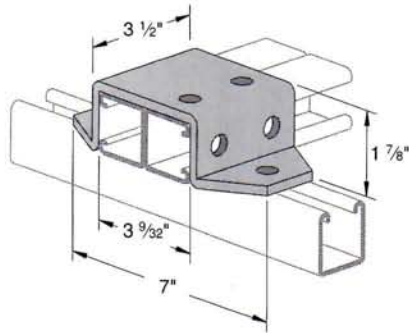

Weight/100 pcs: 209 lbs.  
 Use With: PS 200 2T3

**PS 735** – Eight-Hole "U" Support

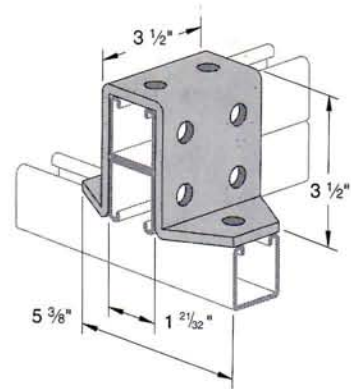

Weight/100 pcs: 257 lbs.  
 Use With: PS 200 2T3

**PS 709** – Three-Hole Offset Plate Connection

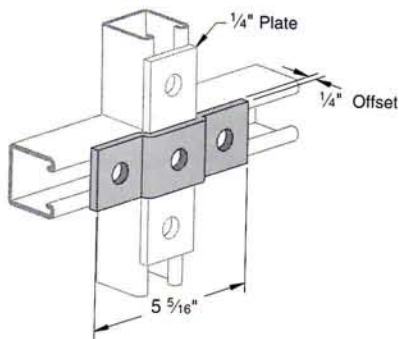

Weight/100 pcs: 58 lbs.

**PS 993** – Inside Clevis Hanger

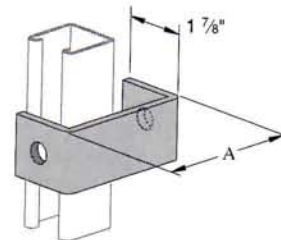

A Size	Wt./ 100 pcs
4"	78
5"	89
6"	101
7"	112
8"	124

# JOINERS

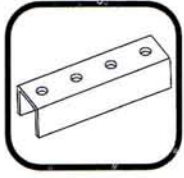

## General Information

Fitting Thickness: 1/4"  
Finish: Painted green or electro-galvanized  
Hole Diameter: 9/16"  
Hole Spacing: 13/16" from end, 1 7/8" on center  
Order By: Part No. & finish



### PS 631 – Two-Hole Splice Clevis

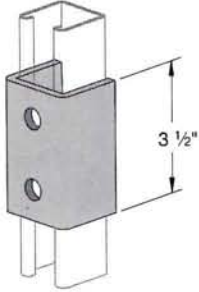

Weight/100 pcs: 128 lbs.  
Use With: PS 200, PS 210

### PS 644 – Two-Hole Splice Clevis

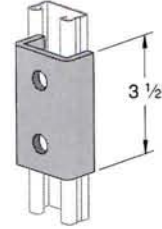

Weight/100 pcs: 85 lbs.  
Use With: PS 500, PS 520 and PS 560

### PS 645 – Three-Hole Splice Clevis

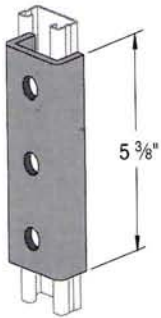

Weight/100 pcs: 130 lbs.  
Use With: PS 500, PS 520 and PS 560

### PS 646 – Four-Hole Splice Clevis

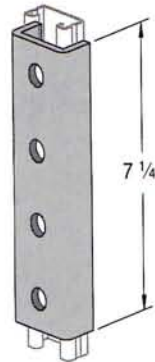

Weight/100 pcs: 176 lbs.  
Use With: PS 500, PS 520 and PS 560

### PS 616 – Four-Hole Splice Clevis

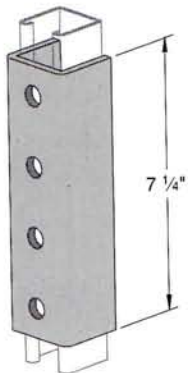

Weight/100 pcs: 265 lbs.  
Use With: PS 200, PS 210

### PS 804 – Slotted Joiner

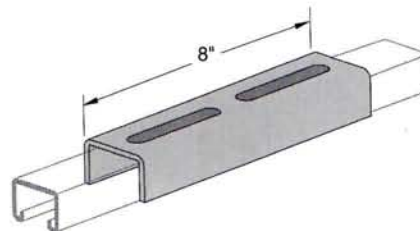

Stock Thickness: (.105)  
Weight/100 pcs: 80 lbs.  
Use With: PS 400S, PS 500S, PS 520S and PS 560S  
NOTE: Order PS 6072 screws & PS 6108 nuts separately.



**General Information**

Fitting Thickness: 1/4"  
 Finish: Painted green or electro-galvanized  
 Hole Diameter: 9/16"  
 Hole Spacing: 13/16" from end, 1 7/8" on center  
 Order By: Part No. & finish

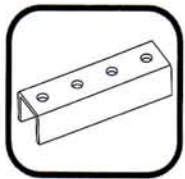

**PS 704 – Slotted Joiner**

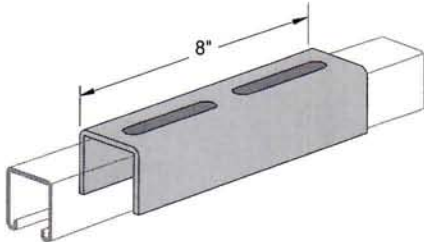

Stock Thickness: (.105)  
 Weight/100 pcs: 197 lbs.  
 Use With: PS 200S, PS 210S  
 NOTE: Order PS 6072 screws & PS 6108 nuts separately.

**PS 1004 – Slotted Joiner**

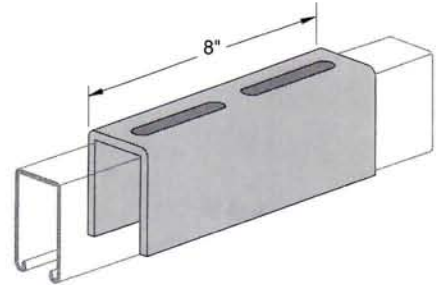

Stock Thickness: (.105)  
 Weight/100 pcs: 140 lbs.  
 Use With: PS 150S  
 NOTE: Order PS 6072 screws & PS 6108 nuts separately.

**PS 629 – Three-Hole Splice Clevis**

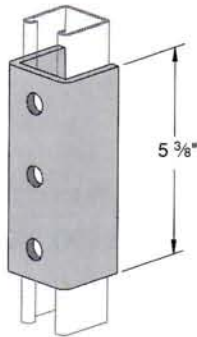

Weight/100 pcs: 197 lbs.  
 Use With: PS 200 and PS 210

# WING FITTINGS

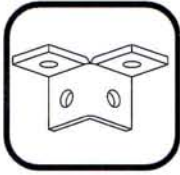

## General Information

Fitting Thickness: 1/4"  
 Finish: Painted green or electro-galvanized  
 Hole Diameter: 9/16"  
 Hole Spacing: 13/16" from end, 1 7/8" on center  
 Order By: Part No. & finish



### PS 922 R OR L – Three-Hole Corner Connector

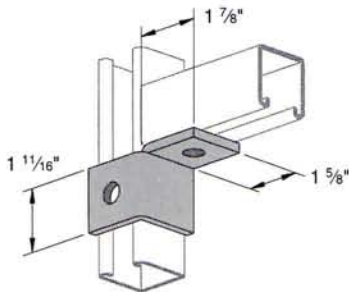

Weight/100 pcs: 60 lbs.

NOTE: Specify R (Right) or L (Left) – Right Hand illustrated

### PS 2117 R OR L – Wrap-Around Corner Connector

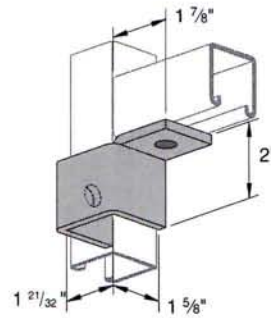

Weight/100 pcs: 75 lbs.

NOTE: Specify R (Right) or L (Left) – Right Hand illustrated

### PS 2128 R OR L – Six-Hole Corner Connector

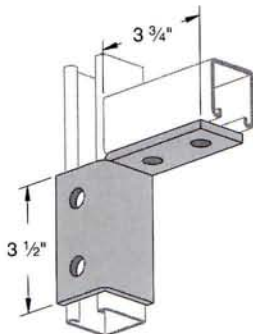

Weight/100 pcs: 119 lbs.

NOTE: Specify R (Right) or L (Left) – Right Hand illustrated

### PS 2129 R OR L – Single Corner Gussetted Connection

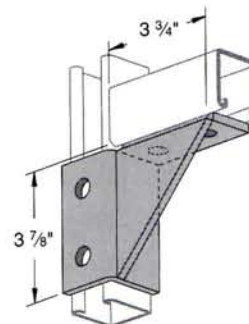

Weight/100 pcs: 176 lbs.

NOTE: Specify R (Right) or L (Left) – Right Hand illustrated



**General Information**

Fitting Thickness: 1/4"  
 Finish: Painted green or electro-galvanized  
 Hole Diameter: 9/16"  
 Hole Spacing: 13/16" from end, 1 7/8" on center  
 Order By: Part No. & finish

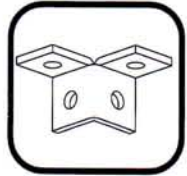

**PS 665** – Four-Hole Double Corner Connector

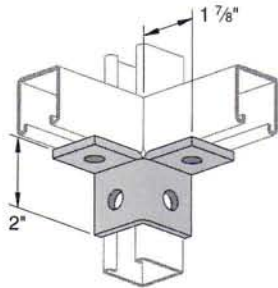

Weight/100 pcs: 76 lbs.

**PS 667** – Eight-Hole Double Corner Connector

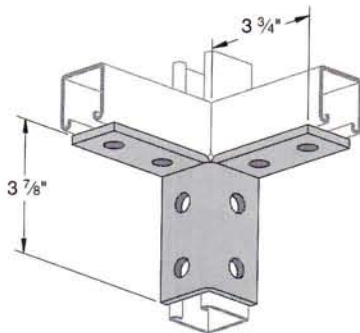

Weight/100 pcs: 155 lbs.

**PS 666** – Six-Hole Double Corner Connector

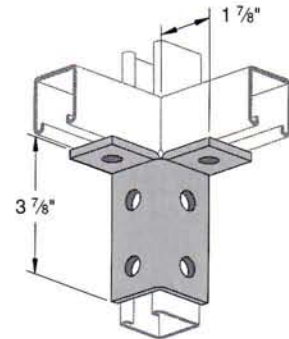

Weight/100 pcs: 115 lbs.

**PS 943** – Eight-Hole Gussetted Double Corner Connector

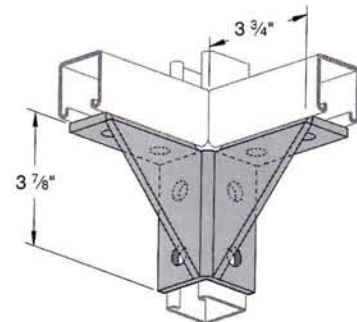

Weight/100 pcs: 217 lbs.

# WING FITTINGS

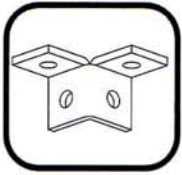

## General Information

Fitting Thickness: 1/4"  
 Finish: Painted green or electro-galvanized  
 Hole Diameter: 9/16"  
 Hole Spacing: 13/16" from end, 1 7/8" on center  
 Order By: Part No. & finish



### PS 923 – Five-Hole Double Wing Connector

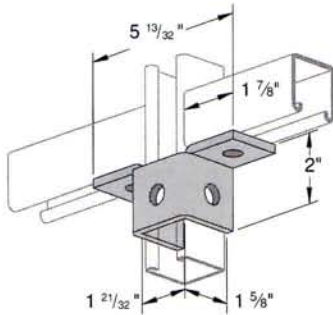

Weight/100 pcs: 93 lbs.

### PS 913 – Ten-Hole Double Wing Connector

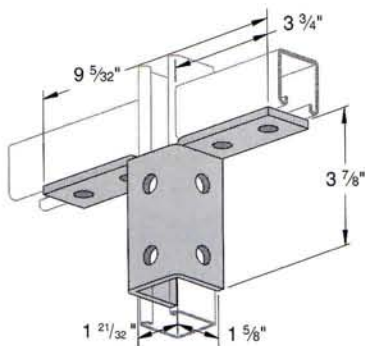

Weight/100 pcs: 193 lbs.

### PS 821 – Eight-Hole Double Wing Connector

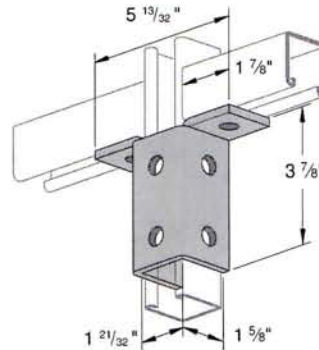

Weight/100 pcs: 150 lbs.

### PS 945 – Ten-Hole Gussetted Double Wing Connector

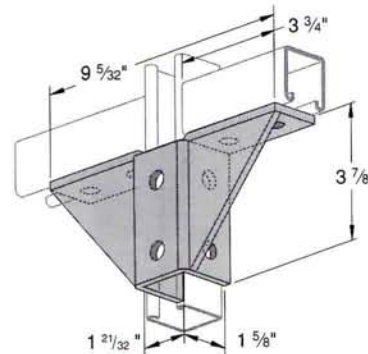

Weight/100 pcs: 274 lbs.





**General Information**

Fitting Thickness: 1/4"  
 Finish: Painted green or electro-galvanized  
 Hole Diameter: 9/16"  
 Hole Spacing: 13/16" from end, 1 7/8" on center  
 Order By: Part No. & finish

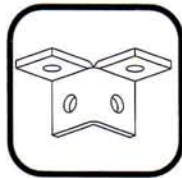

**PS 668 – Six-Hole Triple Wing Connector**

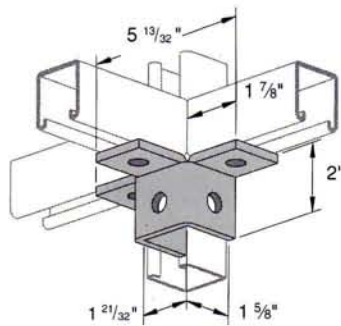

Weight/100 pcs: 113 lbs.

**PS 669 – Twelve-Hole Triple Wing Connector**

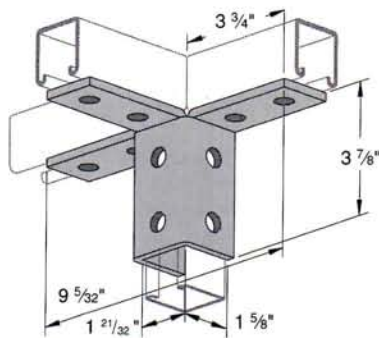

Weight/100 pcs: 230 lbs.

**PS 670 – Nine-Hole Triple Wing Connector**

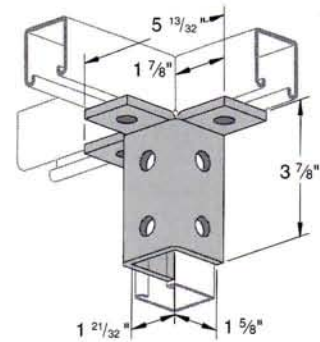

Weight/100 pcs: 177 lbs.

**PS 2514 – Eight-Hole Gussetted Double Corner Connector**

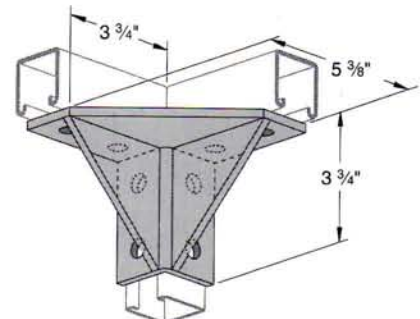

Weight/100 pcs: 315 lbs.

# POST BASE

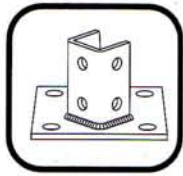

## General Information

Fitting Thickness: 1/4"  
 Finish: Painted green or electro-galvanized  
 Hole Diameter: 9/16"  
 Hole Spacing: 13/16" from end, 1 7/8" on center  
 Order By: Part No. & finish



### PS 3013, PS 3013 SQ – Post Base

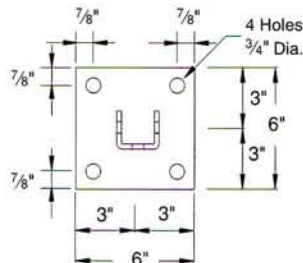
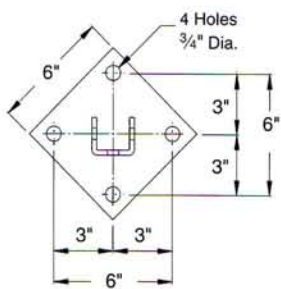
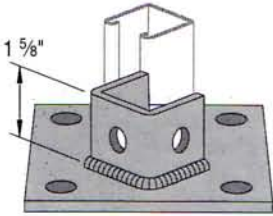

PS 3013 SQ Version

Weight/100 pcs: 307 lbs.

### PS 3025, PS 3025 FL – Post Base

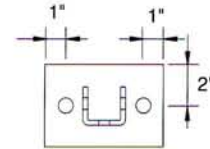
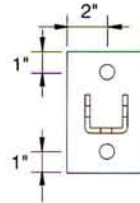
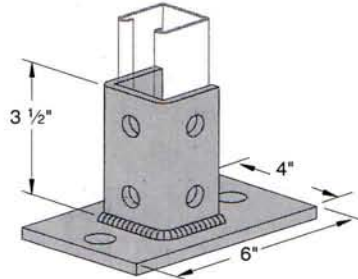

Weight/100 pcs: 358 lbs.

### PS 3033, PS 3033 SQ – Post Base

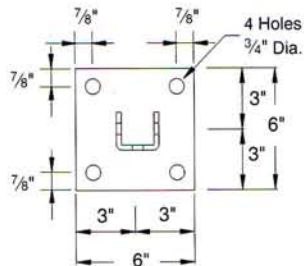
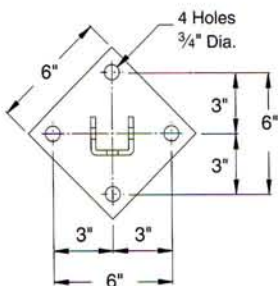
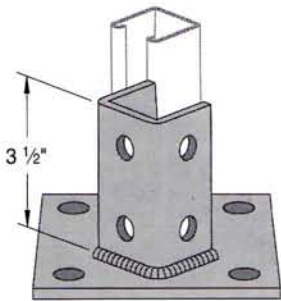

PS 3033 SQ Version

Weight/100 pcs: 373 lbs.

### PS 3040 – Post Base

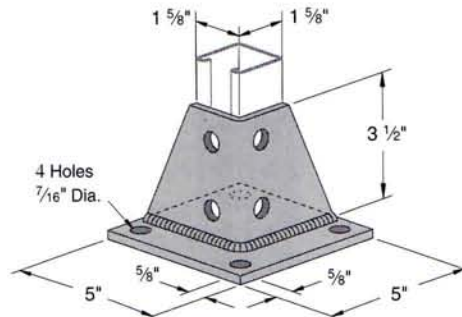

Weight/100 pcs: 297 lbs.



**General Information**

Fitting Thickness: 1/4"  
 Finish: Painted green or electro-galvanized  
 Hole Diameter: 9/16"  
 Hole Spacing: 13/16" from end, 1 7/8" on center  
 Order By: Part No. & finish

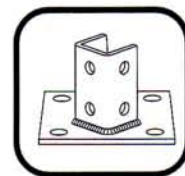

**PS 3041 – Double-Column Post Base**

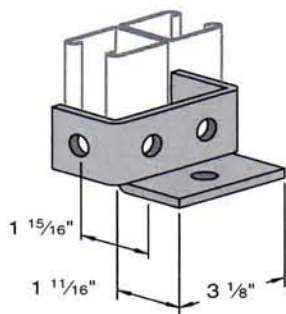

Weight/100 pcs: 116 lbs  
 Use With: PS 100, PS 200 2T3, and PS 210 2T3.

**PS 2064 – Double-Column Post Base**

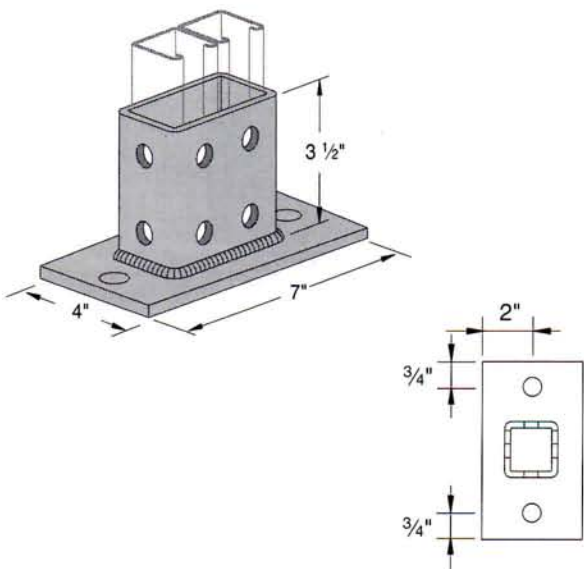

Weight/100 pcs: 311 lbs.  
 Use With: PS 100, PS 200 2T2, PS 200 2T3, PS 200 2T4 and PS 200 2T5

**PS 3029 – Double-Column Post Base**

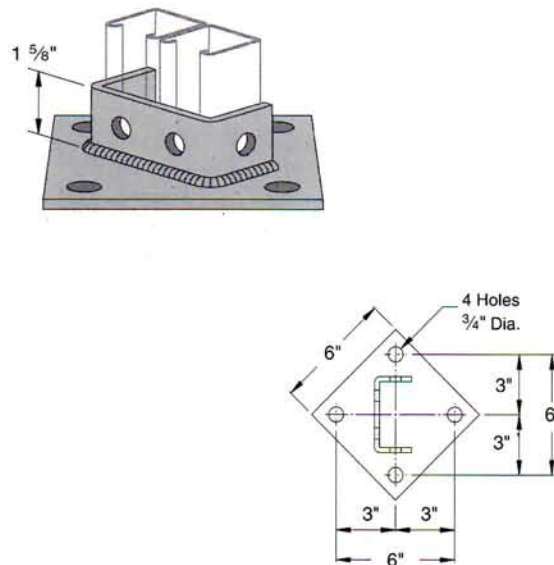

Weight/100 pcs: 325 lbs.  
 Use With: PS 100, PS 200 2T3, PS 210 2T3

**PS 3064 – Double-Column Post Base**

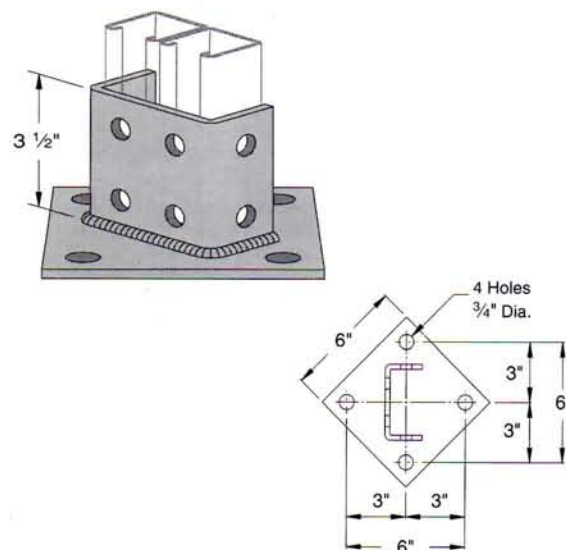

Weight/100 pcs: 408 lbs.  
 Use With: PS 100, PS 200 2T3, PS 200 2T4 and PS 200 2T5

# TROLLEYS

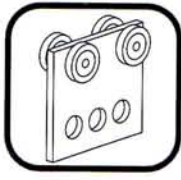

## General Information

Fitting Thickness: 1/4"  
 Finish: Painted green or electro-galvanized  
 Hole Diameter: 9/16"  
 Order By: Part No. & finish



### PS 2521 – Two-Wheel Trolley

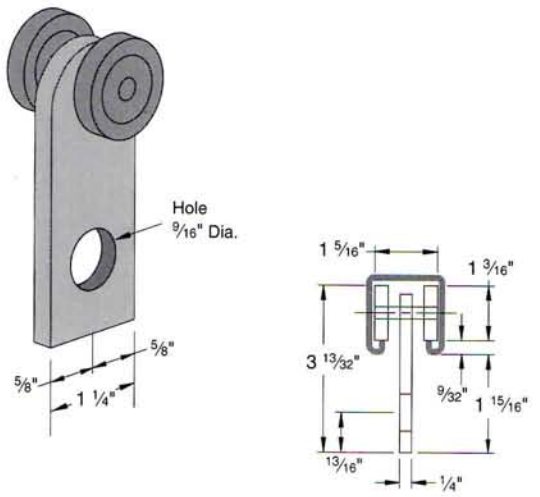

Material: Carbon Steel Wheels have stainless steel ball bearings  
 Finish: Electro-Galvanized  
 Weight/100 pcs: 46 lbs.  
 Use With: PS 200  
 Load Rating: 300 lbs.

### PS 2522 – Four-Wheel Trolley

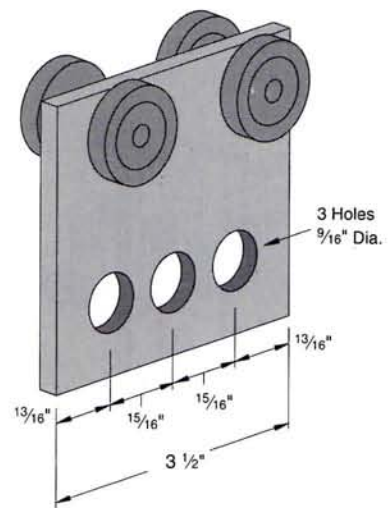

Material: Carbon Steel Wheels have stainless steel ball bearings  
 Finish: Electro-Galvanized  
 Weight/100 pcs: 110 lbs.  
 Use With: PS 200  
 Load Rating: 600 lbs.

### PS 2528 – Trolley Beam Standard Support

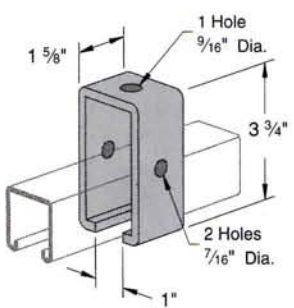

Weight/100 pcs: 102 lbs.  
 Use With: PS 200, PS 210  
 Load Rating: 600 lbs.

### PS 2528 - 1 – Trolley Beam Heavy Support

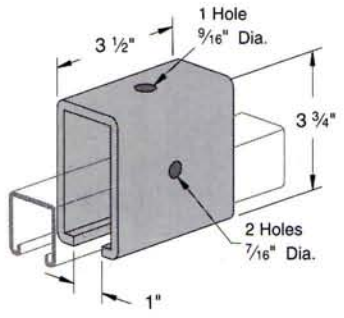

Weight/100 pcs: 220 lbs.  
 Use With: PS 200, PS 210  
 Load Rating: 2500 lbs.



General Information

Fitting Thickness: 1/4"  
 Finish: Painted green or electro-galvanized  
 Hole Diameter: 9/16"  
 Order By: Part No. & finish

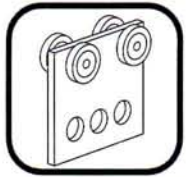

**PS 2524** – Two-Bearing Light Duty Trolley

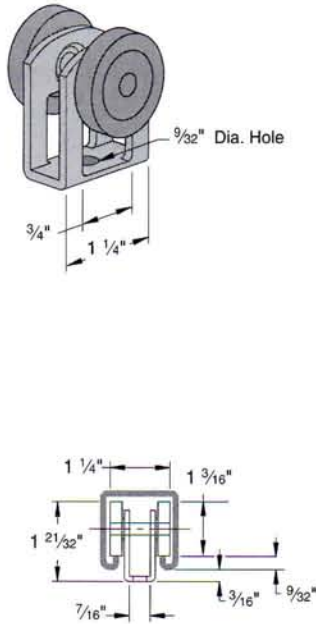

Weight/100 pcs: 21 lbs.  
 Load Rating: 50 lbs.

**PS 2525** – Four-Bearing Light Duty Trolley

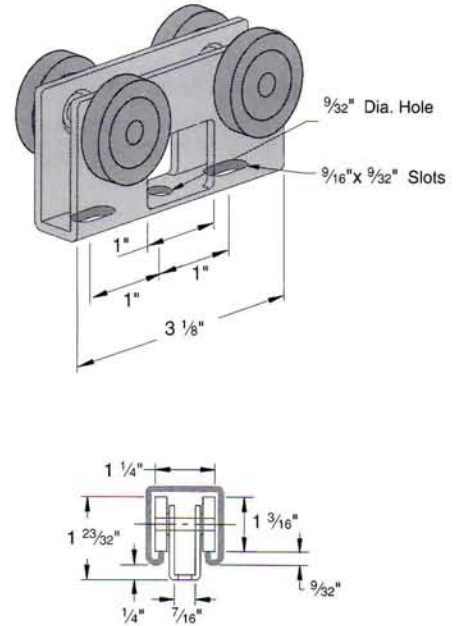

Weight/100 pcs: 55 lbs.  
 Load Rating: 100 lbs.



# PIPE & CONDUIT CLAMPS



## Materials & Manufacturing Specifications

### **MATERIAL:**

Power-Strut pipe, conduit and O.D. tubing clamps are made on punch press dies from hot rolled, pickled and oiled steel which conforms to the ASTM A-366, A-570, A-575 and A-576 standards.

Select sizes of O.D. tubing clamps are available in stainless steel or aluminum.

### **STANDARD FINISH:**

All steel clamps are electro-galvanized. Select sizes of O.D. tubing clamps are available in copper plated finish. PVC coatings are available upon special request.

### **ORDERING INFORMATION:**

When ordering, add the length or size and finish to the part number. See page 5 for finish abbreviations and an example.

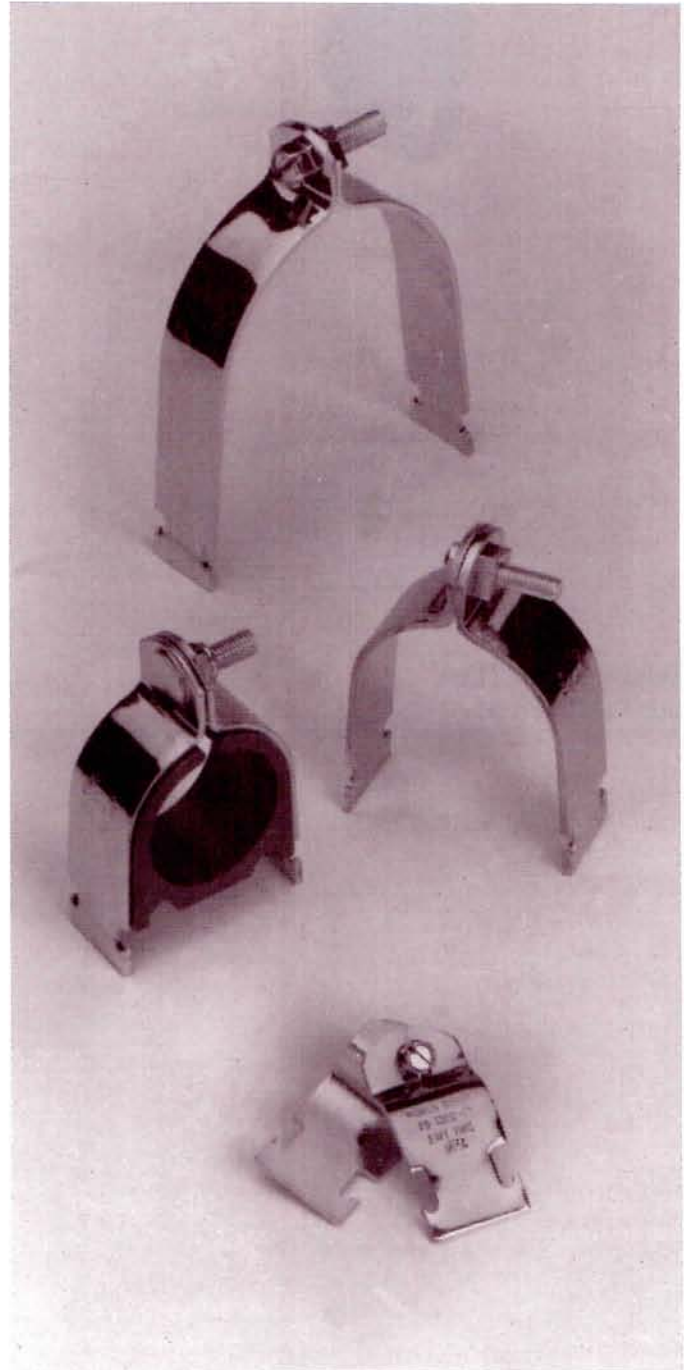



**General Information**

Finish: Electro-galvanized  
Order By: Part no. & Size



**PS 1000 – EMT Conduit Clamp**

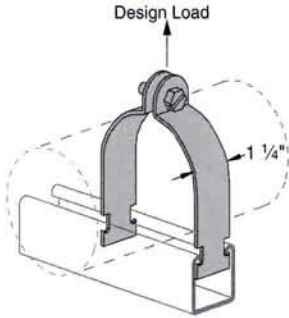

EMT Size	Stock Thickness	Hanging Load Rating/lbs.	Wt./ 100 pcs
1/2"	.060	400	11
3/4"	.060	400	12
1"	.075	600	15
1 1/4"	.075	600	18
1 1/2"	.105	800	29
2"	.105	800	33

**PS 1300 – Universal Pipe Clamp for EMT, IMC & GRC**

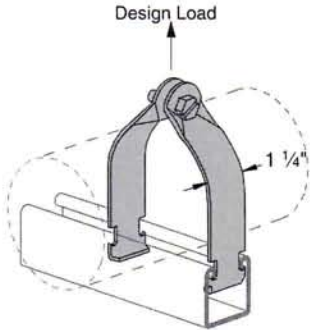

Nom Size	Fits O.D.	Stock Thickness	Hanging Load Rating/lbs.	Wt./ 100 pcs
1/2"	.706-.840	.060	250	10
3/4"	.922-1.050	.075	400	11
1"	1.163-1.315	.075	400	12
1 1/4"	1.510-1.660	.075	400	18
1 1/2"	1.740-1.900	.105	500	20
2"	2.197-2.375	.105	500	22

**PS 1100, PS 1116 , PS 1117 – Standard Pipe Clamp (GRC and IMC)**

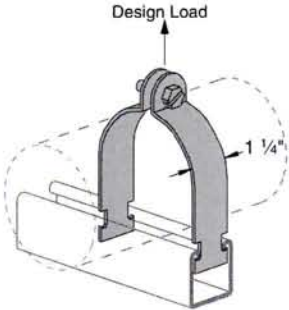

Material and finish are specified as:

- 1100 ALM**.. Alum. clamp, EG fasteners
- 1100 HDG**.. HDG Clamp, Stainless Steel fasteners
- 1116** ..... Alum. clamp and fasteners
- 1117** ..... Alum. clamp, Stainless Steel fasteners
- 1100SS** ..... Stainless Steel clamp and fasteners

Pipe Size	Stock Thickness	Hanging Load Rating/lbs.	Wt./ 100 pcs
3/8"	.060	400	10
1/2"	.060	400	11
3/4"	.075	600	15
1"	.075	600	17
1 1/4"	.075	600	19
1 1/2"	.105	800	29
2"	.105	800	34
2 1/2"	.105	800	40
3"	.105	800	47
3 1/2"	.125	1000	62
4"	.125	1000	67
5"	.125	1000	80
6"	.135	1000	102
8"	.135	1000	130
10"	.135	1000	143
12"	.135	1000	174

# PIPE & CONDUIT CLAMPS



General Information

Finish: Electro-galvanized  
Order By: Part no. & Size



## PS 1200 – O.D. Tubing Clamp

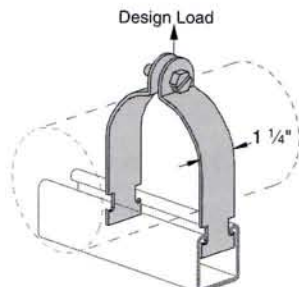

O.D. Size	Stock Thickness	Hanging Load Rating/lbs.	Wt./ 100 pcs	Other Finishes Available
1/4"	.060	400	8	
3/8"	.060	400	8	CPLT
1/2"	.060	400	9	CPLT
5/8"	.060	400	10	CPLT
3/4"	.060	400	11	
7/8"	.060	400	12	CPLT
1"	.075	600	14	
1 1/8"	.075	600	15	SS CPLT
1 1/4"	.075	600	16	SS
1 3/8"	.075	600	17	SS CPLT
1 1/2"	.075	600	18	SS
1 5/8"	.075	600	19	SS CPLT
1 3/4"	.105	800	29	SS
1 7/8"	.105	800	28	SS
2"	.105	800	31	SS
2 1/8"	.105	800	32	SS CPLT
2 1/4"	.105	800	33	SS
2 3/8"	.105	800	34	SS
2 1/2"	.105	800	35	SS
2 5/8"	.105	800	37	SS CPLT
2 3/4"	.105	800	38	SS
2 7/8"	.105	800	40	SS
3"	.105	800	41	SS
3 1/8"	.105	800	43	SS CPLT
3 1/4"	.105	800	45	SS
3 3/8"	.105	800	46	SS
3 1/2"	.105	1000	47	SS
3 5/8"	.125	1000	56	SS CPLT
3 3/4"	.125	1000	58	SS
3 7/8"	.125	1000	60	SS
4"	.125	1000	62	SS
4 1/8"	.125	1000	62	SS CPLT
4 1/4"	.125	1000	64	SS
4 3/8"	.125	1000	66	SS
4 1/2"	.125	1000	67	SS

O.D. Size	Stock Thickness	Hanging Load Rating/lbs.	Wt./ 100 pcs
4 5/8"	.125	1000	70
4 3/4"	.125	1000	72
4 7/8"	.125	1000	73
5"	.125	1000	74
5 1/8"	.125	1000	76
5 1/4"	.125	1000	77
5 3/8"	.125	1000	78
5 1/2"	.125	1000	79
5 5/8"	.135	1000	88
5 3/4"	.135	1000	90
5 7/8"	.135	1000	92
6"	.135	1000	94
6 1/8"	.135	1000	96
6 1/4"	.135	1000	98
6 3/8"	.135	1000	99
6 1/2"	.135	1000	100
6 5/8"	.135	1000	102
6 3/4"	.135	1000	104
6 7/8"	.135	1000	106
7"	.135	1000	108
7 1/8"	.135	1000	110
7 1/4"	.135	1000	112
7 3/8"	.135	1000	114
7 1/2"	.135	1000	116
7 5/8"	.135	1000	117
7 3/4"	.135	1000	119
7 7/8"	.135	1000	121
8"	.135	1000	123
8 1/8"	.135	1000	125
8 1/4"	.135	1000	126
8 3/8"	.135	1000	128
8 1/2"	.135	1000	129
8 5/8"	.135	1000	130

Please contact factory for sizes not shown.

NOTE: SS - Stainless Steel  
CPLT - Copper Plated





**General Information**

Finish: Electro-galvanized  
Order By: Part no. & Size



**PS 3138 – Parallel Run Pipe Clamp**

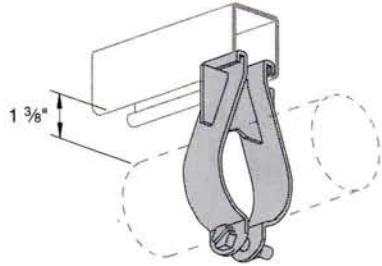

Pipe Size	Load Rating	Wt./ 100 pcs
3/8"	300	27
1/2"	300	29
3/4"	300	30
1"	400	31
1 1/4"	400	38
1 1/2"	500	40
2"	500	47
2 1/2"	500	66
3"	500	78
3 1/2"	500	87
4"	500	90

**PS 3126 – One-Piece Pipe Strap**

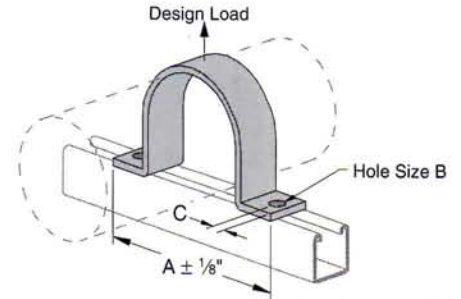

Pipe Size	A	B	C	Design Load	Wt./ 100 pcs
1/2"	2 7/16	1/8	5/16	500	23
3/4"	3 1/16	1/8	5/16	500	26
1"	3 1/2	1/8	5/16	500	31
1 1/4"	3 13/16	1/8	5/16	500	35
1 1/2"	3 15/16	1/8	5/16	500	39
2"	5 11/16	1/4	7/16	1000	94
2 1/2"	6 3/16	1/4	7/16	1000	114
3"	6 11/16	1/4	7/16	1000	133
3 1/2"	7 13/16	1/4	7/16	1000	152
4"	8	1/4	7/16	1000	176
5"	9	1/4	7/16	1000	198
6"	10 1/8	1/4	7/16	1000	225

**PS 1450 – One-Hole Clamp for O.D. Tubing**

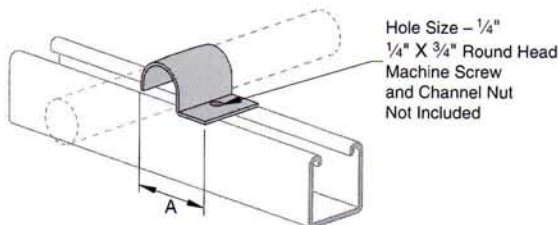

O.D. Size	A	Wt./ 100 pcs
1/4"	1 1/16"	4
3/8"	1 1/8"	5
1/2"	1 3/16"	6
5/8"	1 1/4"	8
3/4"	1 5/16"	9
7/8"	1 3/8"	10
1"	1 7/16"	11

**PS 3792 – Power-Wrap™**

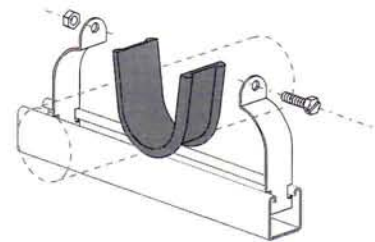

Material: EPDM  
Stock Thickness: 1/8"  
Stock Length: 25 ft./box, field cut to length as needed  
Weight/100 boxes: 253 lbs.  
Service Temp: -70° to 350° F

# PIPE & CONDUIT CLAMPS



## General Information

Finish: Electro-galvanized  
Order By: Part no. & Size



## PS 1400 – Clamps With Cushions For Pipes, Tubes, And Hoses

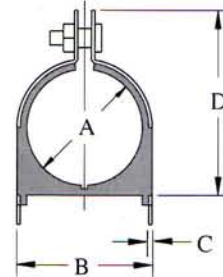
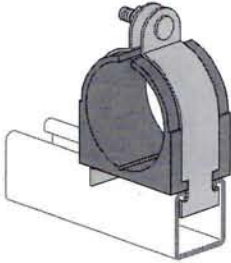

- **Application** – The clamps and cushions are engineered to accommodate a range of O.D. sizes. The clamp assembly fits into Power-Strut channel and is securely fastened in place with a wrench, screwdriver, or pliers. The clamping system allows for addition or replacement of tubes without disturbing the surrounding area.

- **Advantages** – The thermoplastic rubber cushion eliminates metal to metal contact, preventing galvanic corrosion. The thermoplastic rubber cushion dampens vibrations and deafens noise from equipment hammering and hydraulic surges. The thermoplastic rubber elasticity allows servicing temperatures from -60°F to 275°F.

- **PS 1400 Assembly** – Clamp-Electro-galvanized steel which conforms to ASTM A-366 or A-570. Cushion-Thermoplastic rubber. Fastener captive machine screw with nylon insert locknut.

A Size O.D.	Fits Copper Tube (nom.)	B	C	D	Wt./ 100 pcs
1/4"	1/8"	1 1/16"	.060	1/2"	12
3/8"	1/4"	1 1/4"	.060	5/8"	13
1/2"	3/8"	1 3/8"	.060	3/4"	13
5/8"	1/2"	1 1/2"	.060	7/8"	15
3/4"	5/8"	1 3/4"	.075	1 1/8"	21
7/8"	3/4"	1 7/8"	.075	1 1/4"	22
1 1/8"	1"	2 1/16"	.075	1 1/2"	29
1 3/8"	1 1/4"	2 7/16"	.075	1 3/4"	33
1 5/8"	1 1/2"	3"	.105	2 1/4"	42
2 1/8"	2"	3 3/8"	.105	2 3/4"	50
2 5/8"	2 1/2"	3 7/8"	.105	3 1/4"	62
3 1/8"	3"	4 5/16"	.105	3 3/4"	66
4 1/8"	4"	5 1/2"	.125	4 3/4"	88

## PS 3101 thru PS 3115 – One-Piece cable & Conduit Clamp

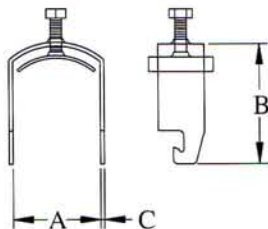
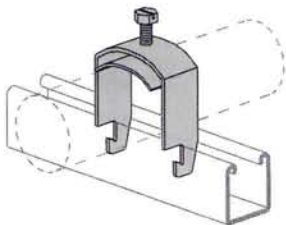

Part No.	Max O.D. Size	A	B	C	Weight/100 pcs
PS 3101	3/8"	7/16"	1 5/8"	14	6
PS 3102	1/2"	9/16"	1 3/4"	14	7
PS 3103	3/4"	13/16"	2"	14	12
PS 3104	1"	1 1/16"	2 1/4"	14	15
PS 3105	1 1/4"	1 5/16"	2 1/2"	14	19
PS 3106	1 1/2"	1 9/16"	2 3/4"	14	20
PS 3107	1 3/4"	1 13/16"	3"	12	25
PS 3108	2"	2 1/16"	3 1/4"	12	35
PS 3109	2 3/8"	2 7/16"	3 5/8"	12	41
PS 3110	2 3/4"	2 13/16"	4"	12	60
PS 3111	3 1/4"	3 5/16"	4 1/2"	12	74
PS 3112	3 3/4"	3 13/16"	5"	12	91
PS 3113	4"	4 1/16"	5 1/4"	12	100
PS 3114	4 3/8"	4 7/16"	5 5/8"	12	115
PS 3115	4 3/4"	4 13/16"	6"	12	125



## BRACKETS



### Materials & Manufacturing Specifications

**MATERIAL:**

Power-Strut brackets are made by punch press and roll form operations from hot rolled, mild steel.

**STANDARD FINISH:**

Power-Strut brackets are available in painted green or electro-galvanized finishes.

**ORDERING INFORMATION:**

When ordering, add the length or size and finish to the part number. See page 5 for finish abbreviations and an example.

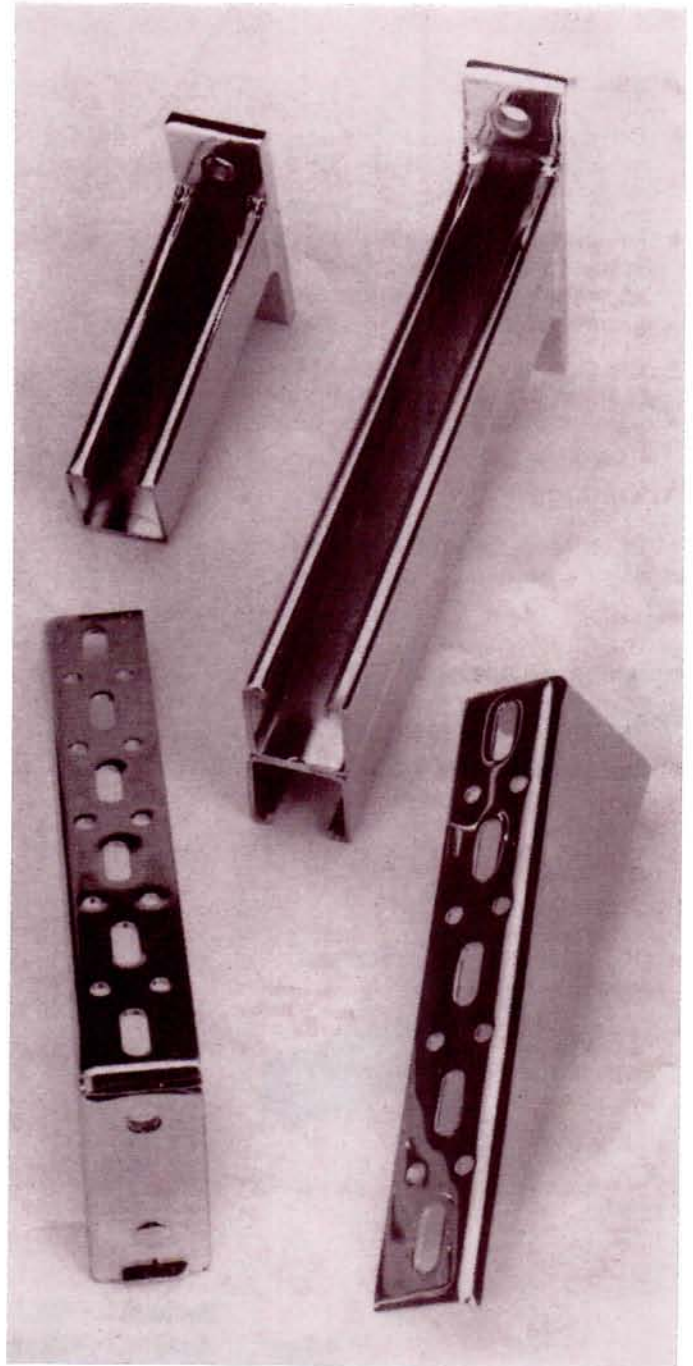

# BRACKETS

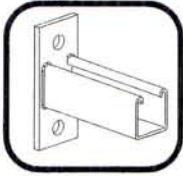

## General Information

Hole Diameter: 9/16"  
 Finish: Painted green or Electro-galvanized  
 Order By: No., Size & Finish



### PS 626 – Pipe Stop

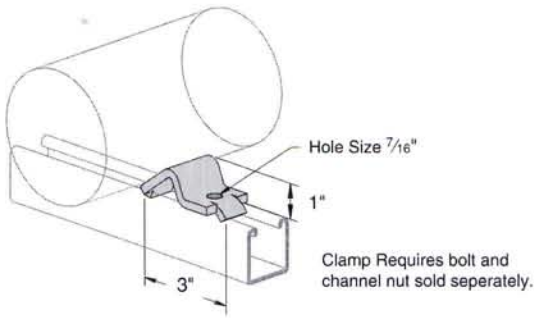

NOTE: For use with 2" to 8" Pipe  
 Weight/100 pcs: 40 lbs.

### PS 661 – Wrap-Around Channel Bracket

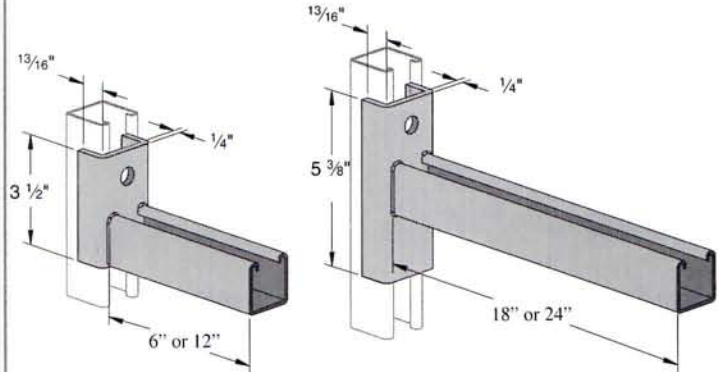

Size	Uniform Load*	Wt./ 100 pcs
6"	1600	191
12"	800	292
18"	600	436
24"	450	536

NOTE: Standard as illustrated  
 (Can be manufactured with continuous slot down.)

\*Mounted on 12 Ga. Channel

### PS 808 – Interlocking Channel Bracket

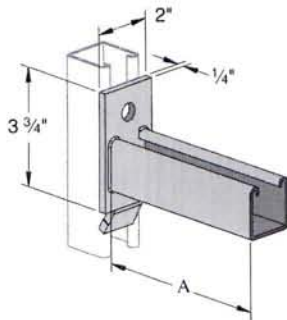

A Size	Uniform Load*	Wt./ 100 pcs
6"	1200	161
12"	600	261
18"	400	361
24"	300	461

NOTE: Standard as illustrated  
 (Can be manufactured with continuous slot down.)

\*Mounted on 12 Ga. Channel

### PS 651 – Reversible Channel Bracket

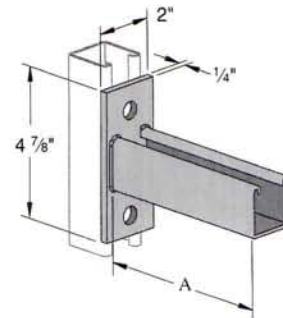

A Size	Uniform Load*	Wt./ 100 pcs
6"	1200	185
12"	600	293
18"	400	401
24"	300	509

\*Mounted on 12 Ga. Channel



**General Information**

Finish: Painted green or Electro-galvanized  
Order By: No., Size & Finish

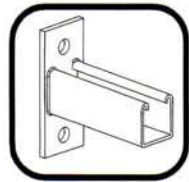

**PS 809 – Double Channel Bracket**

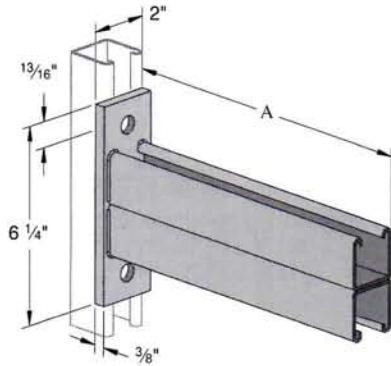

A Size	Uniform Load*	Wt./ 100 pcs
12"	2000	502
18"	1300	692
24"	1000	882
30"	800	1072
36"	650	1262

\*Mounted on 12 Ga. Channel

**PS 708 – Single Channel Bracket Support**

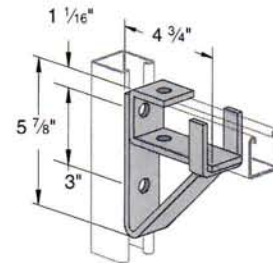

Weight/100 pcs: 235 lbs.

Use With: PS 200, PS 210, PS 500 2T3

Design Moment on Upright Channel:

- 16 ga. channel 3,200 in.-lbs.,
- 14 ga. channel 4,400 in.-lbs.
- 12 ga. channel 5,100 in.-lbs.

NOTE: Moment is for fitting only.  
Channel may determine overall capacity

**PS 3164 – Double Channel Bracket Support**

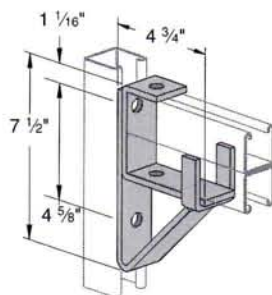

Weight/100 pcs: 273 lbs.

Use With: PS 200 2T3, PS 210 2T3

Design Moment on Upright Channel:

- 16 ga. channel 6,500 in.-lbs.
- 14 ga. channel 9,100 in.-lbs.
- 12 ga. channel 13,000 in.-lbs.

NOTE: Moment is for fitting only.  
Channel may determine overall capacity

**PS 732 – Shelf Bracket**

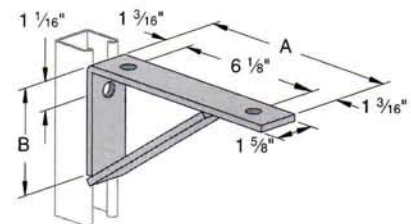

Pipe Size	A	B	Uniform Load*	Wt./ 100 pcs
8"	8 1/2	4	800	168
10"	10 1/2	4	800	202
12"	12 1/2	6	900	258
14"	14 1/2	6	900	292
16"	16 1/2	6	1200	381
18"	18 1/2	6	1200	416
20"	20 1/2	6	1000	461

\*Mounted on 12 ga. channel

# BRACKETS



## General Information

Finish: Painted green or Electro-galvanized  
Order By: No., Size & Finish



### PS 838 R OR L – Shelf Bracket

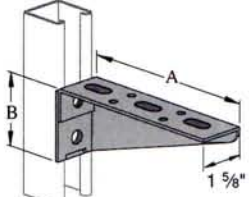

Right Hand Illustrated

A Size	B	Uniform Load Rating*	Wt./ 100 pcs
6"	2 15/16"	275	58
8"	2 15/16"	275	83
10"	2 15/16"	275	114
12"	3 7/16"	275	149
14"	3 15/16"	275	174
16"	4 7/16"	275	225
18"	4 15/16"	275	255
20"	5 7/16"	275	295
22"	5 15/16"	275	361
24"	6 7/16"	275	396
26"	6 15/16"	275	456
28"	7 7/16"	275	479
30"	7 15/16"	275	544

Stock Thickness: .105

NOTE: Specify R (Right) or L (Left) when ordering.

\* Mounted on 12 ga. channel.

### PS 3282 – Cable Tray Strut Bracket

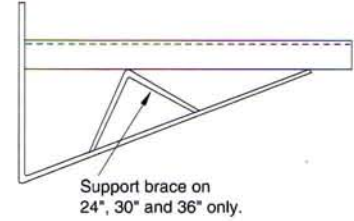
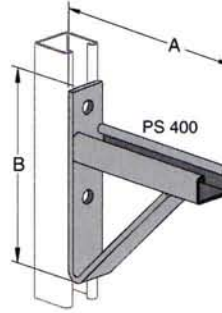

NOTE: PS 400 channel welded to 1/4" stock

A	B	Uniform Load*	wt./ 100 pcs
12"	8 3/4"	1900	388
18"	8 3/4"	1000	506
24"	8 3/4"	1000	763
30"	11 1/4"	900	1012
36"	11 1/4"	800	1083

\* Mounted on 12 ga. channel.

### PS 825 R OR L – Single Pipe Axle Support

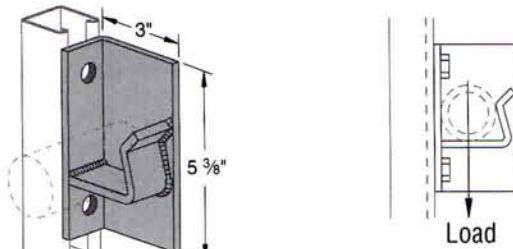

Right Hand Illustrated

Weight/100 pcs: 220 lbs.

Load Rating: 2000 lbs.

NOTE: Specify R (Right) or L (Left) when ordering.

### PS 826 – Double Pipe Axle Support

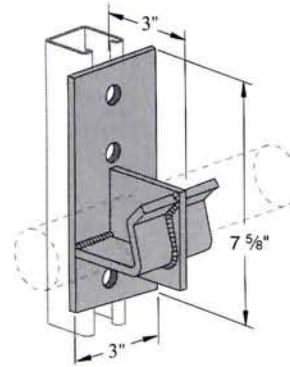

Weight/100 pcs.: 310 lbs.

Load Rating: 4000 lbs.



**General Information**

Finish: Painted green or Hot Dipped Galvanized  
Order By: No., Size & Finish

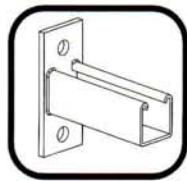

**PS 2401 thru PS 2403 – Ladder Run**

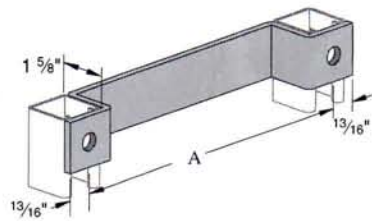

Part No.	"A" Hole to Hole	Wt./ 100 pcs
PS 2401	12"	186
PS 2402	15"	221
PS 2403	18"	254

**PS 2404 thru PS 2408 – Wall Ladder Bracket**

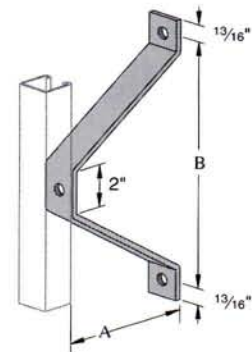

Part No.	A	B	Wt./ 100 pcs
PS 2404	2 3/8"	6"	113
PS 2405	4 3/8"	8"	164
PS 2406	6 3/8"	10"	216
PS 2407	8 3/8"	12"	267
PS 2408	10 3/8"	14"	318

**PS 2422 – 37 1/2° Degree Stair Tread Support**

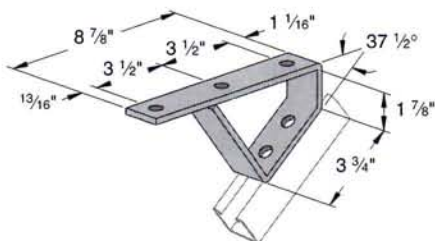

Weight/100 pcs: 213 lbs.

**PS 2421 – 45° Degree Stair Tread Support**

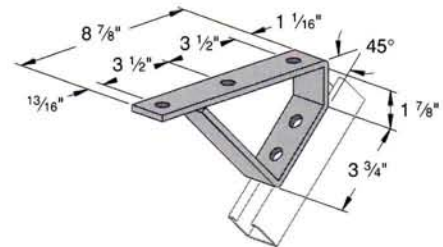

Weight/100 pcs: 220 lbs.



# ROLLERS



## Materials & Manufacturing Specifications

### **MATERIAL:**

Power-Strut pipe rollers consist of cast iron rollers and steel brackets. The steel brackets are punched from hot rolled, pickled and oiled mild steel.

### **STANDARD FINISH:**

Standard finish for the roller is plain white while brackets are painted green or electro-galvanized.

### **ORDERING INFORMATION:**

When ordering, add the length or size and finish to the part number. See page 5 for finish abbreviations and an example.

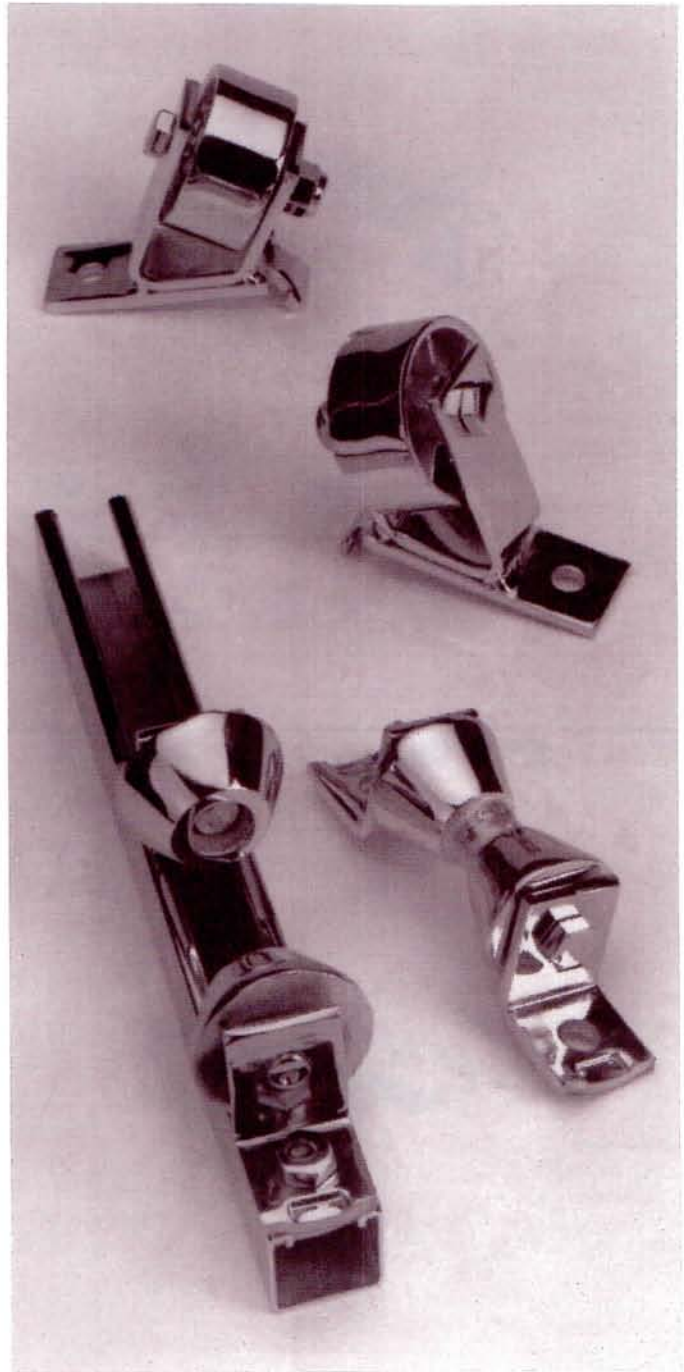





General Information

Order By: No. & Size



**PS 1901 – Two-Piece Pipe Roller**

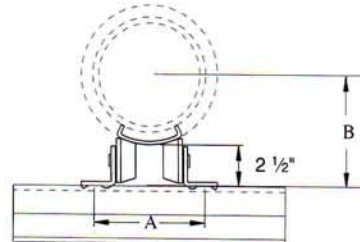
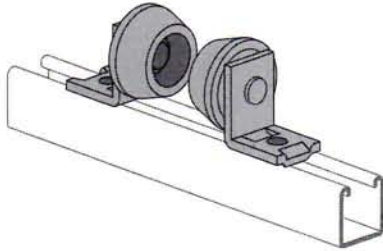

Use With: 1-8" pipe  
Load Rating: 500 lbs.

Pipe Size	A	B
1"	3 7/8"	3"
1 1/4"	4 1/16"	3 3/16"
1 1/2"	4 3/16"	3 5/16"
2"	4 3/8"	3 1/2"
2 1/2"	4 5/8"	3 11/16"
3"	4 15/16"	3 15/16"
3 1/2"	5 3/16"	4 3/16"
4"	5 7/16"	4 3/8"
5"	6"	4 7/8"
6"	6 1/2"	5 5/16"
8"	7 1/2"	6 3/16"

Material: Bracket - steel; Roller - cast iron (or aluminum)  
Finish: Green or galvanized; Roller - plain  
Weight/100 pair: 268 lbs.

**PS 815 – Two-Piece, Heavy Duty Pipe Roller**

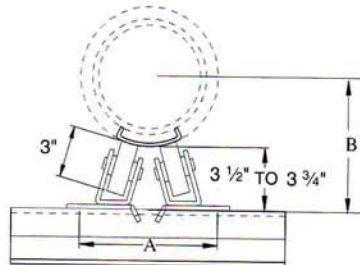
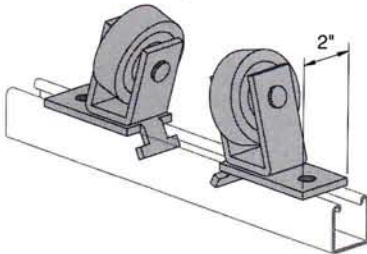

Use With: 6-18" pipe  
Load Rating: 1500 lbs.

Pipe Size	A	B
6"	10 13/16"	6 9/16"
8"	11 13/16"	7 3/8"
10"	12 7/8"	8 5/16"
12"	13 7/8"	9 3/16"
14"	14 1/2"	9 3/4"
16"	15 1/2"	10 5/8"
18"	16 1/2"	11 7/16"

Material: Bracket - steel; Roller - cast iron  
Finish: Green or galvanized; Roller - plain  
Weight/100 pair: 680 lbs.

**PS 1902 – Pipe-Roller Assembly**

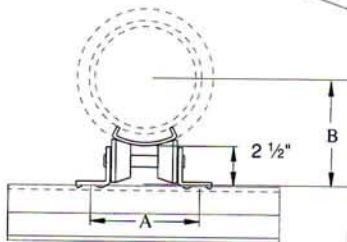
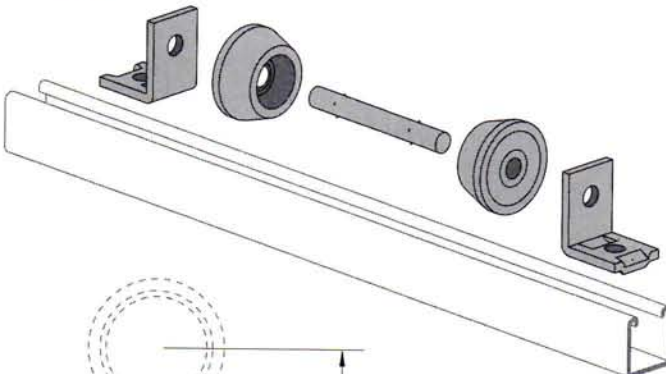

Size	Pipe Size	A	B	Wt./ 100 pcs
1-2"	1"	2 15/16"	4 7/16"	299
	1 1/4"	3 1/8"	4 7/16"	
	1 1/2"	3 1/4"	4 7/16"	
2 1/2 – 3 1/2"	2"	3 1/2"	4 7/16"	304
	2 1/2"	4 7/8"	3 11/16"	
	3"	4 7/8"	4 1/16"	
4 – 6"	3 1/2"	4 7/8"	4 5/16"	311
	4"	6"	4 5/16"	
	5"	6"	4 15/16"	
8"	6"	6"	5 1/2"	319
	8"	7 1/4"	6 5/16"	

Material: Brackets and shaft - steel; Rollers - cast iron  
Finish: Brackets - painted green or galvanized;  
Shaft - electro-galvanized; Rollers - plain

Load Rating: 750 lbs.

# ROLLERS



General Information

Order By: No. & Size



## PS 1911 – Pipe Roller

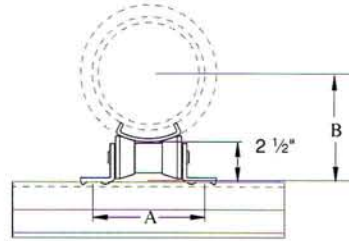
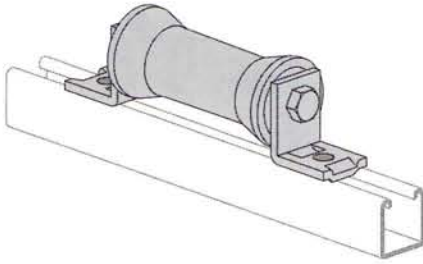

Size	Fits Pipe Size	A	B	Wt./ 100 pcs
2 – 3 1/2"	2"	5"	3"	160
	2 1/2"	5"	3 1/4"	
	3"	5"	3 5/8"	
4 – 6"	3 1/2"	5"	3 7/8"	215
	4"	5 7/8"	4 5/16"	
	5"	5 7/8"	4 7/8"	
8 – 10"	6"	5 7/8"	5 7/16"	525
	8"	8 5/16"	7 1/8"	
	10"	8 5/16"	8 1/4"	
12 – 14"	12"	10 7/8"	9 7/8"	1025
	14"	10 7/8"	10 1/2"	

Material: Brackets and shaft - steel; Rollers - cast iron

Finish: Brackets - painted green or galvanized; Shaft - electro-galvanized; Rollers - plain

Load Rating: 950 lbs.

## PS 816 – Three Piece, Heavy Duty Pipe Roller

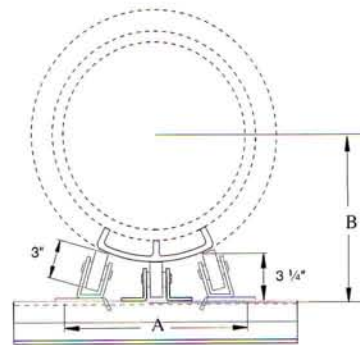
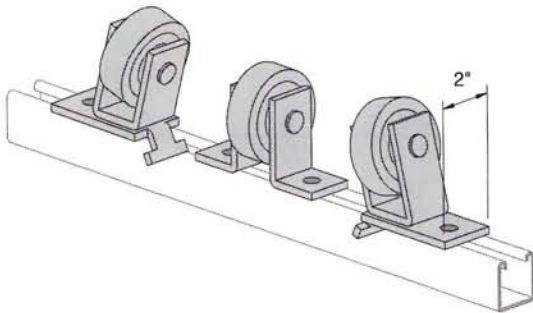

Material: Brackets - steel; Roller - cast iron

Finish: Brackets - painted green or galvanized; Roller - plain

Weight/100 units: 1046 lbs.

Use With: 20-30" pipe

Load Rating: 2000 lbs.

Fits Pipe Size	A	B
20"	18 1/2"	12 1/4"
24"	19 9/16"	14 1/4"
30"	21 1/16"	17 1/4"



## BEAM CLAMPS



### Materials & Manufacturing Specifications

**MATERIAL:**

Power-Strut beam clamps are cold formed from hot rolled, pickled and oiled steel. Square head, cup point set screws are furnished where noted. Cast beam clamps are made from high quality malleable iron.

**STANDARD FINISH:**

Standard finish is plain or electro-galvanized.

**ORDERING INFORMATION:**

When ordering, add the length or size and finish to the part number. See page 5 for finish abbreviations and an example.

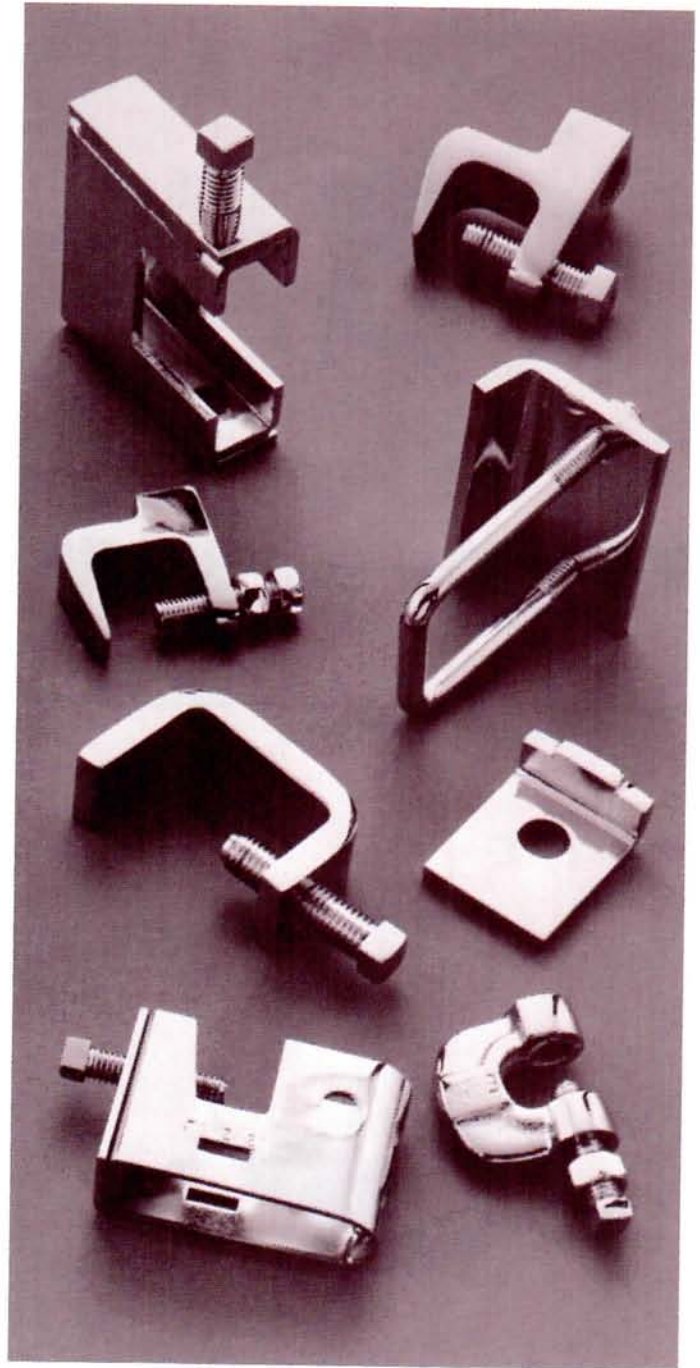

# BEAM CLAMPS

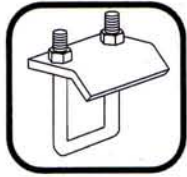

## General Information

Finish: Painted green or Electro-Galvanized  
 NOTE: Use in pairs or with other support.  
 Order By: No. & Finish



### PS 855 – Angular “I” Beam Clamp

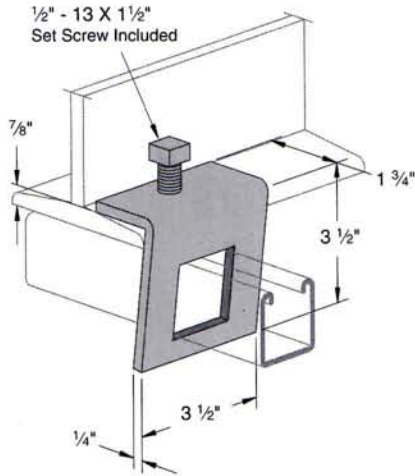

Part No.	Use With	A	Load Rating	Wt./ 100 pcs.
PS 855-1	PS 200, PS 210	3 3/4	500	107
PS 855-2	PS 500	2 7/8	500	98

### PS 2651 – Beam Clamp

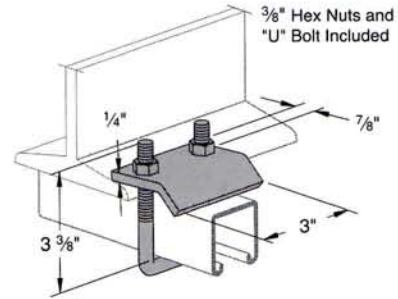

Part No.	Use With	A	Load Rating	Wt./ 100 pcs.
PS 2651 T1	PS 200, PS 210 PS 300, PS 400 PS 500, PS 520	3 3/4	1000	80
PS 2651 T2	PS 100, PS 150 PS 200 2T3	5 3/8	1000	80

Finish: Electro-galvanized

### PS 2657 – Double U Beam Clamp

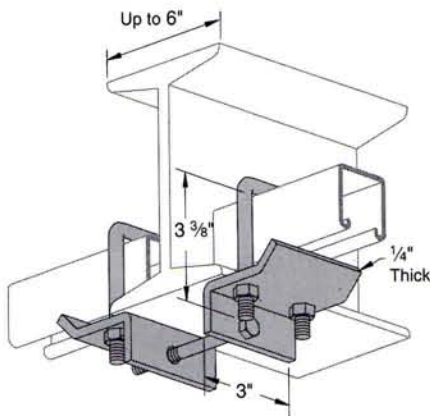

Specify 6" or 12" max. flange width (Example: PS 2657 T1-6")  
 T1 Use with PS 200, PS 210, PS 300, PS 400, PS 500, PS 520  
 T2 Use with PS 100, PS 150, PS 200 2T3

### PS 2656 – U Bolt Beam Clamp With Hook

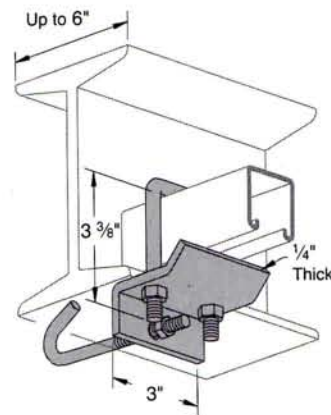

Specify 6" or 12" max. flange width (Example: PS 2656 T1-6")  
 T1 Use with PS 200, PS 210, PS 300, PS 400, PS 500, PS 520  
 T2 Use with PS 100, PS 150, PS 200 2T3



**General Information**

Finish: Painted green or Electro-Galvanized  
 NOTE: Use in pairs or with other support.  
 Order By: No. & Finish

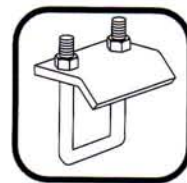

**PS 685 – Beam Clamp**

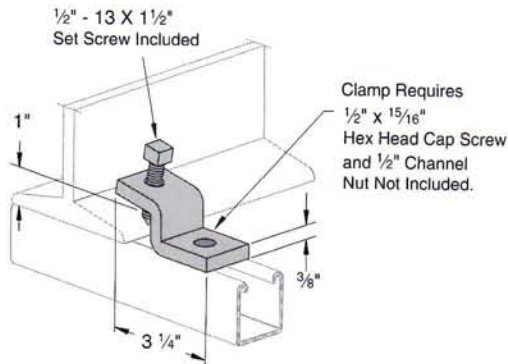

Stock Thickness: 3/8"  
 Weight/100 pcs: 63 lbs.  
 Load Rating: 450 lbs.

**PS 686 – Beam Clamp**

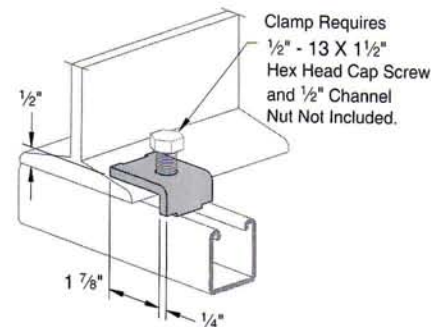

Weight/100 pcs: 26 lbs.  
 Load Rating: 600 lbs. with 12 ga. channel  
 500 lbs. with 14 ga. channel  
 NOTE: Order PS 6024 1/2" x 1 3/4" separately.

**PS 2653 – Purlin Clamp**

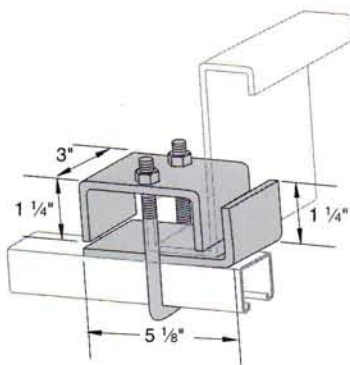

Part No.	Use With	Load Rating	Wt./ 100 pcs.
PS 2653 T1	PS 200, PS 210, PS 300	1200	179
PS 2653 T2	PS 100, PS 150, PS 200 2T3	1200	175

**PS 907, PS 998 – "I" Beam Clamp**

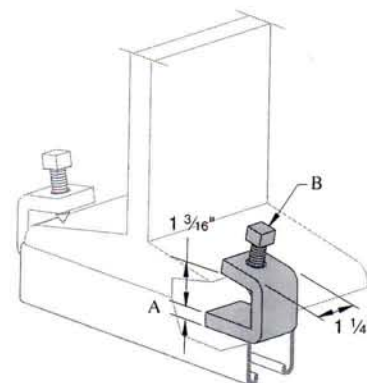

Stock Part #	Set Thickness	Load Rating Screw	Wt./ lbs.	100 pcs.
PS 907	1/4"	3/8"	450	26
PS 998	3/8"	1/2"	900	64

Finish: Electro-galvanized

# BEAM CLAMPS

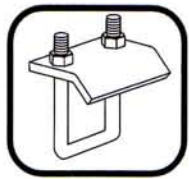

## General Information

Stock Thickness: 1/4"  
 Finish: Painted green or Electro-Galvanized  
 Hole Diameter: 9/16"  
 NOTE: Use in pairs or with other support  
 Order By: No. & Size



### PS 916 – “I” Beam Clamp

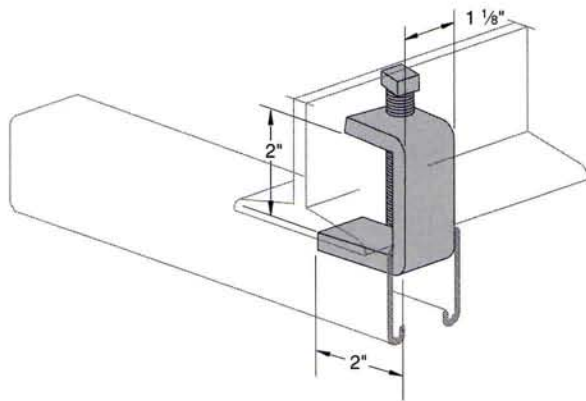

Stock Thickness: 3/8"  
 Weight/100 pcs: 72 lbs.  
 Load Rating: 900 lbs.

### PS 2622 – Beam Clamp

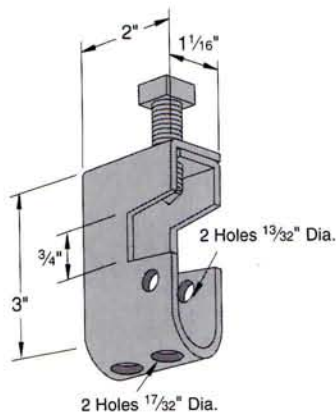

Weight/100 pcs: 41 lbs.  
 Load Rating: 300 lbs.  
 Assembly including PS 736 also available.  
 Order PS 2622/J6 or PS 2622/J10  
 NOTE: Adaptable for 1/4", 3/8" & 1/2" rod with PS 3201.

### PS 684 – “I” Beam Clamp

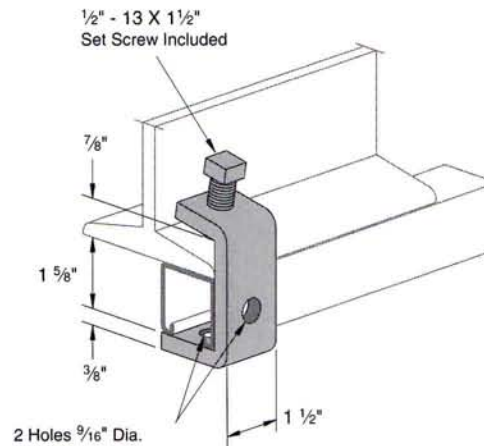

Stock Thickness: 3/8"  
 Weight/100 pcs: 94 lbs.  
 Load Rating: 500 lbs.

### PS 736 – Hook Rod Assembly

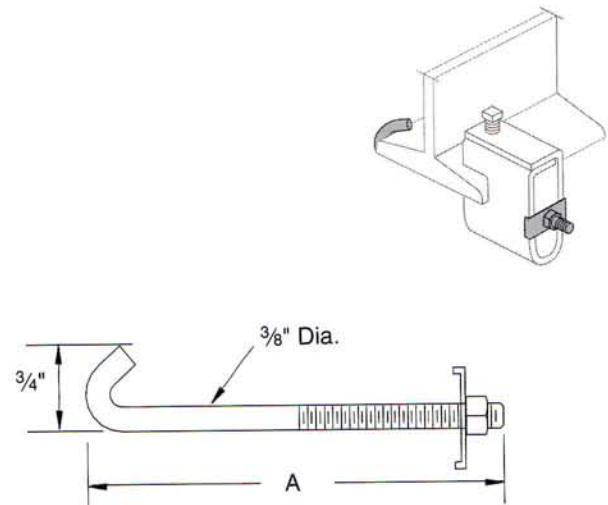

Part No.	Flange Max	Width Min	A Size	Wt./ 100 pcs
PS 736 J6	7"	3"	8 5/8"	24
PS 736 J10	11"	7"	12 5/8"	33

Use With: PS 2622 Beam Clamp



**General Information**

Finish: Electro-Galvanized  
Order By: No. & Size

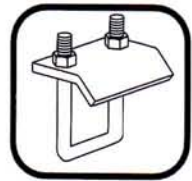

**PS 2623 – Swivel Adaptor**

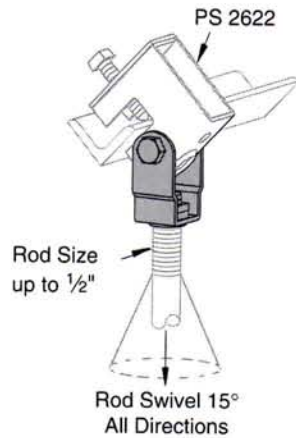
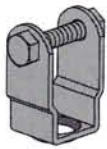

Weight/100 pcs: 31 lbs.

Use With: PS 2622 Beam Clamp or PS 2624 Wood Beam Hanger  
Load Rating: 300 lbs.

**PS 3201 – Swivel Nut**



Rod Size	Wt./ 100 pcs
1/4"	4
3/8"	4
1/2"	3

Use With: PS 2622 Beam Clamp

**PS 2624 – Wood Beam Hanger**

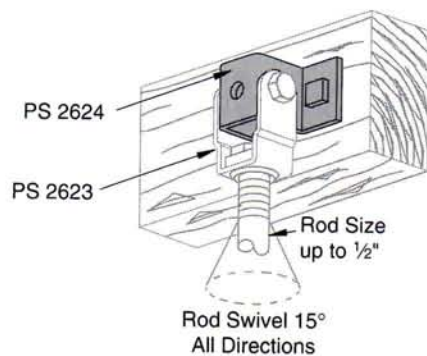
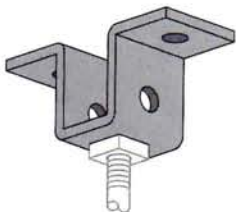

Weight/100 pcs: 22 lbs.

**PS 871 – Safety Anchor Strap**

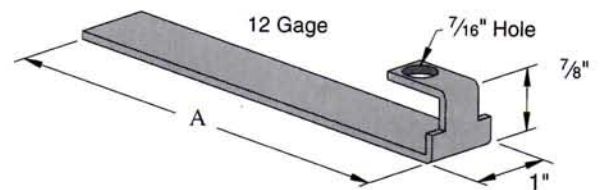
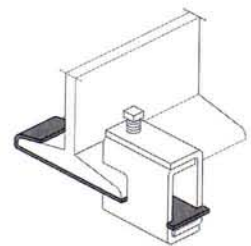

"A" Length	Wt./ 100 pcs
9"	33
12"	45
15"	57

Use with: PS 858 (except PS 858L 5/8), PS 865

# BEAM CLAMPS

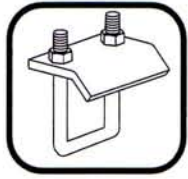

## General Information

**Material:** Steel  
**Finish:** Electro-Galvanized  
**Order By:** No. & Size



### PS 858, PS 858L – Heavy Duty Beam Clamp

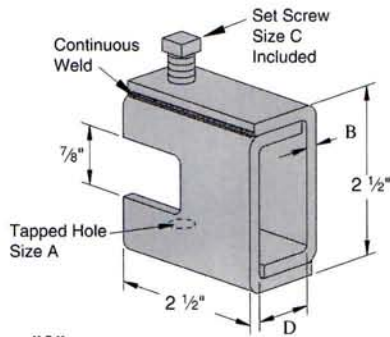

Part Number	"A" Rod Size	B	C	D	Load Ratings	Wt./ 100 pcs
PS 858 1/4	1/4" - 20	1/8"	3/8" x 1-1/2"	7/8"	650	67
PS 858 5/16	5/16" - 18	1/8"	3/8" x 1-1/2"	7/8"	650	67
PS 858L 3/8	3/8" - 16	1/8"	3/8" x 1-1/2"	7/8"	650	67
PS 858 3/8	3/8" - 16	3/16"	1/2" x 1-1/2"	15/16"	1100	100
PS 858L 1/2	1/2" - 13	3/16"	1/2" x 1-1/2"	15/16"	1100	100
PS 858 1/2	1/2" - 13	1/4"	1/2" x 1-1/2"	15/16"	1600	130
PS 858L 5/8	5/8" - 11	1/4"	1/2" x 1-1/2"	15/16"	1600	130
PS 858 5/8	5/8" - 11	5/16"	5/8" x 1-1/2"	1-5/16"	2400	160
PS 858 3/4	3/4" - 10	5/16"	5/8" x 1-1/2"	1-5/16"	2400	160

### PS 865 – Wide Throat Heavy Duty Beam Clamp

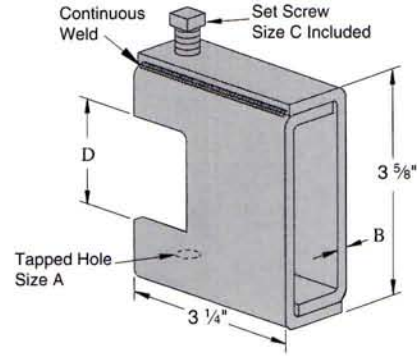

A Rod Size	B	C	D	Load Ratings	Wt./ 100 pcs
3/8"	1/2"	3/16"	1 3/16"	1100	151
1/2"	1/2"	1/4"	1 5/16"	1600	195
5/8"	5/8"	5/16"	1 7/16"	2400	225

### PS 2654 & PS 2654A – Column Attachment

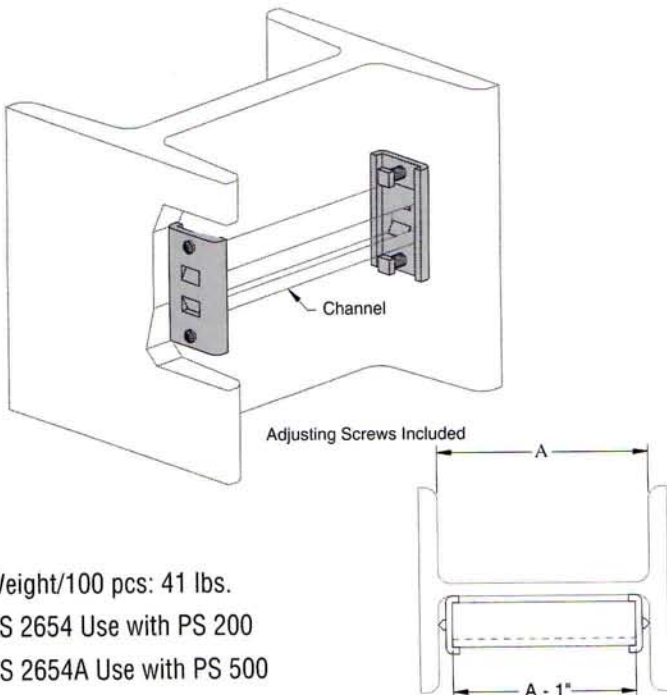

Weight/100 pcs: 41 lbs.  
 PS 2654 Use with PS 200  
 PS 2654A Use with PS 500  
 Slip Rating: 800 lbs.  
 NOTE: Column attachment can only be used in pairs.

### PS 2626 – Beam Clamp

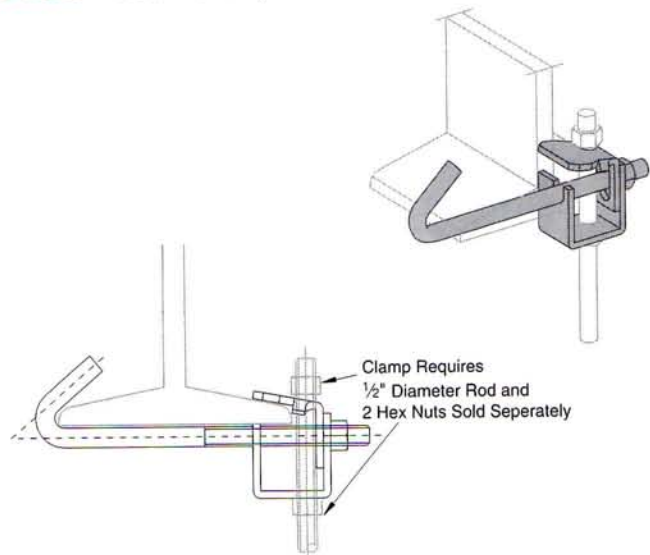

Part Number	"A" Range	Wt./100 pcs
PS 2626 6	2 1/2 - 6	125
PS 2626 9	5 1/2 - 9	140
PS 2626 12	8 1/2 - 12	171

Finish: Plain, painted green or electro-galvanized





**General Information**

Material: Steel  
 Finish: Electro-Galvanized  
 Order By: No. & Size



**PS 135X – Light Duty Beam Clamp**

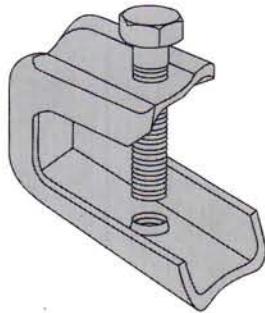

Material: Steel  
 Weight/100 pcs: 14 lbs.  
 Use With: 1/4" rod  
 Load Rating: 75 lbs.

**PS 95 – "C" Clamp**

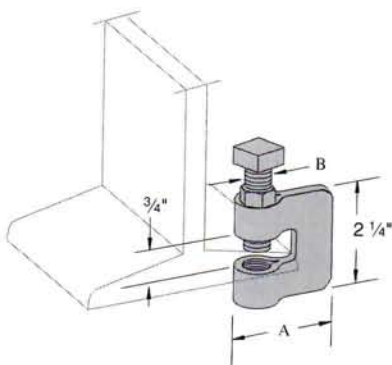

Rod Size	A	B	Load Rating	Wt./ 100 pcs
3/8"	2 5/16"	3/8"	330	35
1/2"	2 1/4"	1/2"	380	41
5/8"	2 3/8"	5/8"	450	67
3/4"	2 1/4"	1/2"	500	72

Material: Steel  
 NOTE: UL Listed for 3/8" rod.

**PS 85 – Rod or Insulator Support**

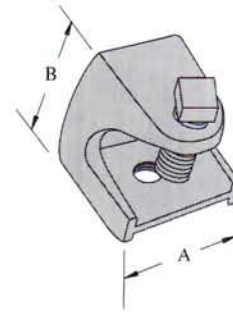

7/8" Maximum Flange Thickness

Rod Size	A	B	Load Ratings	Wt./ 100 pcs
1/4"	1 1/8"	1 1/4"	150	23
3/8"	2"	2"	350	95
1/2"	2 5/8"	2 1/2"	400	195

Material: Malleable Iron

**PS 86 – "C" Clamp**

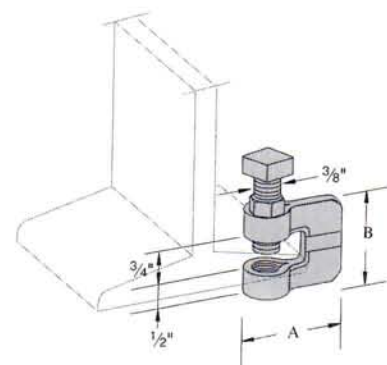

Rod Size	A	B	Load Rating	Wt./ 100 pcs
3/8"	1 11/16"	1 3/4"	400	38
1/2"	1 23/32"	1 3/4"	400	52
5/8"	1 15/16"	2"	450	68
3/4"	2 1/32"	2"	600	128

Material: Malleable Iron, Steel Set Screw  
 NOTE: UL Listed for 3/8" rod.

# BEAM CLAMPS

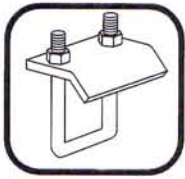

## General Information

Finish: Plain or Electro-Galvanized  
Order By: No., Size & Finish



## PS 93 – Universal “C” Clamp

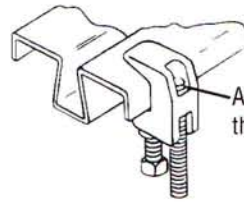
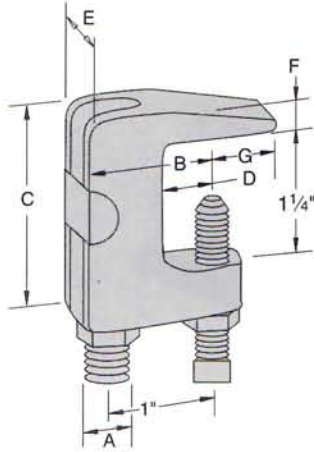

At least one full thread must be exposed

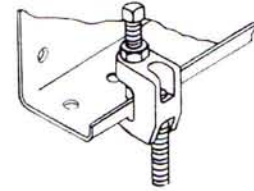

• Maximum temperature of 450° F

Rod Size	DIMENSIONS (Inches)							Max. Pipe Size	Max. Load (Lbs.)		Weight/ 100 pcs
	A	B	C	D	E	F	G		Top	Bottom	
3/8	1 5/16	2 5/32	2 5/32	9/16	3/8	5/8	4	500	250	41	
1/2	1 3/8	2 11/32	2 11/32	1/2	7/16	13/16	8	950	760	75	

Material: Malleable Iron, Steel Set Screw

## PS 94 – Wide Throat Top Beam “C” Clamp

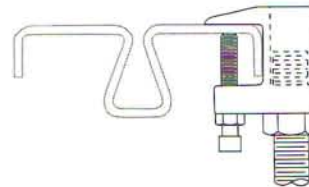
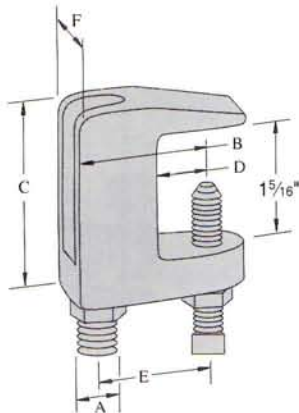

• Maximum temperature of 450° F

Rod Size	DIMENSIONS (Inches)						Max. Pipe Size	Max. Load (Lbs.)	Weight/ 100 pcs
	A	B	C	D	E	F			
5/8	1 3/4	2 1/4	3/4	1 1/4	1	10	1200	66	
3/4	1 7/8	2 3/8	3/4	1 3/8	1 3/16	12	1600	83	

Material: Malleable Iron, Steel Set Screw

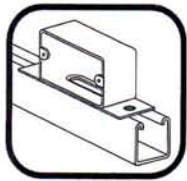

## Materials & Manufacturing Specifications

### **GENERAL:**

Power-Strut meets the specific needs of today's electrical projects by offering a versatile means of supporting lighting, conduits, cable and other portions of an electrical system. In addition, Power-Strut is listed as an electrical raceway by Underwriters laboratories as specified by the National Electric Code (Article 352), and CSA approved in accordance with the Canadian Electrical Code (Part 1). Refer to page 96 for raceway wire fill information.

### **MATERIAL:**

Power-Strut electrical raceways are cold formed from low carbon steel and meet the requirements of ASTM A-570 Grade 33 in painted green material or ASTM A-653 Grade 33 in pre-galvanized material. Plain or electro-galvanized fittings conform to the ASTM A-635 or ASTM A-36 standards while Pre-galvanized fittings meet the requirements of ASTM A-653 Grade 33.

### **STANDARD LENGTHS:**

Standard lengths of electrical raceway are 10 and 20 feet. The Power-Strut closure strips are available only in 10 feet lengths.

### **STANDARD FINISH:**

Electrical raceway channel is available in a painted green or pre-galvanized finish. All Power-Strut fittings are available in painted green or electro-galvanized finish. Many fittings are also available in pre-galvanized.

### **ORDERING INFORMATION:**

When ordering, add the length or size and finish to the part number. See page 5 for finish abbreviations and an example.



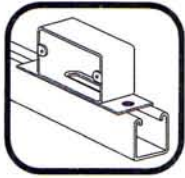

**General Information**

Finish: Painted green or Pre-Galvanized  
 Stock Length: 10 feet & 20 feet  
 Order By: No. & Size



**SOLID RACEWAY\***

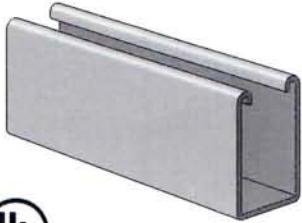

Part No.	Section Height
PS 100	3 1/4"
PS 150	2 7/16"
PS 200	1 5/8"
PS 210	1 5/8"
PS 300	1 3/8"
PS 400	1"
PS 500	13/16"



**KNOCK-OUT RACEWAY\***

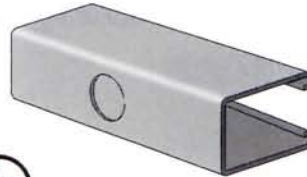

Part No.	Section Height
PS 100 K06	3 1/4"
PS 150 K06	2 7/16"
PS 200 K06	1 5/8"
PS 210 K06	1 5/8"
PS 300 K06	1 3/8"
PS 400 K06	1"



**Maximum Number of Wires Types**  
 AVB, FEP, FEBP, RH, RHH, RHW, RUH,  
 RUW, T, TW, THHN, THWN, THW, XHHW

	Raceway Part Numbers	Wt./ 100 Ft.	Height of Section Inches	Wire Size AWG*				
				14	12	10	8	6
<b>Table A</b> – Maximum number of conductors when raceway is installed to support and supply electric discharge type lighting fixtures when raceway wiring is suitable for at least 75 C. EXCEPTION: Wire suitable for 60 C may be used when clearance between raceway and fixtures is at least 1/2 inch.	PS 100, PS 100 K06	305	3 1/4"	10	10	8	6	4
	PS 150, PS 150 K06	247	2 7/16"	10	10	8	6	4
	PS 200, PS 200 K06	190	1 5/8"	6	6	5	4	2
	PS 210, PS 210 K06	141	1 5/8"	6	6	5	4	2
	PS 300, PS 300 K06	170	1 3/8"	5	4	4	3	2
	PS 400, PS 400 K06	146	1"	4	3	0	0	0
<b>Table B</b> – Maximum number of conductors when raceway is installed to support and supply electric discharge type lighting fixtures when raceway wiring is suitable for at least 75 C and clearance between raceway and fixtures is at least 1/8 inch.	PS 100, PS 100 K06	305	3 1/4"	10	10	10	9	6
	PS 150, PS 150 K06	247	2 7/16"	10	10	10	8	6
	PS 200, PS 200 K06	190	1 5/8"	10	10	8	6	3
	PS 210, PS 210 K06	141	1 5/8"	10	10	8	6	3
	PS 300, PS 300 K06	170	1 3/8"	10	10	6	4	2
	PS 400, PS 400 K06	146	1"	6	6	0	0	0
<b>Table C</b> – Maximum number of conductors when raceway is not employed with fixtures OR where the clearance between the raceway and fixtures is greater than 1/2 inch.	PS 100, PS 100 K06	305	3 1/4"	50	42	35	20	13
	PS 150, PS 150 K06	247	2 7/16"	36	29	25	14	9
	PS 200, PS 200 K06	190	1 5/8"	22	18	15	9	5
	PS 210, PS 210 K06	141	1 5/8"	24	20	17	10	6
	PS 300, PS 300 K06	170	1 3/8"	18	15	13	7	5
	PS 400, PS 400 K06	146	1"	11	9	7	4	3
<b>Table C</b> – CSA Certified Maximum number of wires Types R, RW, RWU, T, TW	PS 100, PS 100 K06	305	3 1/4"	10	10	8	6	4
	PS 150, PS 150 K06	247	2 7/16"	10	10	8	6	4
	PS 200, PS 200 K06	190	1 5/8"	8	8	5	4	3
	PS 210, PS 210 K06	141	1 5/8"	8	8	5	4	3
	PS 300, PS 300 K06	170	1 3/8"	8	6	5	3	2
	PS 400, PS 400 K06	146	1"	4	3	0	0	0
PS 500	97	13/16"	4	3	0	0	0	

\*In all cases, the snap-in-cover, PS 707, is required to complete raceway enclosures.

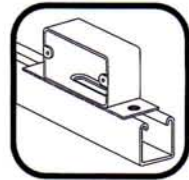

### TO INSTALL CHANNEL

1. Suspend and align PS-2632 Channel hanger from threaded rod at pre-determined level.
2. At floor working level install wiring in channel raceway and add a channel closure strip.
3. Lay raceway into pre-hung channel hanger. Close snap fastening door which securely locks raceway into position.

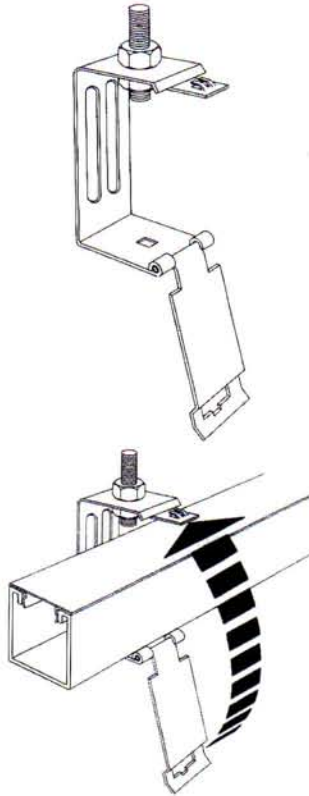
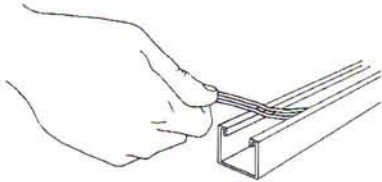

### TO INSTALL FLUORESCENT FIXTURE

1. Attach PS2631 Fixture Hanger to fixture with quick assembly wing-nut leaving door open.
2. Hook fixture over raceway. Close snap fastening door which securely locks fixture into position. Plug in fixture.

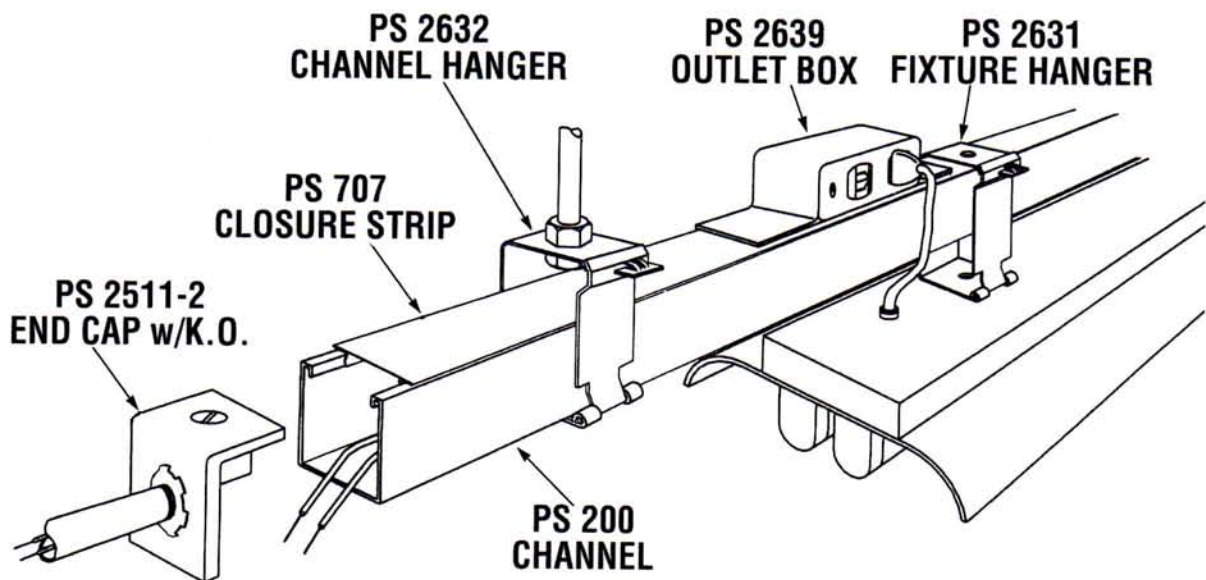
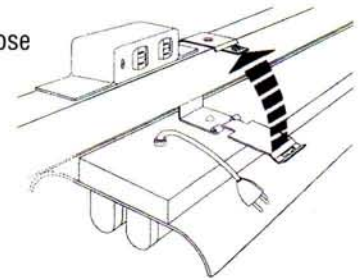
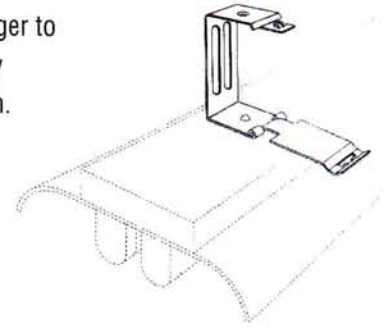

Complete installation in minutes. No screw, bolts or cotter pins to lose.

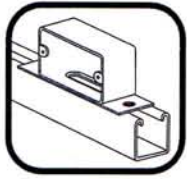

**KNOCK-OUT FLUORESCENT RACEWAY SYSTEM**

Listed by Underwriter's Laboratories, Inc. Fixture is attached to slot-up channel with Chase nipple, locknut and bushing through knock-outs in bottom of channel. Conduit connector fitting PS-2560 holds channel and fixture to pipe or rod.

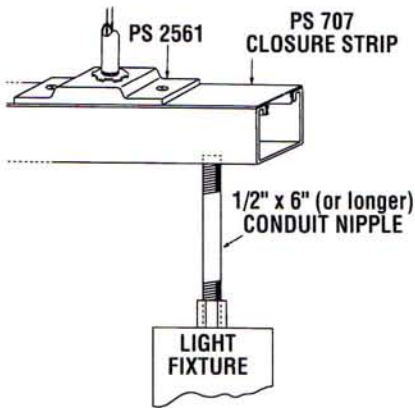
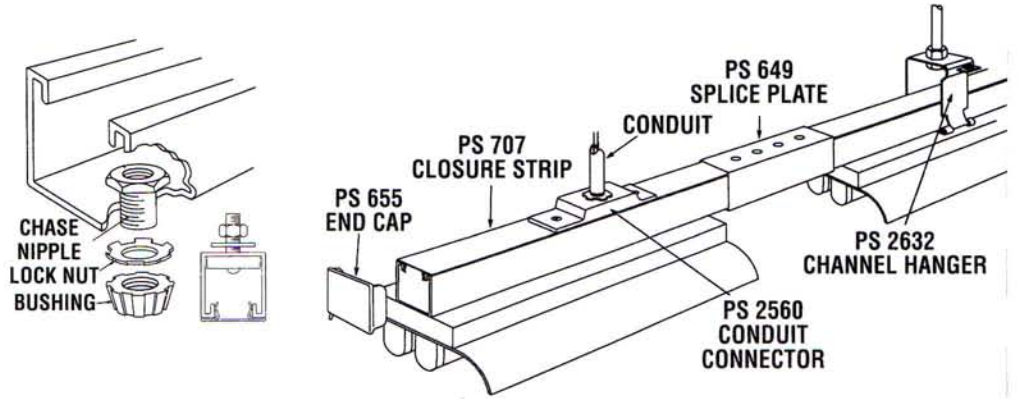

**KNOCK-OUT MERCURY VAPOR RACEWAY SYSTEM**

Listed by Underwriter's Laboratories, Inc. Fixture is attached to slot-up channel with Chase nipple, locknut and bushing through knock-outs in bottom of channel. Conduit connector fitting PS-2561 holds channel and fixture to pipe or rod.

**ECONOMY RACEWAY SYSTEM FLUORESCENT**

In this slot-down system the circuits run through the fixtures and only enter the channel where there is a break in the fixture run. At that point the fiber wire retainer holds wires in place and snap-in closure strip covers the area.

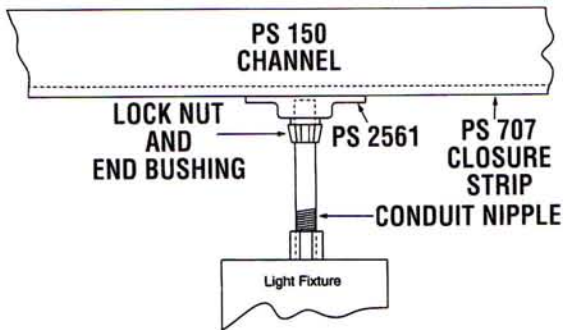
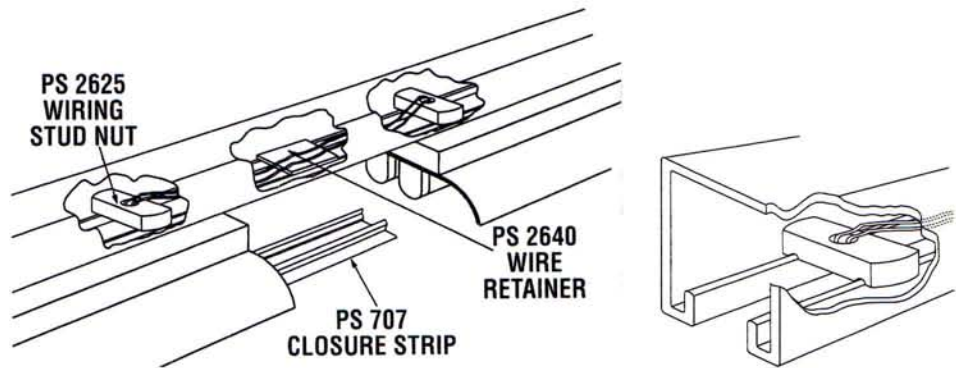

**SLOT DOWN MERCURY VAPOR SYSTEM**

In this slot down system the mercury vapor ballast is wired directly to the system.

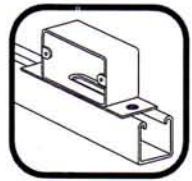

**BASIC FLUORESCENT SUPPORT SYSTEM**

Slot-down channel holds fixture firmly in place with spring nut and bolt. Fixtures may be added or relocated without changing the basic assembly.

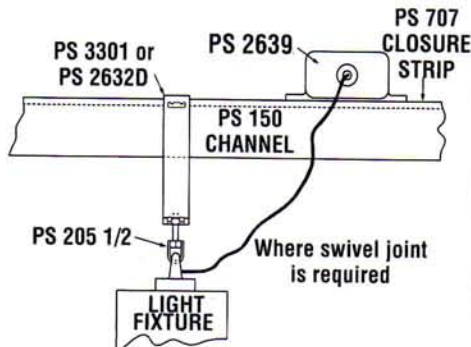
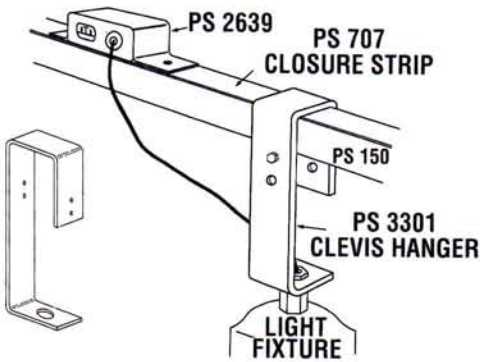
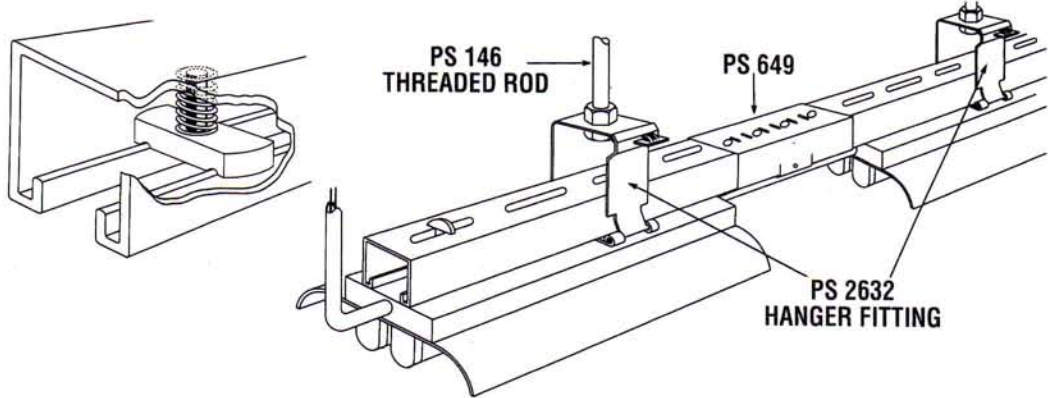

**BASIC MERCURY VAPOR SUPPORT SYSTEM – PS-3301 CLEVIS HANGER FOR USE WITH PS-150, PS-200**

In this slot up or down system, the fixture is supported by PS-3301 clevis hanger which is designed for use with both 1 5/8" and 2 7/16" deep channels.

**SLOTTED SUPPORT SYSTEM**

This system is designed for maximum ease of attaching fixture through slotted channel with shoulder bolt and provides positive alignment.

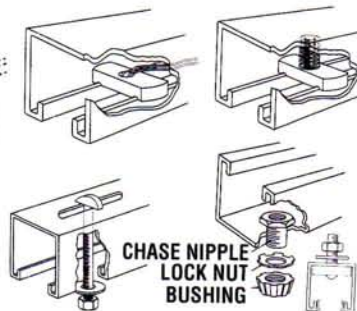
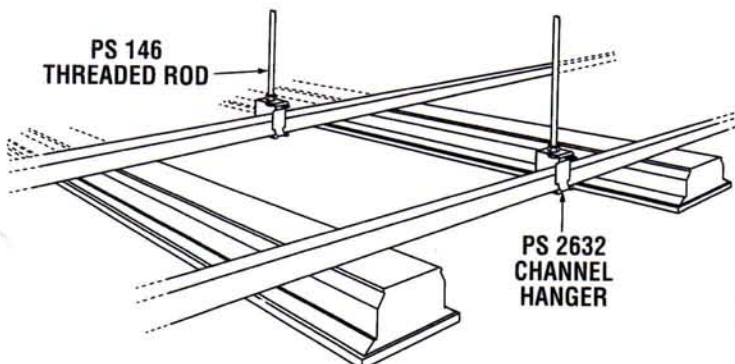
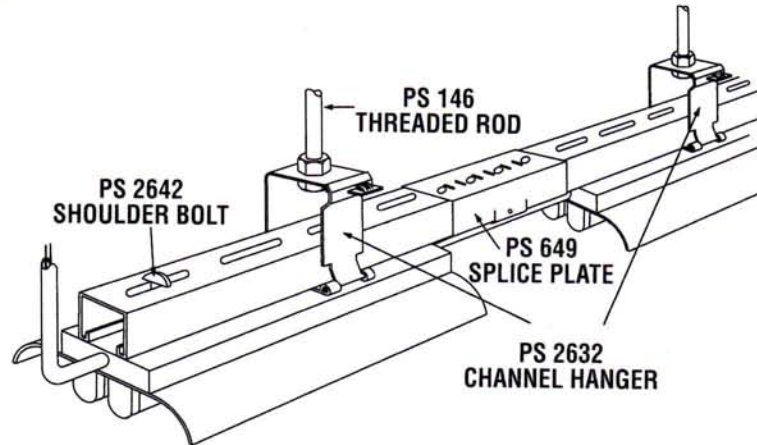
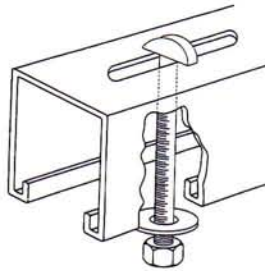

**GRID SYSTEM**

This system is used where fixtures are hung at right angles to Power-Strut raceways and support channels. Any of the features of the above systems can be adapted to this system. Ideal for egg-crate type drop ceiling installations.

# ELECTRICAL

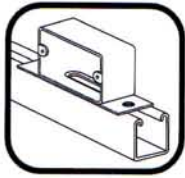

## General Information

Finish: Electro-galvanized  
 Stock Size (.105) PGAL  
 Order By: Part No., Size & Finish



## PS 655, PS 656, PS 901, PS 902, PS 930, PS 2580, PS 2585 – Raceway End Caps

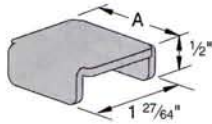

Part No.	Use With	Finish	Wt./ A	100 pcs
PS 902	PS 100	EG	3 1/4"	22
PS 2580	PS 150	EG	2 7/16"	18
PS 655	PS 200	EG	1 5/8"	11
PS 2585	PS 210	EG	1 5/8"	12
PS 656	PS 300	EG	1 3/8"	15
PS 901	PS 400	EG	1"	11
PS 930	PS 500	EG	13/16"	5

## PS 2511, PS 2581 – End Cap With Knock-Out

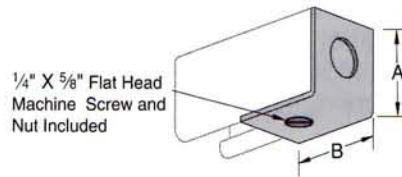

Part No.	Use With	Finish	A	B	Wt./ 100 pcs
PS 2511-1	PS 100	EG	3 1/4"	1 3/4"	3.1
PS 2511-2	PS 200, PS 210	EG	1 5/8"	1 3/4"	2.7
PS 2511-3	PS 300	EG	1 3/8"	1 3/4"	2.6
PS 2581	PS 150	EG	2 7/16"	2"	3.0

ASSEMBLY: End Cap Part, 1 Machine Screw, 1 Nut  
 Specify 1/2" or 3/4" knock-out

## PS 2560, PS 2561 – Conduit Connector Fitting

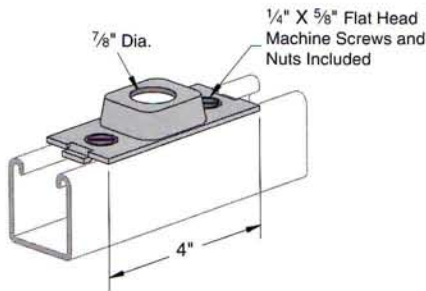

Part No.	Use With	Hole	Wt./ 100 pcs
PS 2560	1/2 Conduit"	7/8"	36
PS 2561	3/4 Conduit"	1 3/32"	36

Stock Size: (.060)

Assembly: Connector Fitting, 2 Nuts, 2 Bolts

## PS 2621 – Conduit Swivel Hanger

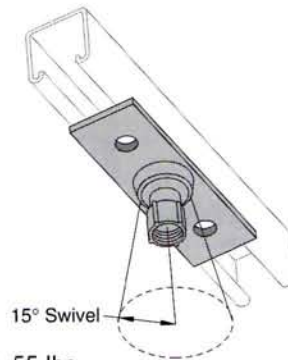

Weight/100 pcs: 55 lbs.

Use With: 1/2" and 3/4" conduit

Design Load: 200 lbs.

ASSEMBLY: 1 Swivel Hanger, 3/4X1/2" Bushing Adaptor

## PS 2640 – Wire Retainer



Material: Polypropylene  
 Weight/100 pcs: .30 lbs.

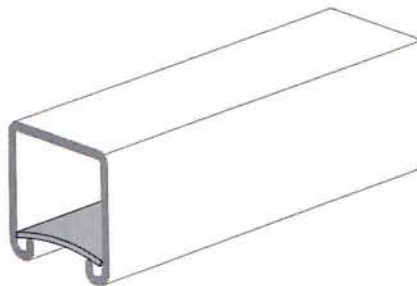





General Information

Finish: Electro-galvanized  
 Stock Size (.060)  
 Order By: No. and Size

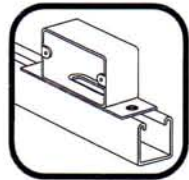

**PS 2632** – Swing Gate Channel Hanger

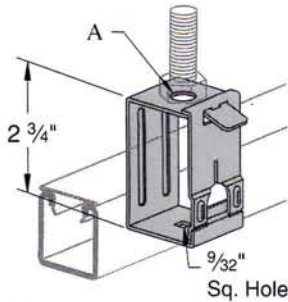

A Dia.	Use With
9/16"	1/2" Rod
7/8"	1/2" Conduit

Finish: Electro-galvanized  
 Weight/100 pcs: 25 lbs.  
 Use With: PS 200, PS 210, PS 300, PS 400 and PS 500  
 Load Rating: 90 lbs.

**PS 2632D** – Swing Gate Channel Hanger

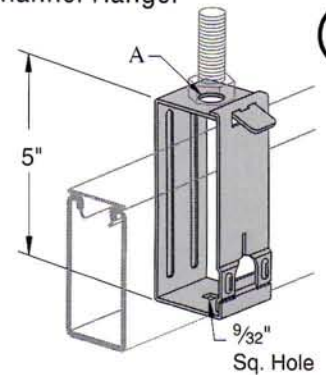

A Dia.	Use With
9/16"	1/2" Rod
7/8"	1/2" Conduit

Finish: Electro-galvanized  
 Weight/100 pcs: 34 lbs.  
 Use With: PS 100, PS 150, PS 200 2T3, and PS 210 2T3  
 Load Rating: 90 lbs.

**PS 659** – Channel Hanger

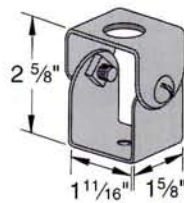

Weight/100 pcs: 28 lbs.  
 Use With: PS 400, PS 500  
 Load Rating: 150 lbs.  
 NOTE: Washers supplied to adapt to 3/8" or 1/2" rod

**PS 658** – Channel Hanger

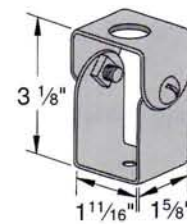

Weight/100 pcs: 30 lbs.  
 Use With: PS 200, PS 210, PS 300  
 Load Rating: 150 lbs.  
 NOTE: Washers supplied to adapt to 3/8" or 1/2" rod

**PS 803** – Fixture Wiring Nipple

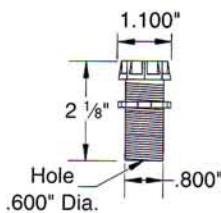

Assembly: 1/2" x 2" rigid conduit nipple  
 Bushing  
 Locknut  
 Weight/100 pcs: 14 lbs.

**PS 2625** – Wiring Stud Nut

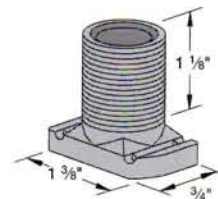

Material: Aluminum casting  
 Size: 1/2" - 14 Amer. Std, conduit thread  
 Weight/100 pcs: 10 lbs.

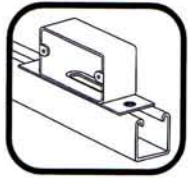

**General Information**

Finish: Electro-galvanized  
Order By: No. and Finish



**PS 2631 – Swing Gate Fixture Hanger**

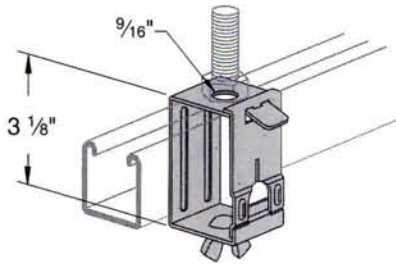

Weight/100 pcs: 27 lbs.

Use With: PS 200, PS 210, PS 300, PS 400 and PS 500

Load Rating: 90 lbs.

NOTE: Includes Bolt and Wing Nut for connection to fluorescent fixtures.

**PS 2631D – Swing Gate Fixture Hanger**

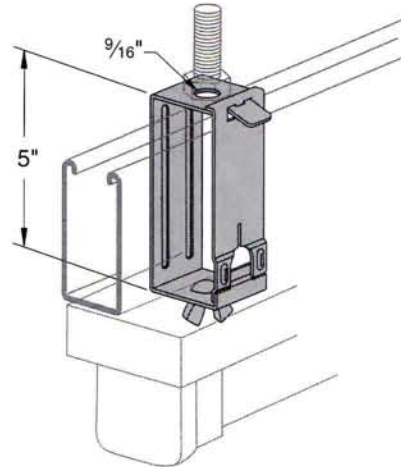

Weight/100 pcs: 36 lbs.

Use With: PS 100, PS 150, PS 200 2T3, PS 210 2T3

Load Rating: 90 lbs.

NOTE: Includes Bolt and Wing Nut for connection to fluorescent fixtures.

**PS 3301 – Mercury Vapor Fixture Hanger**

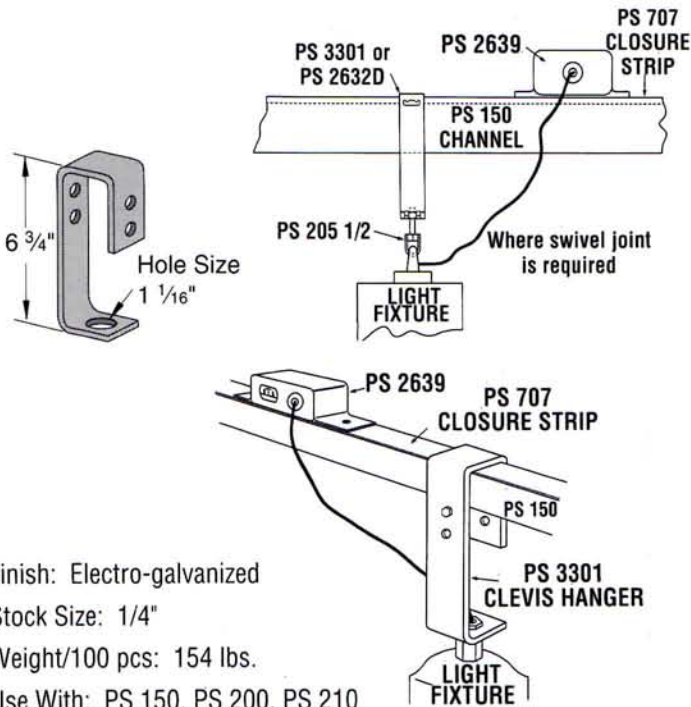

Finish: Electro-galvanized

Stock Size: 1/4"

Weight/100 pcs: 154 lbs.

Use With: PS 150, PS 200, PS 210

NOTE: Supports fixture in slot up or down system.

**PS 807 – Channel Hanger**

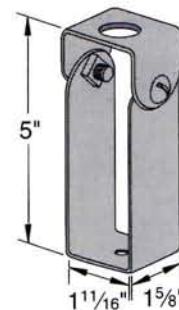

Weight/100 pcs: 35 lbs.

Use With: PS 100, PS 150

Load Rating: 150 lbs.

NOTE: Washers supplied to adapt to 3/8" or 1/2" rod



General Information

Finish: Electro-galvanized  
Order By: No. and Size

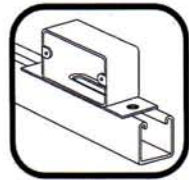

**PS 2636** – Fixture Stud Nut

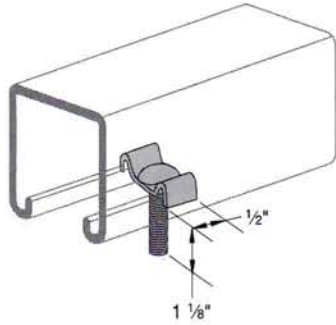

Size: 1/4" x 20 thread, 1 1/4" long  
Weight/100 pcs: 5 lbs.

**PS 2637** – Fixture Nut

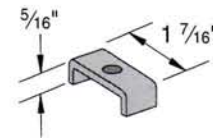

Size: Tapped for 1/4" - 20 thread  
Weight/100 pcs: 2 lbs.

**PS 702** – Fluorescent Fixture Hanger

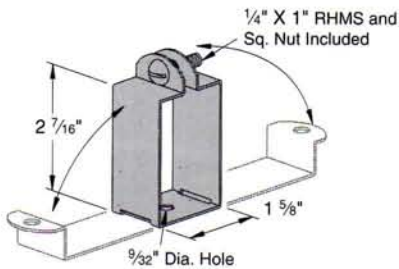

Hanger provides more than 1/2" space between channel and fixtures.  
Use hanger for PS 200, PS 210 & PS 300.  
Load Rating: 120 lbs.  
Weight/100 pcs: 19 lbs.

**PS 703** – Fluorescent Fixture Hanger

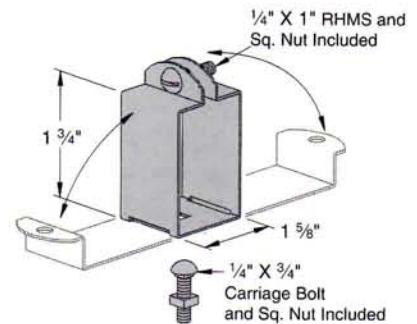

Hanger provides more than 1/8" space between channel and fixtures.  
Use hanger for PS 200 & PS 210.  
Load Rating: 120 lbs.  
Weight/100 pcs: 17 lbs.

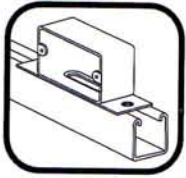

**General Information**

Finish: Electro-galvanized  
Order By: No. and Size



**PS 702 D – Fluorescent Fixture Hanger**

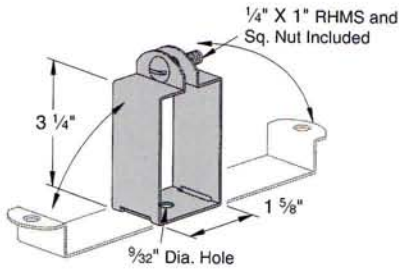

Hanger provides more than 1/2" space between channel and fixtures.

Use hanger for PS 150.

Load Rating: 120 lbs.

Weight/100 pcs: 20 lbs.

**PS 703 D – Fluorescent Fixture Hanger**

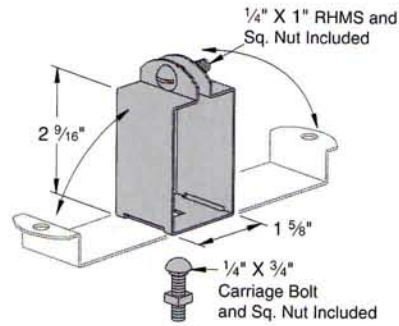

Hanger provides more than 1/8" space between channel and fixtures.

Use hanger for PS 150.

Load Rating: 120 lbs.

Weight/100 pcs: 18 lbs.

**PS 707 – Raceway Closure Strip**

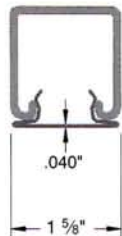

Finish: Painted green and pre-galvanized

Stock Size: (.042) GRN, (.046) PGAL

Stock Length: 10 ft.

Wt. 47 Lbs./C ft.

Use With: All 1 5/8" wide channel.

**PS 707 – Aluminum Raceway Closure Strip**

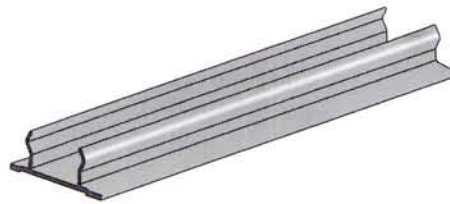

Material 6063-T6 Aluminum, Copper Free, Extruded

Stock Size: (.051)

Stock Length: 10 ft.

Wt. 21 Lbs./ ft.

Use With: All 1 5/8" wide channel



General Information

Finish: Electro-galvanized  
Order By: No. and Size

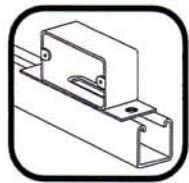

**PS 649, PS 693, PS 694, PS 805, PS 942, PS 2582 – Electrical Joiner**

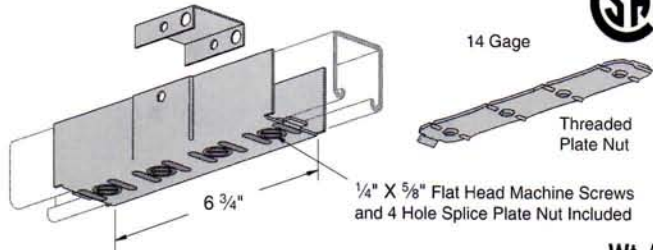

Part No.	A	Use With	Finish	Wt./100 pcs
PS 805	3 1/4"	PS 100	EG, GRN	106
PS 2582	2 7/16"	PS 150	EG	103
PS 649	1 5/8"	PS 200, PS 210	EG, GRN	100
PS 694	1 3/8"	PS 300	EG, GRN	97
PS 693	1"	PS 400	EG, GRN	97
PS 942	13/16"	PS 500, PS 520	EG, GRN	80

Stock Size: (.060)

Assembly: 1 Splice Plate Clevis (GRN), 1 Tapped Plate (EG), 1 Backplate (GRN), 4 Flat Head Machine Screws (EG).

**PS 2662 - A – Hub Assembly**

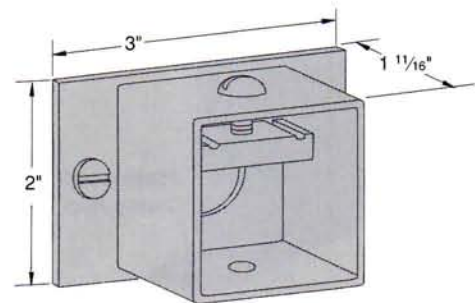

Use With: PS 200, PS 210

Assembly: 1 Hub, 2 Screws, 1 Bolt, 1 Nut

NOTE: Add hub assemblies to the basic PS 2660 unit assembly to make 1, 2, 3 or 4-way junction box.

Weight/100 pcs: 27 lbs.

**PS 2660 – Junction Box**

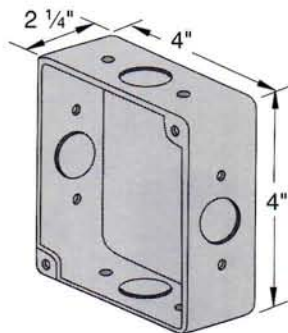

Weight/100 pcs: PS 2660 113 lbs.

NOTE: Add hub assemblies PS 2662-A to make 1, 2, 3 or 4-way junction box.

**PS 2661 – Junction Box Cover**

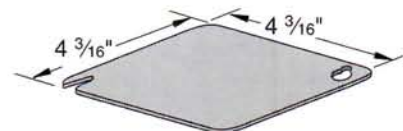

Weight/100 pcs: 30 lbs.

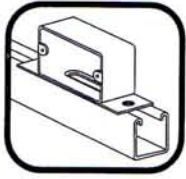

**General Information**

Finish: Electro-galvanized  
Order By: No. and Finish



**PS 2094 – 4" Receptacle Box With Knock-outs**

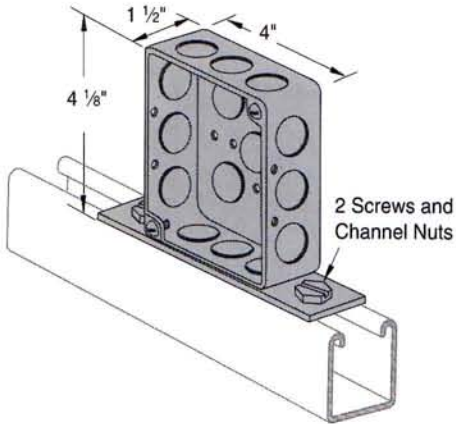

Stock Size: (.075)  
Weight/100 pcs: 93 lbs.  
Assembly: 1 Box, 2 Screws, 2 Channel Nuts

**PS 2639 – Outlet Box**

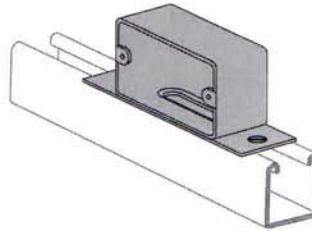

Stock Size: (.075)  
Weight/100 pcs: 88 lbs.  
Assembly: 1 Box, 2 Screws, 2 Channel Nuts

**PS 760 – Bus Duct Connection Clevis**

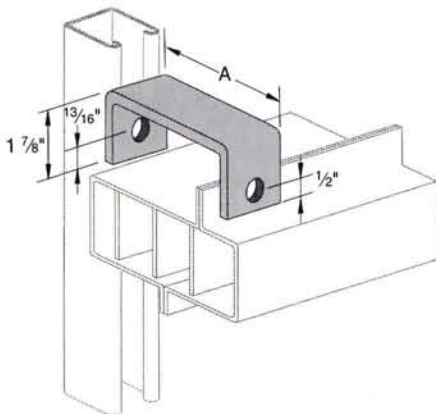

Part No.	Outside Width	Inside Width	Wt./ 100 pcs
PS 760-1	2 13/32"	1 29/32"	57
PS 760-2	3 25/32"	3 9/32"	73
PS 760-3	4 3/4"	4 1/4"	84

**PS 671 – Strut Suspension Member**

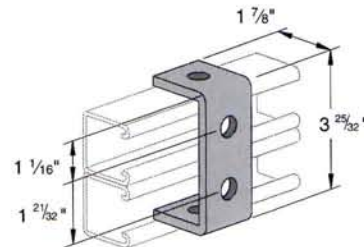

Weight/100 pcs: 70 lbs.



**General Information**

Finish: Electro-galvanized  
Order By: No. & Cable Size

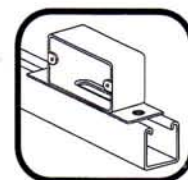

**PS 791 – Electrical Box Adapter Plate**

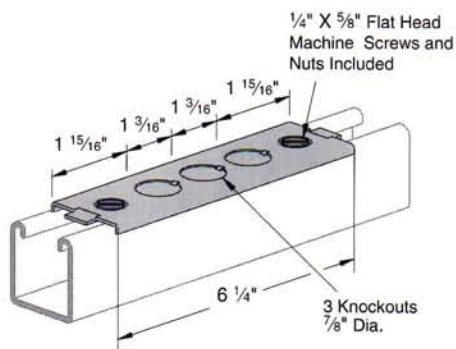

Stock Size: (.060)  
Weight/100 pcs: 35 lbs.  
Assembly: 1 Plate, 2 Screws, 2 Channel Nuts

**PS 2627 – Spacer Clevis**

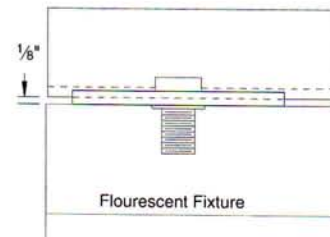
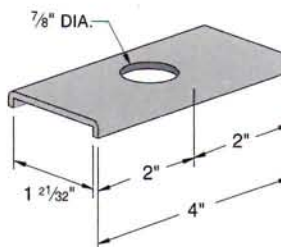

Weight/100 pcs: 24 lbs.  
Material: 12 gage

**PS 2800 – Inside Strut Joiner**

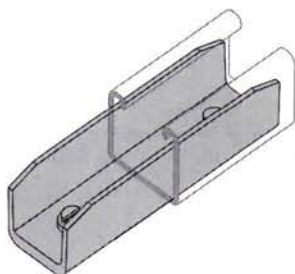

Material: Cast aluminum  
Weight/100 pcs: 20 lbs.  
Jam screws included

**PS 2802 – "Elbow" Inside Strut Joiner**

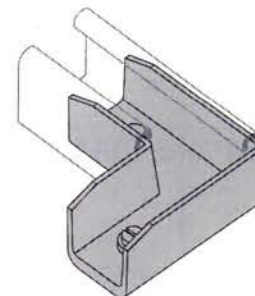

Material: Cast aluminum  
Weight/100 pcs: 27 lbs.  
Jam screws included

**PS 2801 – "T" Inside Strut Joiner**

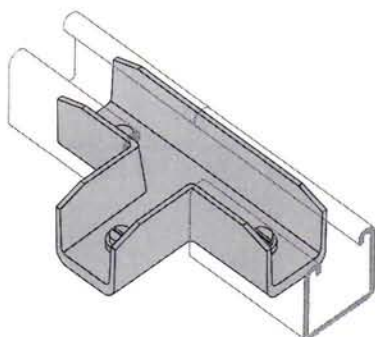

Material: Cast aluminum  
Weight/100 pcs: 35 lbs.  
Jam screws included

**PS 2803 – "Cross" Inside Strut Joiner**

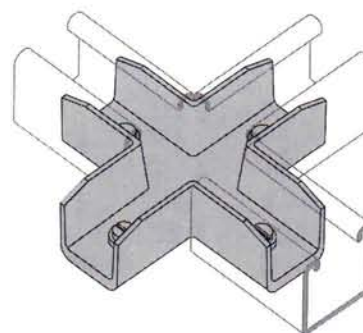

Material: Cast aluminum  
Weight/100 pcs: 45 lbs.  
Jam screws included

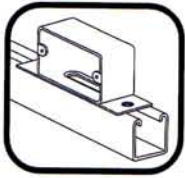

**General Information**

Material: White glaze, dry process porcelain, or Kiln-Dried Maple  
 Finish: Maple, Boiled in Parafin Until Penetration Averages 1/16"  
 Hardware, Electro-Galvanized  
 Order By: No. and Finish



**PS 1500 – Porcelain Cable Rack Insulators**

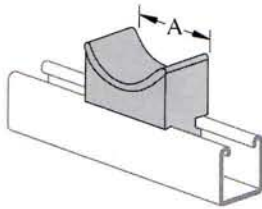

Cable Dia.	A	Wt./ 100 pcs
3"	3"	75
4 1/2"	4"	95

Use With: All 1 5/8" channel

**PS 1510 – Maple Cable Saddle**

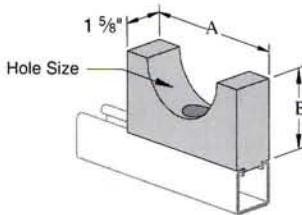

Cable Size	A	B	Wt./ 100 pcs
0" – 1"	3"	1 3/4"	31
1" – 1 1/2"	3 1/2"	2"	38
1 1/2" – 2"	4"	2 1/4"	47
2" – 2 1/2"	4 1/2"	2 1/2"	57
2 1/2" – 3"	5"	2 3/4"	68
3" – 3 1/2"	5 1/2"	3"	80
3 1/2" – 4"	6"	3 1/4"	94

Use With: All 1 5/8" Channel

Assembly: Maple Part, 1 Spring Nut, 1 Flat Head Screw

NOTE: Specify Cable Diameter

**PS 723 – Porcelain Cable Clamp**

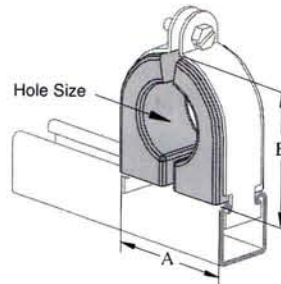

PS 1100 Size	Inside Diameter	A	B	Wt./ 100 pcs
1	3/8	1 7/8	1 15/32	51
	1/2			47
	5/8			46
1 1/2	3/4	2 3/8	2 1/32	85
	7/8			84
	1			83
	1 1/8			76
2	1 1/4	2 7/8	2 17/32	116
	1 3/8			115
	1 1/2			108
	1 5/8			100
	2			116
3	1 3/4	4	3 5/8	228
	1 7/8			224
	2			204
	2 1/8			184
3 1/2	2 1/4	4 1/2	4 1/8	255
	2 3/8			255
	2 1/2			250
	2 5/8			245
4	2 3/4	5 1/8	4 5/8	322
	2 7/8			301
	3			301
	3 1/8			296
5	3 1/4	6 1/8	5 11/32	460
	3 3/8			440
	3 1/2			433
	3 5/8			423
6	3 3/4	7 1/4	6 3/4	698
	3 7/8			678
	4			648
	4 1/8			638
6	4 1/4	7 1/4	6 3/4	648
	4 3/8			598
	4 1/2			588

Strap Material: Electro-galvanized steel

Use With: All 1 5/8" channel





**General Information**

**Material:** Kiln-Dried Maple  
**Finish:** Maple, Boiled in Parafin Until Penetration Averages 1/16"  
**Hardware,** Electro-Galvanized  
**Order By:** No., Type & Size

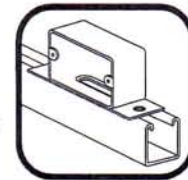

**PS 1610 – Maple Cable Clamp**

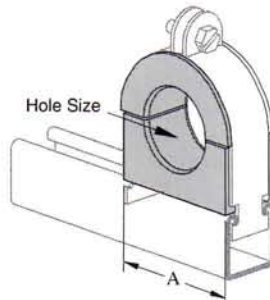

A Inside Diameter	B	PS 1100 Size	Wt./ 100 pcs
1/8 to 5/8	1 5/16	1	24
3/4 to 1 1/8	1 15/16	1 1/2	42
1 1/4 to 1 5/8	2 3/8	2	54
1 3/4 to 2 1/8	3 1/2	3	65
2 1/4 to 2 5/8	4	3 1/2	84
2 3/4 to 3 1/8	4 1/2	4	107
3 1/4 to 3 5/8	5 9/16	5	123
3 3/4 to 4 1/2	6 5/8	6	163

Use With: All 1 5/8" Wide Channel  
 Assembly: Maple Part, Pipe Clamp Assembly  
 NOTE: Specify Cable Diameter

**PS 1801 – Square Maple Cable Clamps**

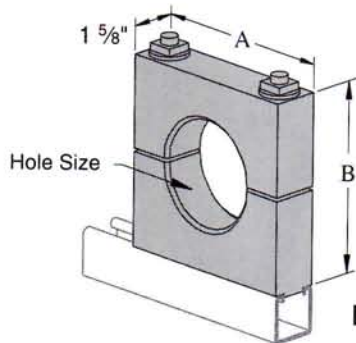

Inside Diameter Size	A & B	Wt./ 100 pcs
0"– 1"	3 1/2"	84
1"– 1 1/2"	4"	102
1 1/2"– 2"	4 1/2"	121
2"– 2 1/2"	5 1/2"	165
2 1/2"– 3"	6"	189
3"– 3 1/2"	6 1/2"	215
3 1/2"– 4"	7"	243

Use With: All 1 5/8" Wide Channels.  
 Assembly: Maple Part, 2 Stud Bolts, 2 Washers, 2 Clamping Nuts, 2 Square Nuts  
 NOTE: Special maple clamps can be made to order. Specify Cable Diameter.

**PS 1850 – Maple Bus Bar Clamp**

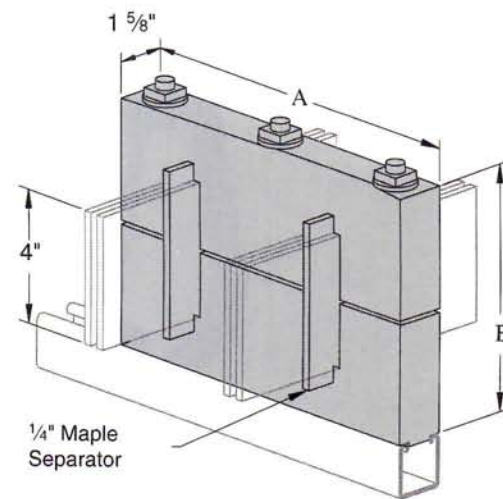

Type	Bus Bar Size	A	B	# of Separa- tors	Wt./ 100 pcs
1	1/4 x 2	8 1/2	5 3/8	0	360
2	1/4 x 2	9 1/2	5 3/8	2	400
3	1/4 x 2	10 1/2	5 3/8	4	430
4	1/4 x 2	11 1/2	5 3/8	6	460
5	1/4 x 2	12 1/2	5 3/8	8	490
6	1/4 x 2	13 1/2	5 3/8	10	520
1	1/4 x 4	8 1/2	7 3/8	0	421
2	1/4 x 4	9 1/2	7 3/8	2	465
3	1/4 x 4	10 1/2	7 3/8	4	509
4	1/4 x 4	11 1/2	7 3/8	6	553
5	1/4 x 4	12 1/2	7 3/8	8	597
6	1/4 x 4	13 1/2	7 3/8	10	631
1	1/4 x 6	8 1/2	9 3/8	0	567
2	1/4 x 6	9 1/2	9 3/8	2	628
3	1/4 x 6	10 1/2	9 3/8	4	689
4	1/4 x 6	11 1/2	9 3/8	6	750
5	1/4 x 6	12 1/2	9 3/8	8	811
6	1/4 x 6	13 1/2	9 3/8	10	872

Use With: All 1 5/8" Channels.  
 Assembly: Maple Part, 3 Stud Bolts, 3 Spring Nuts, 3 Square Nuts, 3 Washers

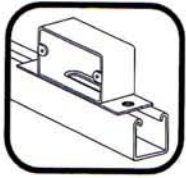

**General Information**

Finish: Electro-galvanized  
Order By: No. & Size



**PS 67 – Pipe or Conduit Hanger**

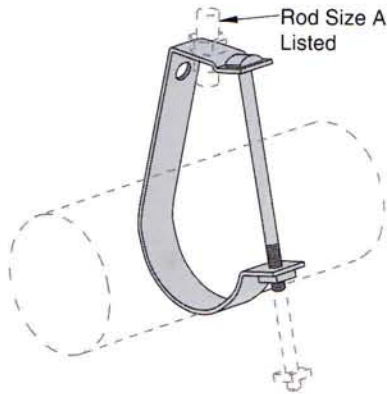

Conduit Size	A Rod Size	Load Rating	Wt./ 100 pcs
1/2"	3/8"	300	21
3/4"	3/8"	300	22
1"	3/8"	300	25
1 1/4"	3/8"	300	29
1 1/2"	3/8"	300	31
2"	3/8"	300	35
2 1/2"	3/8"	500	74
3"	1/2"	500	81
3 1/2"	1/2"	500	88
4"	5/8"	600	182
5"	5/8"	600	203
6"	3/4"	600	236

**PS 69 – E-Z Grip Hanger**

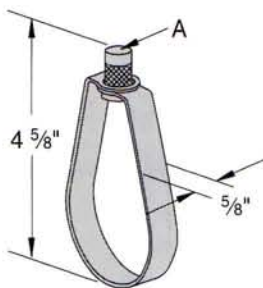

Size	A Rod Size	Load Rating Lbs/650	Wt./ 100 pcs
1/2"	3/8"	300	8
3/4"	3/8"	300	9
1"	3/8"	300	9
1 1/4"	3/8"	300	10
1 1/2"	3/8"	300	11
2"	3/8"	300	12
4"	3/8"	600	48
2 1/2"	3/8"	525	25
3"	3/8"	525	27
4"	3/8"	600	48

**PS 70 – E-Z Grip Hanger**

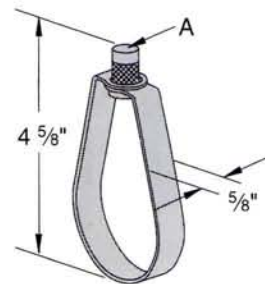

Size	A Rod Size	Load Rating Lbs/650	Wt./ 100 pcs
2 1/2"	1/2"	1000	33
3"	1/2"	1000	36
4"	5/8"	1100	56
5"	5/8"	1100	62
6"	3/4"	1250	120
8"	3/4"	1250	140



**General Information**

Finish: Electro-galvanized  
Order By: No. and Size

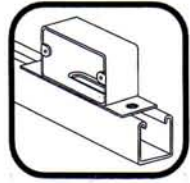

**PS 51 – Right Angle Pipe or Conduit Clamp**

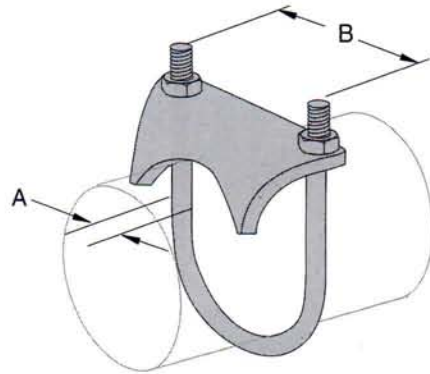

Size	A Diameter	B Diameter	Wt./ 100 pcs
3/8"	5/16"	15/16"	25
1/2"	5/16"	1 3/16"	41
3/4"	5/16"	1 7/16"	42
1"	5/16"	1 11/16"	47
1 1/4"	5/16"	2"	54
1 1/2"	5/16"	2 5/16"	57
2"	3/8"	2 3/16"	85
2 1/2"	3/8"	3 3/8"	106
3"	3/8"	4 1/8"	110
3 1/2"	3/8"	4 5/8"	128
4"	3/8"	5 1/8"	140

Material: Malleable Iron

**PS 270 – Conduit Clamp**



Size	A Diameter	Wt./ 100 pcs
3/8"	1/4"	6
1/2"	1/4"	6
3/4"	1/4"	8
1"	1/4"	9
1 1/4"	1/4"	11
1 1/2"	1/4"	19
2"	1/4"	27

**PS 52E – Parallel Pipe and Conduit Clamp**

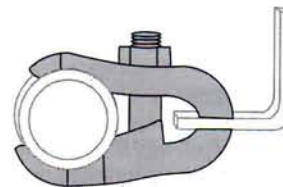

Size	Wt./ 100 pcs
1/2"	59
3/4"	64
1"	70
1 1/4"	72
1 1/2"	93
2"	128
2 1/2"	135
3"	155
3 1/2"	190
4"	205

Material: Malleable Iron

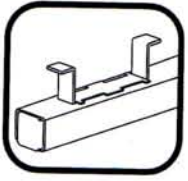

# CONCRETE INSERTS



## Materials & Manufacturing Specifications

### **GENERAL:**

A selection of heavy-duty to light-duty “continuous” and “spot” concrete inserts is available for use in pre-cast, pre-stressed or poured-in-place concrete floors, walls or ceilings.

### **MATERIAL:**

Power-Strut continuous slotted concrete inserts are cold formed from structural quality strip steel.

### **STANDARD LENGTHS:**

Standard lengths are 10 or 20 feet. Non-standard lengths from 3 inches to 20 feet are also available.

### **STANDARD FINISH:**

Power-Strut continuous-slotted concrete inserts are available in plain or pre-galvanized finishes. Closure strips (CS) are made of plastic and end caps (EC) are pre-galvanized.

### **ORDERING INFORMATION:**

When ordering, add the length or size and finish to the part number. See page 5 for finish abbreviations and an example.

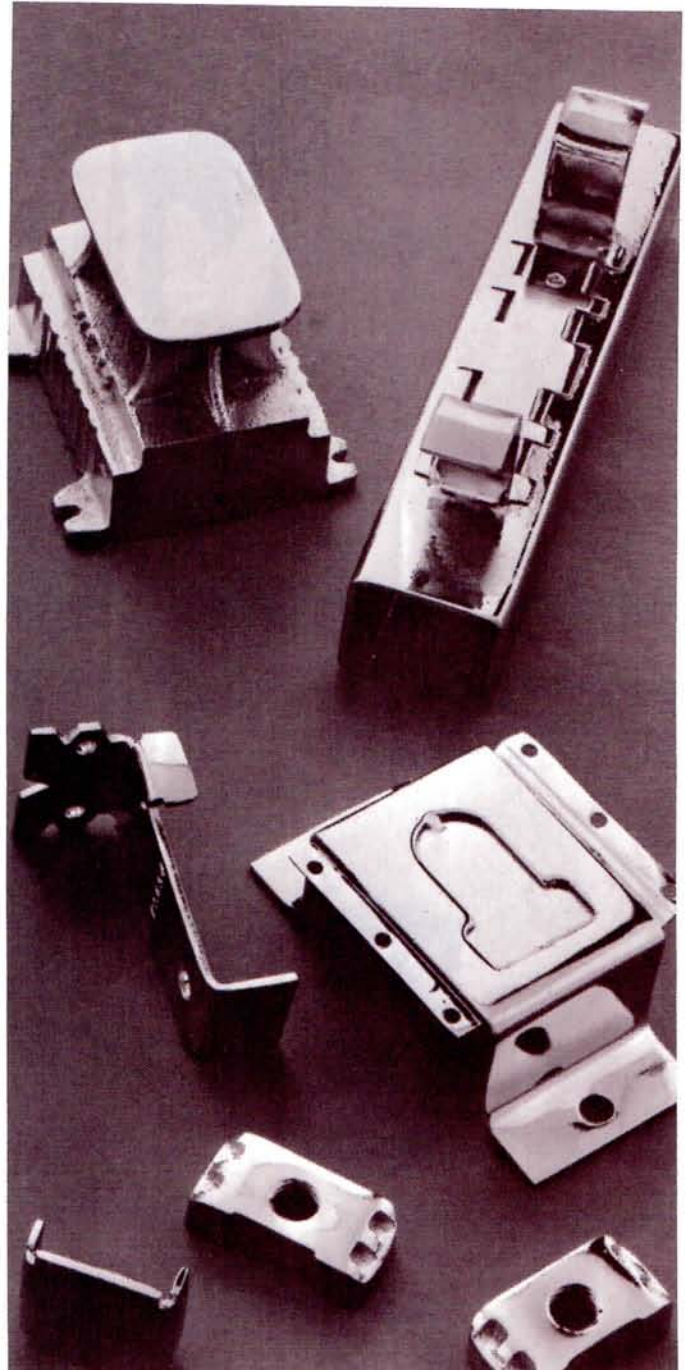



### General Information

Stock Thickness: .105 (12 ga.)  
 Finish: Plain, pre-galvanized or hot-dipped galvanized.  
 Stock Length: 20 feet; Other lengths made to order.  
 Order By: Part No. & Size

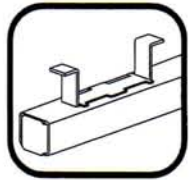

## PS 349 – Continuous Concrete Insert (1 5/8" x 1 3/8")

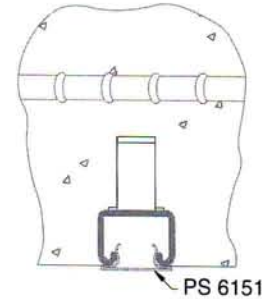
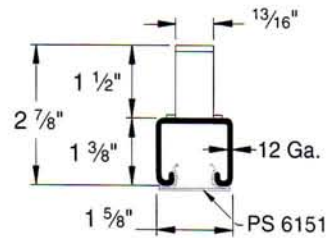
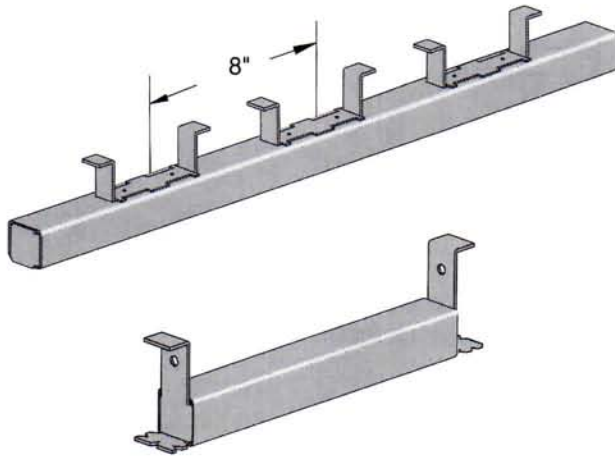

Choice of end cap is based on the distance from the end of the insert to the first anchor as shown below.

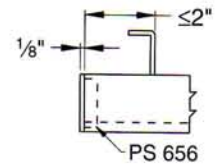
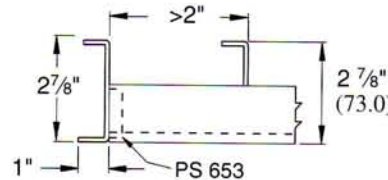

### Furnished with steel end caps and plastic closure strips installed

Part No.	End Cap	Wt./100 pcs		Load Data*
		PLN		
PS 349 3" CS/EC	PS 653	72		500 lbs
PS 349 4" CS/EC	PS 653	87		800 lbs.
PS 349 6" CS/EC	PS 653	117		1000 lbs.
PS 349 8" CS/EC	PS 653	147		1200 lbs.
PS 349 1' CS/EC	PS 653	194		2000 lbs.
PS 349 1'4" CS/EC	PS 656	253		2000 lbs./ft.
PS 349 1'8" CS/EC	PS 653	312		2000 lbs./ft.
PS 349 2' CS/EC	PS 656	371		2000 lbs./ft.
PS 349 2'8" CS/EC	PS 656	490		2000 lbs./ft.
PS 349 3' CS/EC	PS 653	549		2000 lbs./ft.
PS 349 4' CS/EC	PS 656	727		2000 lbs./ft.
PS 349 5' CS/EC	PS 653	905		2000 lbs./ft.
PS 349 6' CS/EC	PS 656	1082		2000 lbs./ft.
PS 349 7' CS/EC	PS 653	1260		2000 lbs./ft.
PS 349 8' CS/EC	PS 656	1438		2000 lbs./ft.
PS 349 9' CS/EC	PS 653	1615		2000 lbs./ft.
PS 349 10' CS/EC	PS 656	1793		2000 lbs./ft.
PS 349 12' CS/EC	PS 656	2148		2000 lbs./ft.
PS 349 14' CS/EC	PS 656	2504		2000 lbs./ft.
PS 349 16' CS/EC	PS 656	2859		2000 lbs./ft.
PS 349 18' CS/EC	PS 656	3215		2000 lbs./ft.
PS 349 20' CS/EC	PS 656	3570		2000 lbs./ft.
PS 349 10' W/O	Insert Only	1777		*uniform recommended loading
PS 349 20' W/O	Insert Only	3554		on inserts in 3,000 psi concrete.

- Use channel nuts designed for PS 300 Channel.
- Nail or anchor the inserts to forms every 16" to 24"

# CONCRETE INSERTS

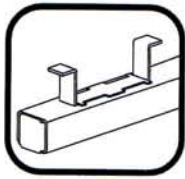

## General Information

Stock Thickness: .105 (12 ga.)  
 Finish: Plain, pre-galvanized or hot-dipped galvanized.  
 Stock Length: 20 feet; Other lengths made to order.  
 Order By: Part No. & Size



### PS 449 – Continuous Concrete Insert (1 5/8" x 1")

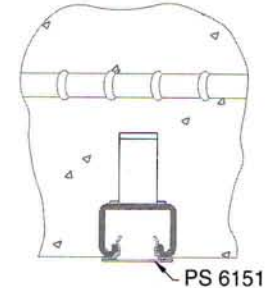
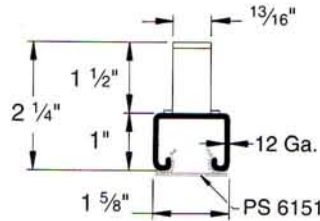
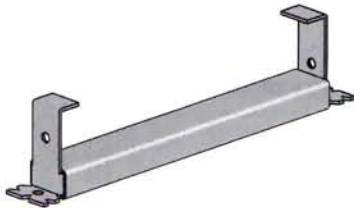
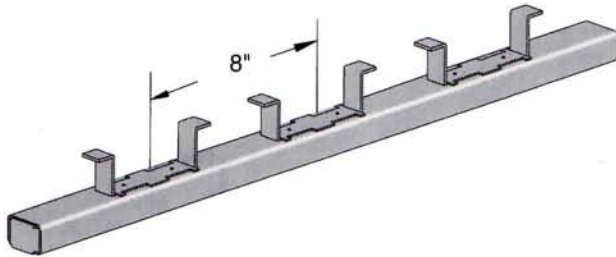

Choice of end cap is based on the distance from the end of the insert to the first anchor as shown below.

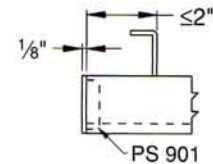
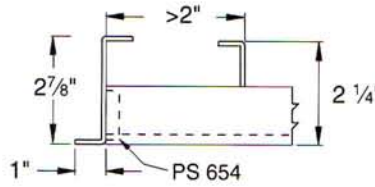

### Furnished with steel end caps and plastic closure strips installed

Part No.	End Cap	Wt./100 pcs		Load Data*
		PLN		
PS 449 3' CS/EC	PS 654	62		500 lbs
PS 449 4' CS/EC	PS 654	74		600 lbs.
PS 449 6' CS/EC	PS 654	99		800 lbs.
PS 449 8' CS/EC	PS 654	124		1000 lbs.
PS 449 1' CS/EC	PS 654	163		1600 lbs./ft.
PS 449 1'4" CS/EC	PS 901	213		1600 lbs./ft.
PS 449 1'8" CS/EC	PS 654	263		1600 lbs./ft.
PS 449 2' CS/EC	PS 901	313		1600 lbs./ft.
PS 449 2'8" CS/EC	PS 901	414		1600 lbs./ft.
PS 449 3' CS/EC	PS 654	464		1600 lbs./ft.
PS 449 4' CS/EC	PS 901	615		1600 lbs./ft.
PS 449 5' CS/EC	PS 654	766		1600 lbs./ft.
PS 449 6' CS/EC	PS 901	916		1600 lbs./ft.
PS 449 7' CS/EC	PS 654	1079		1600 lbs./ft.
PS 449 8' CS/EC	PS 901	1218		1600 lbs./ft.
PS 449 9' CS/EC	PS 654	1368		1600 lbs./ft.
PS 449 10' CS/EC	PS 901	1519		1600 lbs./ft.
PS 449 12' CS/EC	PS 901	1820		1600 lbs./ft.
PS 449 14' CS/EC	PS 901	2122		1600 lbs./ft.
PS 449 16' CS/EC	PS 901	2423		1600 lbs./ft.
PS 449 18' CS/EC	PS 901	2725		1600 lbs./ft.
PS 449 20' CS/EC	PS 901	3026		1600 lbs./ft.
PS 449 10' W/O	Insert Only	1507		* uniform recommended loading on inserts in 3,000 psi concrete.
PS 449 20' W/O	Insert Only	3014		

• Use channel nuts designed for PS 400 Channel.

• Nail or anchor the inserts to forms every 16" to 24"



**General Information**

Stock Thickness: .105 (12 ga.)  
 Finish: Electro-galvanized  
 Order By: Part No. & Size

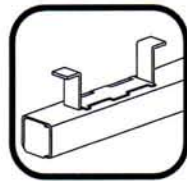

**PS 656, PS 901 – Type 'A' End Cap**



Part No.	Use With Insert	Finish	Wt./ 100 pcs
PS 656	PS 349	PGAL	8
PS 901	PS 449	PGAL	6

**PS 653 – Type 'B' End Cap**

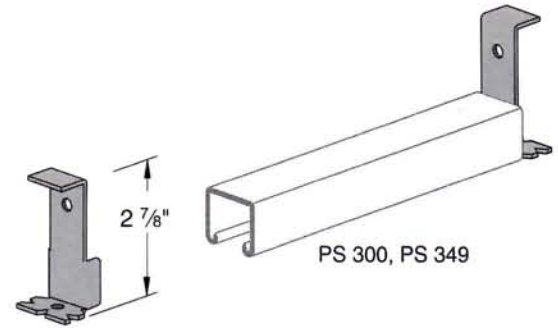

Finish: Pre-galvanized  
 Weight/100 pcs: 14 lbs.

**PS 654 – Type 'B' End Cap**

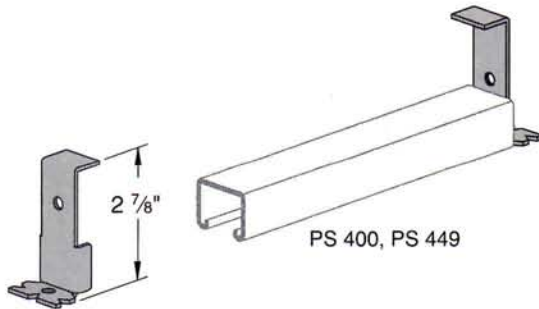

Finish: Pre-galvanized  
 Weight/100 pcs: 12 lbs.

**PS 1154 – Splice Connection**

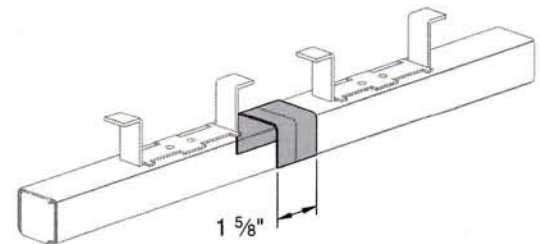

Weight/100 pcs: 10 lbs.  
 Use With: PS 349

**PS 6151 – Plastic Closure Strip**

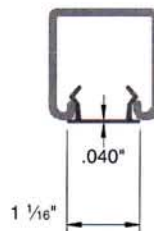

Material: Plastic  
 Stock Length: 10 ft.  
 Weight/100 pcs: 47 lbs.  
 Use With: All 1 5/8" channel and inserts

# CONCRETE INSERTS

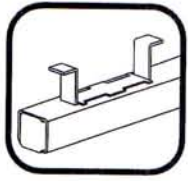

## General Information

Stock Thickness: .105 PGAL (12 ga.)  
Order By: No., Size & Finish



## PS 152 – Screw Concrete Insert

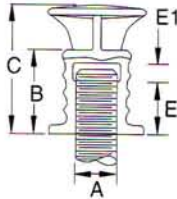
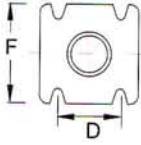
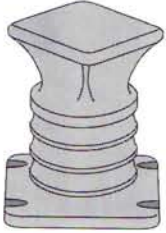

Material: Malleable iron.  
Finish: Black.

**ORDERING:** Specify rod size, figure number, name.

### loads • weights

Rod Size A	Max Pipe Size	Maximum Recommended Load	Weight (approx.) lbs. Each
3/8"	2"	610	0.31
1/2"	3 1/2"	1130	0.32
5/8"	5"	1260	0.37
3/4"	6"	2500	0.64
7/8"	12"	2500	0.71

### dimensions (inches)

Rod Size	A	B	C	D	E	E1	F
3/8"	1 1/32"	2 1/4"	2 1/4"	1"	1/2"	3/8"	1 5/8"
1/2"	1 1/32"	2 1/4"	2 1/4"	1"	1/2"	3/8"	1 5/8"
5/8"	1 7/32"	2 1/4"	2 1/4"	1"	5/8"	3/8"	1 5/8"
3/4"	1 5/8"	2 1/2"	2 1/2"	1 1/4"	15/16"	7/16"	2"

## PS 285 – Light Weight Concrete Insert

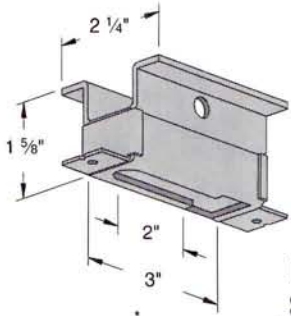

Rod Size	Load Rating	Wt./ 100 pcs
1/4"	230	46
3/8"	400	49
1/2"	400	49

Finish: Plain or Electro-galvanized

## PS 285 – Concrete Insert Nut

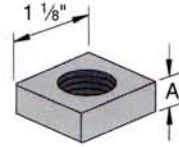

Part No.	Rod Size	A	Wt./ 100 pcs
PS 285	1/4"	3/16"	5
PS 285	3/8"	1/4"	8
PS 285	1/2"	5/16"	8
PS 285	5/8"	5/16"	7

Finish: Plain or Electro-galvanized

## PS 680 – Concrete Deck Insert

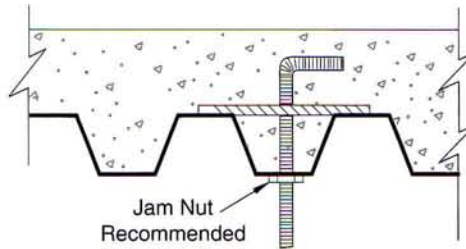
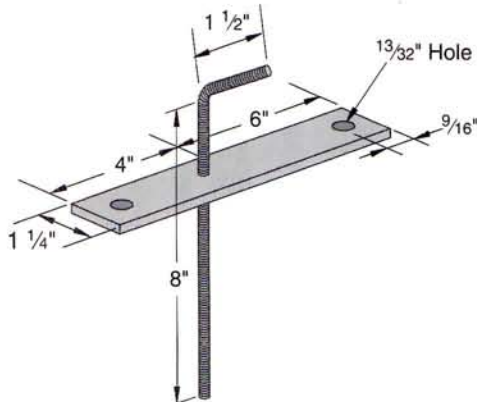

Part No.	Wt./ 100 pcs	Load Rating
PS 680-3/8"	86	610
PS 680-1/2"	105	1130
PS 680-5/8"	130	1810

Note: Rod is electro-galvanized and plate is plain.





## HEAVY DUTY CHANNEL



### Materials & Manufacturing Specifications

#### **GENERAL:**

Power-Strut channel sections are produced by multiple sets of forming rolls which cold-work strip steel into the channel configuration. This type of roll forming produces uniform channel sections held to the specifications of MFMA-1.

#### **MATERIAL:**

Channel is formed from structural quality strip steel which conforms to the requirements of ASTM A-570 Grade 33.

#### **STANDARD FINISH:**

PS 5000 is available in plain finish or hot-dip galvanized per ASTM A-123.

#### **ORDERING INFORMATION:**

When ordering, add the length or size and finish to the part number. See page 5 for finish abbreviations and an example.

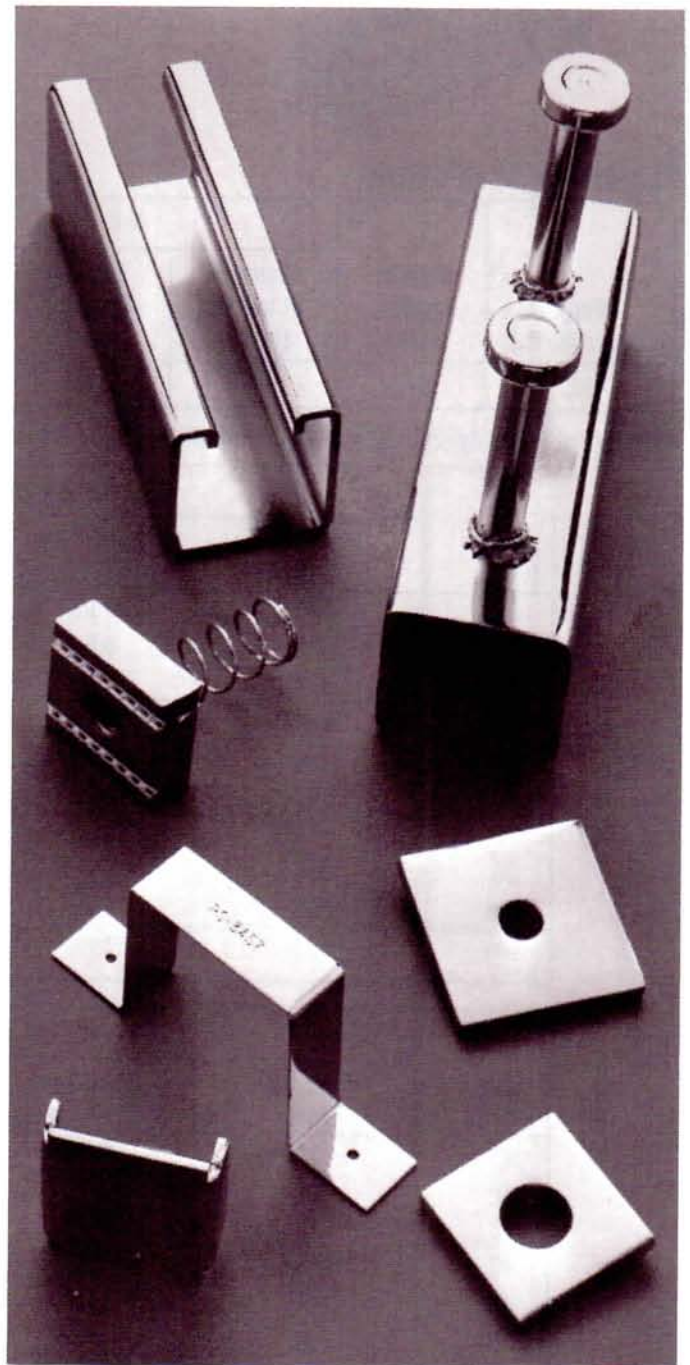

# HEAVY DUTY CHANNEL

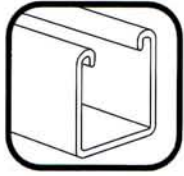

## General Information

Stock Thickness: .135" (10 ga.), ASTM A-570 Grade 33  
 Finish: Plain or hot-dipped galvanized  
 Stock Length: 10 and 20 feet, other lengths on request  
 Order By: No. & Finish



## PS 5000 – Heavy Duty Channel (2" x 2" x 10' Ga.)

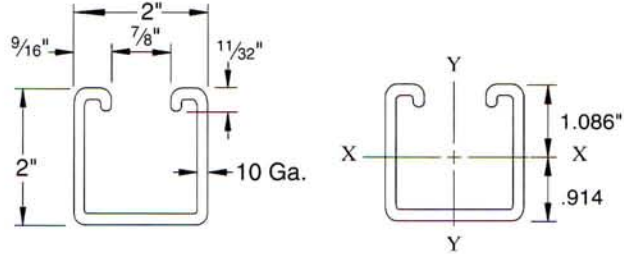

## ELEMENTS OF SECTION

Weight (lbs./100 ft.)	Area of Section (Inch <sup>2</sup> )	X-X Axis			Y-Y Axis		
		Moment of Inertia (Inch <sup>4</sup> )	Section Modulus (Inch <sup>3</sup> )	Radius of Gyration (Inch)	Moment of Inertia (Inch <sup>4</sup> )	Section Modulus (Inch <sup>3</sup> )	Radius of Gyration (Inch)
307	.912	.467	.428	.719	.561	.561	.789

Modulus of Elasticity: 29,000,000 PSI; \*Effective section properties

Span Inches	Uniform Loads			
	@ 25 KSI Stress	Deflection @ 25 KSI Stress	Deflection of 1/240 Span	Deflection of 1/360 Span
24	3651	0.05	3651	3651
30	2921	0.07	2921	2921
36	2425	0.11	2425	2302
42	2076	0.14	2076	1687
48	1813	0.19	1813	1288
60	1445	0.29	1233	817
72	1199	0.42	848	559
96	888	0.75	463	300
120	699	1.17	281	177
144	571	1.69	179	107

Span Inches	Concentrated Loads			
	@ 25 KSI Stress	Deflection @ 25 KSI Stress	Deflection of 1/240 Span	Deflection of 1/360 Span
24	1826	0.04	1826	1826
30	1461	0.06	1461	1461
36	1212	0.08	1212	1212
42	1038	0.12	1038	1038
48	907	0.15	907	806
60	723	0.24	723	512
72	599	0.34	532	352
96	444	0.60	292	191
120	350	1.94	180	115
144	286	1.35	117	72



### General Information

Stock Thickness: .135" (10 ga.), ASTM A-570 Grade 33  
 Finish: Plain or hot-dipped galvanized  
 Stock Length: 10 and 20 feet, other lengths on request  
 Order By: No., Size & Finish



## PS 5000 2T3 – Heavy Duty Channel (2" x 4" x 10' Ga.)

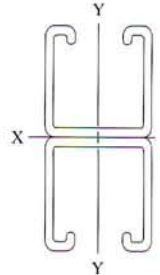
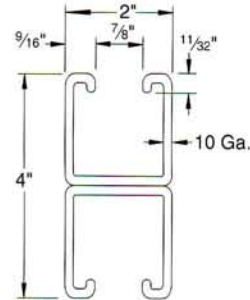
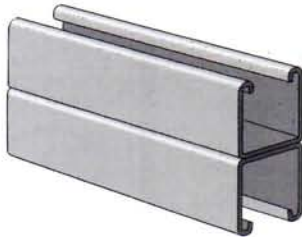

### ELEMENTS OF SECTION

Weight (lbs./100 ft.)	Area of Section (Inch <sup>2</sup> )	X-X Axis			Y-Y Axis		
		Moment of Inertia (Inch <sup>4</sup> )	Section Modulus (Inch <sup>3</sup> )	Radius of Gyration (Inch)	Moment of Inertia (Inch <sup>4</sup> )	Section Modulus (Inch <sup>3</sup> )	Radius of Gyration (Inch)
614	1.823	2.426	1.213	1.160	1.122	1.122	.789

Span Inches	Uniform Loads			
	@ 25 KSI Stress	Deflection @ 25 KSI Stress	Deflection of 1/240 Span	Deflection of 1/360 Span
36	6872	0.06	6872	6872
42	5890	0.08	5890	5890
48	5154	0.10	5154	5154
60	4123	0.16	4123	4123
72	3399	0.23	3399	2966
84	2902	0.31	2902	2163
96	2527	0.41	2485	1640
120	2000	0.64	1560	1019
144	1644	0.92	1052	676
180	1281	1.43	628	388

Span Inches	Concentrated Loads			
	@ 25 KSI Stress	Deflection @ 25 KSI Stress	Deflection of 1/240 Span	Deflection of 1/360 Span
36	3413	0.05	3413	3413
42	2922	0.06	2922	2922
48	2554	0.08	2554	2554
60	2038	0.13	2038	2038
72	1699	0.18	1699	1699
84	1451	0.25	1451	1357
96	1264	0.33	1264	1031
120	1000	0.51	983	645
144	822	0.73	667	432
180	641	1.15	404	254

# HEAVY DUTY CHANNEL ACCESSORIES



## General Information

Finish: Electro-galvanized  
 Use With: PS 5000  
 Order By: No., Size & Finish



### PS 3420 – End Cap



Stock Size: .105  
 Weight/100 pcs: 18 lbs.

### PS 3457 – Securing Strap

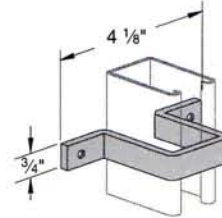

Stock Size: .046" (19 ga.)  
 Weight/100 pcs: 20 lbs.

### PS 3458 – Square Washer

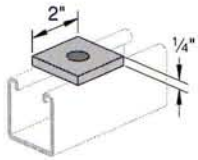

Bolt Size	Hole Size	Wt./100 pcs
1/2"	9/16"	27
5/8"	11/16"	26
3/4"	13/16"	25

### PS 3459 – Splice Plate

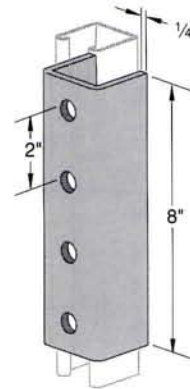

Weight/100 pcs: 345 lbs.

### PS 9227 – Clamping Nut

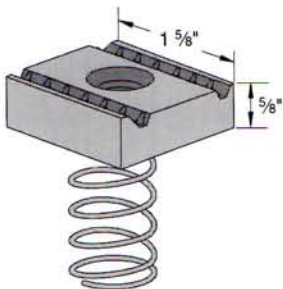

Size	Wt./100 pcs
1/2"	46
5/8"	45
3/4"	43



# JUNIOR CHANNEL

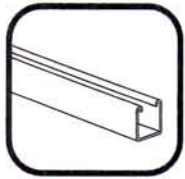

## Materials & Manufacturing Specifications

### **GENERAL:**

Power-Strut junior channel sections are cold formed from prime quality cold rolled steel. Junior channel fittings are punched from hot rolled, pickled and oiled steel.

### **STANDARD LENGTHS:**

Standard length is 10 feet at a tolerance of  $\pm 1/16$  inches. Shorter lengths are available for a small cutting charge.

### **STANDARD DIMENSIONS FOR FITTINGS:**

Fitting Thickness: 1/8"  
Fitting Width: 13/16"  
Hole Diameter: 9/32"  
Hole Spacing: 1 1/16" on centers and 13/32" from end.

### **STANDARD FINISH:**

PS 600J and PS 700J junior channels are available in a galvanized or painted green finish. All junior channel fittings are available in electro-galvanized finish.

### **ORDERING INFORMATION:**

When ordering, add the length or size and finish to the part number. See page 5 for finish abbreviations and an example.

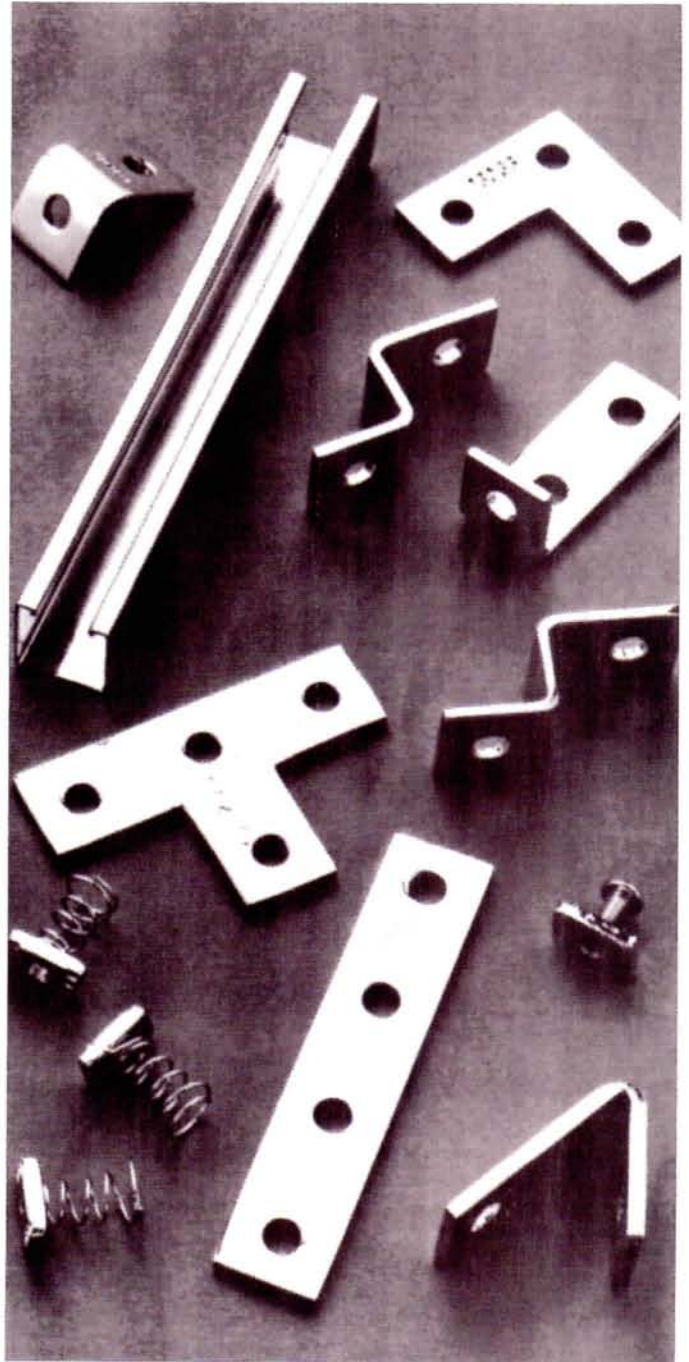

# JUNIOR CHANNEL

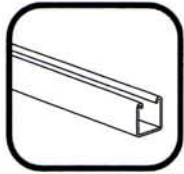

## General Information

Stock Thickness: .040 (19 ga.)  
 Finish: Pre-galvanized or painted green  
 Stock Length: 10 feet  
 Order By: No., Size & Finish



## PS 600J – Channel (13/16" x 13/16" x 19 ga.)

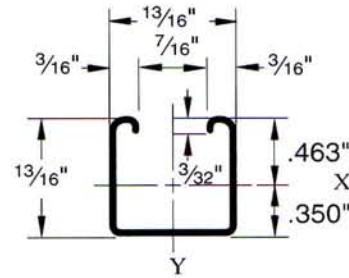

## PS 600J – Beam and Column Load Data

X-X Axis Span or Unbraced Column Height	Column Loads (lbs.)	Static Beam Load X-X Axis		
		Uniform Load (Lbs.) @25,000 PSI Stress	Deflection In. @ 25,000 PSI Stress	Uniform Load (Lbs.) @ Deflection of 1/240 Span
12"	2200	330	0.03	530
18"	1030	220	0.06	220
24"	580	170	0.12	150
30"	370	130	0.17	90
36"	260	110	0.25	70
42"	190	100	0.36	50
48"	140	80	0.43	40
54"	–	75	0.58	30
60"	–	70	0.74	20
66"	–	60	0.85	19
72"	–	55	1.01	16

Column loads are for allowable axial loads and must be reduced for eccentric loading. For concentrated load at center of span, divide uniform load by 2 and multiply corresponding deflection by 0.8.

## ELEMENTS OF SECTION

Weight (lbs./100 ft.)	Area of Section (Inch <sup>2</sup> )	X-X Axis			Y-Y Axis		
		Moment of Inertia (Inch <sup>4</sup> )	Section Modulus (Inch <sup>3</sup> )	Radius of Gyration (Inch)	Moment of Inertia (Inch <sup>4</sup> )	Section Modulus (Inch <sup>3</sup> )	Radius of Gyration (Inch)
37	0.105	.009	.020	.294	.012	.029	.333



**General Information**

Stock Thickness: .040 (19 ga.)  
 Finish: Pre-galvanized or painted green  
 Stock Length: 10 feet  
 Order By: Part No., Size & Finish



**PS 700J** – Channel (13/16" x 13/32" x 19 ga.)

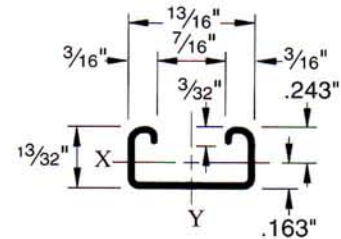

**PS 700J – Beam and Column Load Data**

X-X Axis	Span or Unbraced Column Height	Column Loads (lbs.)	Uniform Load (Lbs.) @25,000 PSI Stress	Static Beam Load X-X Axis	
				Deflection In. @ 25,000 PSI Stress	Uniform Load (Lbs.) @ Deflection of 1/240 Span
	12"	115	0.04	115	600
	18"	80	0.1	60	500
	24"	60	0.18	30	280
	30"	48	0.29	20	–
	36"	40	0.41	15	–

Column loads are for allowable axial loads and must be reduced for eccentric loading. For concentrated load at center of span, divide uniform load by 2 and multiply corresponding deflection by 0.8.

**ELEMENTS OF SECTION**

Weight (lbs./100 ft.)	Area of Section (Inch <sup>2</sup> )	X-X Axis			Y-Y Axis		
		Moment of Inertia (Inch <sup>4</sup> )	Section Modulus (Inch <sup>3</sup> )	Radius of Gyration (Inch)	Moment of Inertia (Inch <sup>4</sup> )	Section Modulus (Inch <sup>3</sup> )	Radius of Gyration (Inch)
26	0.078	0.0017	0.0073	0.15	0.0017	0.0073	0.15

# JUNIOR CHANNEL FITTINGS

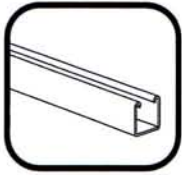

General Information  
 Stock Width: 13/16"  
 Stock Thickness: 1/8"  
 Finish: Electro-galvanized  
 Hole Diameter: 9/32"  
 Hole Spacing: 13/32" from end, 1 1/16" on center  
 Order By: Part No. & Size



## PS 3017 – Junior Channel Nuts



Size	Wt./ 100 pcs
8-32	1
10-32	1
10-24	1
1/4"	1

Use With: PS 600J channel

## PS 2013 – Square Washer

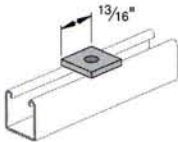

Weight/100 pcs: 2 lbs.

## PS 2015 – Three-Hole Splice Plate

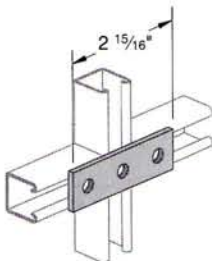

Weight/100 pcs: 8 lbs.

## PS 4017 – Junior Channel Nuts



Size	Wt./ 100 pcs
8-32	1
10-32	1
10-24	1
1/4"	1

Use With: PS 700J channel

## PS 2014 – Two-Hole Splice Plate

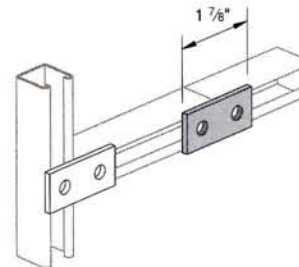

Weight/100 pcs: 5 lbs.

## PS 2016 – Four-Hole Splice Plate

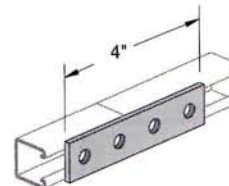

Weight/100 pcs: 11 lbs.





# JUNIOR CHANNEL FITTINGS

General Information  
 Stock Width: 13/16"  
 Stock Thickness: 1/8"  
 Finish: Electro-galvanized  
 Hole Diameter: 9/32"  
 Hole Spacing: 13/32" from end, 1 1/16" on center  
 Order By: Part No. & Size

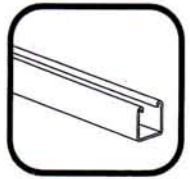

## PS 2033 – Flat Angle Plate

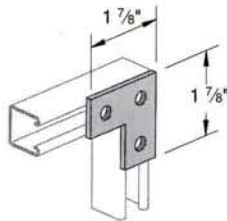

Weight/100 pcs: 8 lbs.

## PS 2034 – Tee Plate

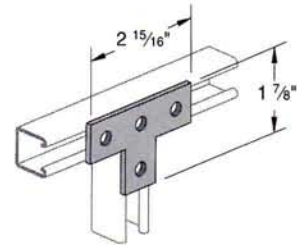

Weight/100 pcs: 11 lbs.

## PS 2008 – Two-Hole Corner Angle

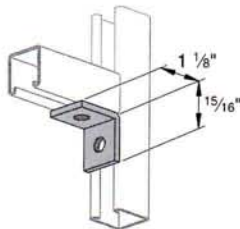

Weight/100 pcs: 5 lbs.

## PS 2017 – Two-Hole Corner Angle

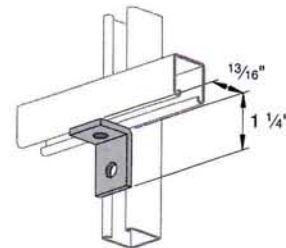

Weight/100 pcs: 5 lbs.

## PS 2018 – Three-Hole Corner Angle

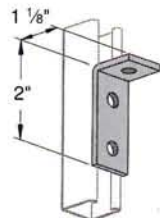

Weight/100 pcs: 8 lbs.

## PS 2025 – Three-Hole Corner Angle

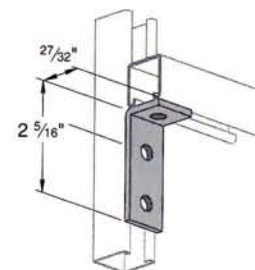

Weight/100 pcs: 8 lbs.

# JUNIOR CHANNEL FITTINGS

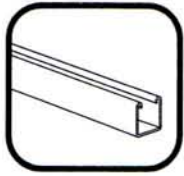

General Information  
 Stock Width: 13/16"  
 Stock Thickness: 1/8"  
 Finish: Electro-galvanized  
 Hole Diameter: 9/32"  
 Hole Spacing: 13/32" from end, 1 1/16" on center  
 Order By: No. & Size



## PS 2037 – Three-Hole Corner Angle

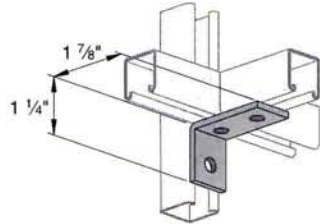

Weight/100 pcs: 8 lbs.

## PS 2019 – Four-Hole Corner Angle

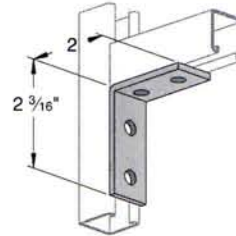

Weight/100 pcs: 11 lbs.

## PS 2024 – Four-Hole Corner Angle

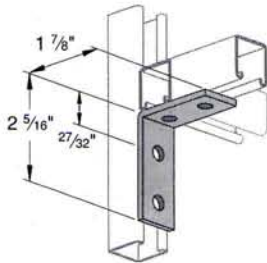

Weight/100 pcs: 11 lbs.

## PS 2023 R or L – Four-Hole Shelf Bracket

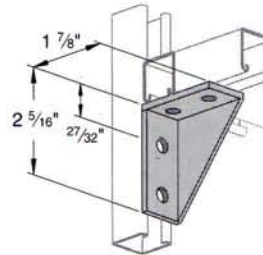

Weight/100 pcs: 19 lbs.

Note: Specify R (right) or L (left) when ordering  
*Right Hand Illustrated*

## PS 2010 – Zee Support

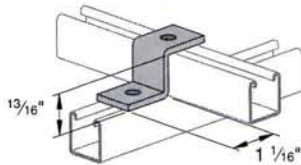

Weight/100 pcs: 7 lbs.

Use With: PS 600J

## PS 2026 – Zee Support

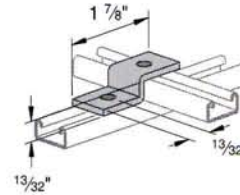

Weight/100 pcs: 6 lbs.

Use With: PS 700J



## JUNIOR CHANNEL FITTINGS

### General Information

Stock Width: 13/16"

Stock Thickness: 1/8"

Finish: Electro-galvanized

Hole Diameter: 9/32"

Hole Spacing: 13/32" from end, 1 1/16" on center

Order By: No. & Size

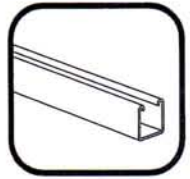

### PS 2011 – "U" Support

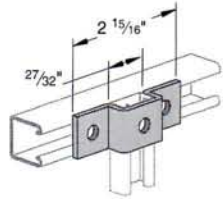

Weight/100 pcs: 12 lbs.

Use With: PS 600J

### PS 2029 – End Cap



Weight/100 pcs: 2 lbs.

Use With: PS 600J

### PS 2041 – Tubing Clamps

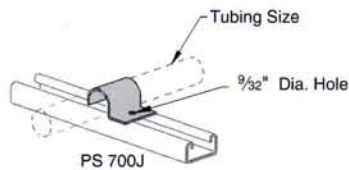

Size Tubing O.D.	Wt./ 100 pcs
1/4"	2
3/8"	2
1/2"	2
5/8"	2
3/4"	3
7/8"	3
1"	3

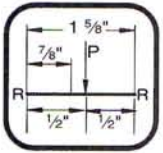

# TECHNICAL DATA

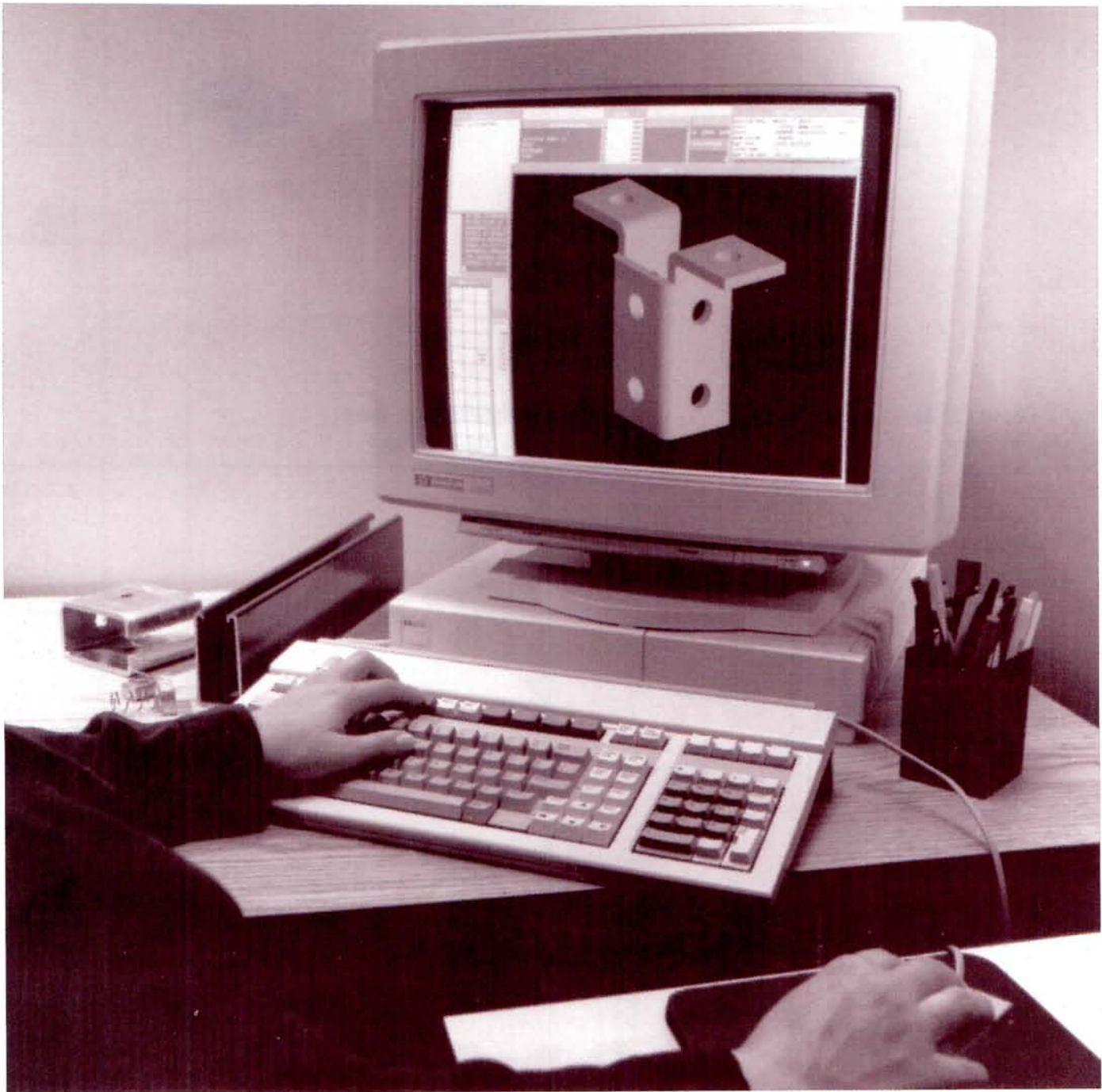

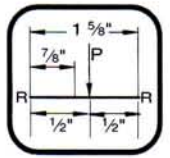

DESIGN LOAD DATA FOR POWER-STRUT CHANNEL CONNECTIONS

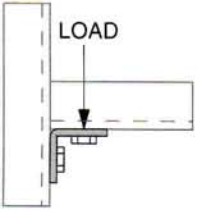
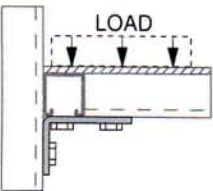
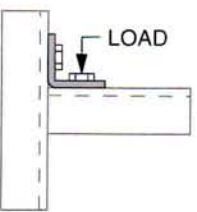
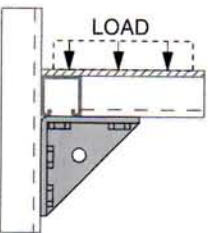
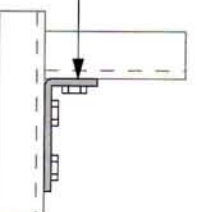
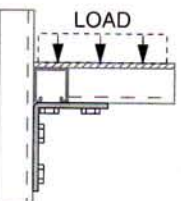
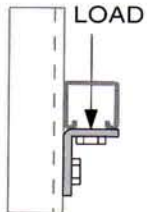
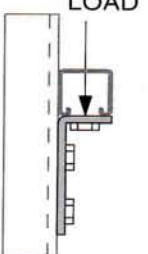
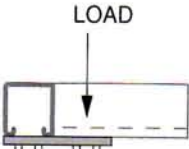
<p><b>PS 603</b> – PS-200 1500# PS-210 1000#</p>  <p>Both Ends Supported</p>	<p><b>PS 605</b> – PS-200 1500# PS-210 1000#</p>  <p>Both Ends Supported</p>
<p><b>PS 603</b> – PS-200 1000# PS-210 650#</p>  <p>Both Ends Supported</p>	<p><b>PS 3373</b> – PS-200 3000# PS-210 2000#</p>  <p>Both Ends Supported</p>
<p><b>PS 745</b> – PS-200 2000# PS-210 1500#</p>  <p>Both Ends Supported</p>	<p><b>PS 607</b> – PS-200 2000# PS-210 2000#</p>  <p>Both Ends Supported</p>
<p><b>PS 604</b> – 500#      <b>PS 606</b> – 500#</p>   <p>Both Ends Supported</p>	<p>PS-200 1000# PS-210 800#</p>  <p>Both Ends Supported</p>

- 1.) Safety Factor = 2-1/2 based on ultimate strength of connection.
- 2.) Load Diagrams indicate design loads for 12 ga. (listed as PS-200) and for 14 ga. (listed as PS-210) channels.

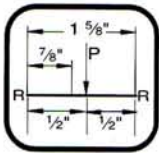

The information presented below is a direct reproduction from portions of the 8th Edition of **THE MANUAL OF STEEL CONSTRUCTION** by express permission of the American Institute of Steel Construction.



## Beam Diagrams and Formulas

### Nomenclature

E	Modulus of Elasticity of steel at 29,000 ksi.
I	Moment of Inertia of Beam (inch <sup>4</sup> ).
M <sub>max</sub>	Maximum Moment (kip inch)
M <sub>1</sub>	Maximum moment in left section of beam (kip inch)
M <sub>2</sub>	Maximum moment in right section of beam (kip inch)
M <sub>x</sub>	Moment at distance x from end of beam (kip inch)
P	Concentrated Load (kips)
R	End beam reaction for any condition of symmetrical loading (kips)
R <sub>1</sub>	Left end beam reaction (kips)
R <sub>2</sub>	Right end or intermediate beam reaction (kips)
V	Maximum vertical shear for any condition of symmetrical loading (kips)
V <sub>1</sub>	Maximum vertical shear in left section of beam (kips)
V <sub>2</sub>	Vertical shear at right reaction point, or to left of intermediate reaction point of beam (kips)
V <sub>x</sub>	Vertical shear at distance x from end of beam (kips)
a	Measured distance along beam (inch)
b	Measured distance along beam which may be greater or less than "a" (inch)
L	Total length of beam between reaction points (inch)
W	Uniformly distributed load per unit of length (kips per in.)
x	Any distance measured along beam from left reaction (inch)
x <sub>1</sub>	Any distance measured along overhang section of beam from nearest reaction point (in).
Δ <sub>max</sub>	Maximum deflection (inch)
Δ <sub>a</sub>	Deflection at point of load (inch)
Δ <sub>x</sub>	Deflection at point x distance from left reaction (inch)

### BEAM DIAGRAMS AND FORMULAS

*For various static loading conditions*

## CANTILEVER BEAMS

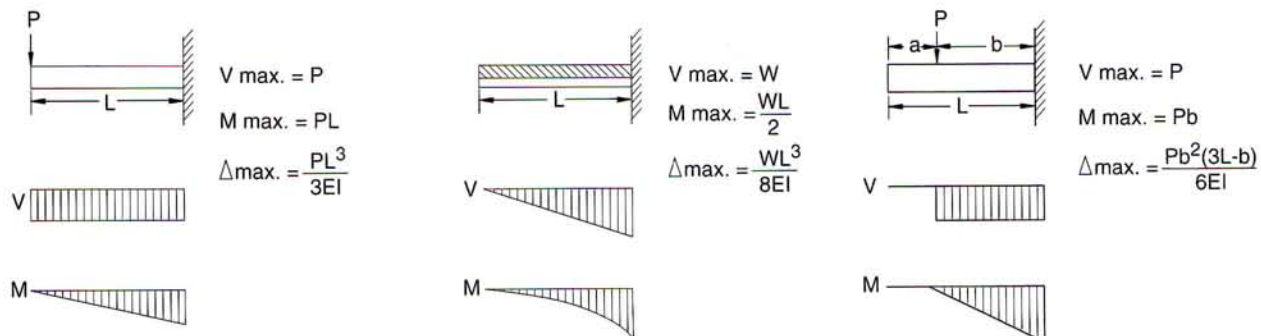



The information presented below is a direct reproduction from portions of the 8th Edition of THE MANUAL OF STEEL CONSTRUCTION by express permission of the American Institute of Steel Construction.

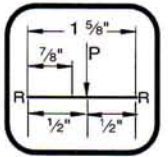

**BEAM DIAGRAMS AND FORMULAS**

*For various static loading conditions*

**SIMPLE BEAMS**

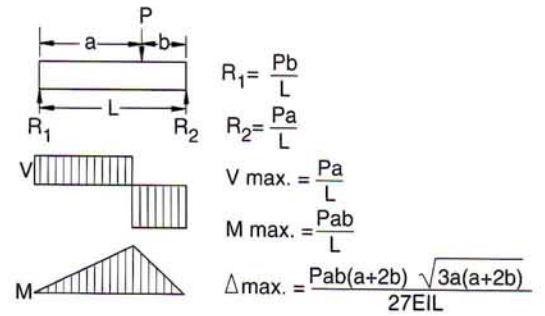
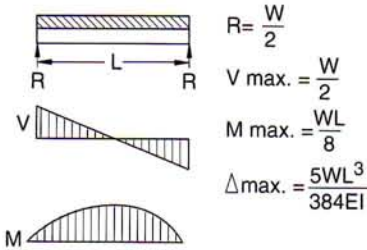
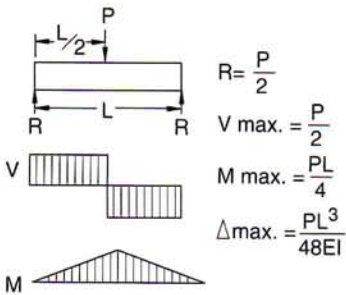

**BEAMS FIXED AT ONE END, SUPPORTED AT OTHER**

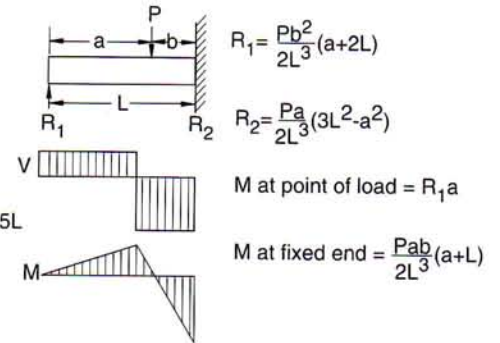
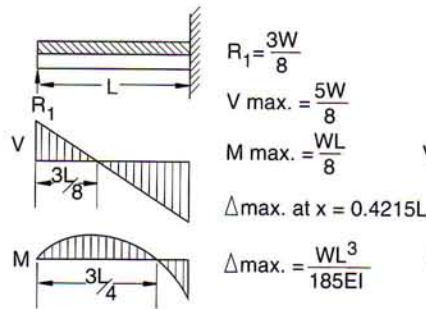
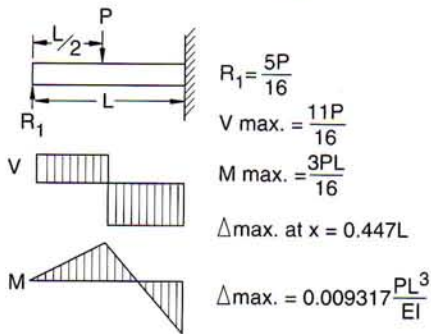

**BEAMS FIXED AT BOTH ENDS**

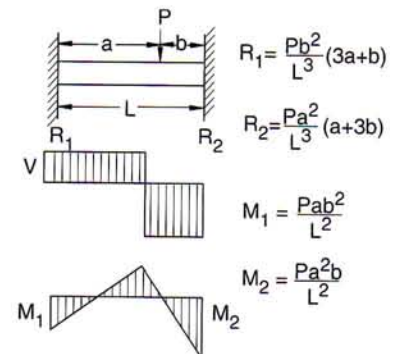
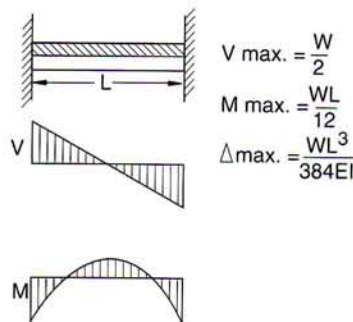
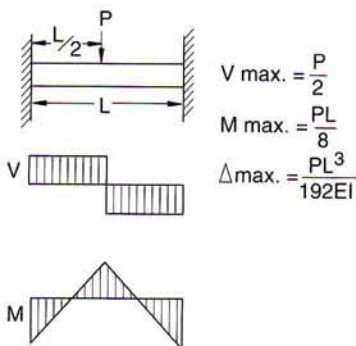





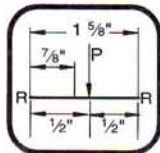





**MINIMUM SIZE POWER-STRUT CHANNEL  
TO COMPLY WITH NFPA 13 TABLE 2-6.1 5(a) 1994 EDITION**

Channel Size	Sect. Mod. (in <sup>3</sup> )
 <b>PS-200</b> 1 5/8" x 1 5/8" x 12 ga.	.202
 <b>PS-150</b> 1 5/8" x 2 7/16" x 12 ga.	.391
 <b>PS-100</b> 1 5/8" x 3 1/4" x 12 ga.	.628

Channel Size	Sect. Mod. (in <sup>3</sup> )
 <b>PS-150 2T3</b> 1 5/8" x 4 7/8" x 12 ga.	1.153
 <b>PS-100 2T3</b> 1 5/8" x 6 1/2" x 12 ga.	1.716

**Section Modulus Required for Trapeze Members (in.<sup>3</sup>)**

Span of Trapeze	Pipe Size											
	1"	1 1/4"	1 1/2"	2"	2 1/2"	3"	3 1/2"	4"	5"	6"	8"	10"
1 ft. 6 in.	0.08	0.09	0.09	0.09	0.10	0.11	0.12	0.13	0.15	0.18	0.24	0.32
	0.08	0.09	0.09	0.10	0.11	0.12	0.13	0.15	0.18	0.22	0.30	0.41
2 ft. 0 in.	0.11	0.12	0.12	0.13	0.13	0.15	0.16	0.17	0.20	0.24	0.32	0.43
	0.11	0.12	0.12	0.13	0.15	0.16	0.18	0.20	0.24	0.29	0.40	0.55
2 ft. 6 in.	0.14	0.14	0.15	0.16	0.17	0.18	0.20	0.21	0.25	0.30	0.40	0.54
	0.14	0.15	0.15	0.16	0.18	0.21	0.22	0.25	0.30	0.36	0.50	0.68
3 ft. 0 in.	0.17	0.17	0.18	0.19	0.20	0.22	0.24	0.26	0.31	0.36	0.48	0.65
	0.17	0.18	0.18	0.20	0.22	0.25	0.27	0.30	0.36	0.43	0.60	0.82
4 ft. 0 in.	0.22	0.23	0.24	0.25	0.27	0.29	0.32	0.34	0.41	0.48	0.64	0.87
	0.22	0.24	0.24	0.26	0.29	0.33	0.36	0.40	0.48	0.58	0.80	1.09
5 ft. 0 in.	0.28	0.29	0.30	0.31	0.34	0.37	0.40	0.43	0.51	0.59	0.80	1.08
	0.28	0.29	0.30	0.33	0.37	0.41	0.45	0.49	0.60	0.72	1.00	1.37
6 ft. 0 in.	0.33	0.35	0.36	0.38	0.41	0.44	0.48	0.51	0.61	0.71	0.97	1.30
	0.34	0.35	0.36	0.39	0.44	0.49	0.54	0.59	0.72	0.87	1.20	1.64
7 ft. 0 in.	0.39	0.40	0.41	0.44	0.47	0.52	0.55	0.60	0.71	0.83	1.13	1.52
	0.39	0.41	0.43	0.46	0.51	0.58	0.63	0.69	0.84	1.01	1.41	1.92
8 ft. 0 in.	0.44	0.46	0.47	0.50	0.54	0.59	0.63	0.68	0.81	0.95	1.29	1.73
	0.45	0.47	0.49	0.52	0.59	0.66	0.72	0.79	0.96	1.16	1.61	
9 ft. 0 in.	0.50	0.52	0.53	0.56	0.61	0.66	0.71	0.77	0.92	1.07	1.45	
	0.50	0.53	0.55	0.59	0.66	0.74	0.81	0.89	1.08	1.30	1.81	
10 ft. 0 in.	0.56	0.58	0.59	0.63	0.68	0.74	0.79	0.85	1.02	1.19	1.61	
	0.56	0.59	0.61	0.65	0.74	0.82	0.90	0.99	1.20	1.44		

Top values are for Schedule 10 pipe; bottom values are for Schedule 40 Pipe.

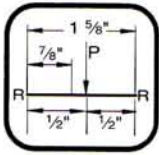

**CHANNELS – American Standard**

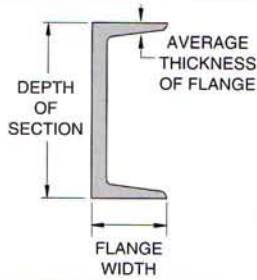

**I-BEAMS – American Standard**

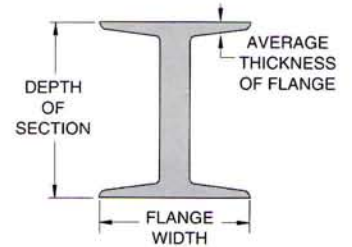

Depth of Section	Weight/Foot	Flange Width	Avg. Flange Thickness
3"	4.10	1 3/8"	0.273"
	5.00	1 1/2"	
	6.00	1 5/8"	
4"	5.40	1 5/8"	0.296"
	7.25	1 3/4"	
5"	6.70	1 3/4"	0.320"
	9.00	1 7/8"	
6"	8.20	1 7/8"	0.343"
	10.50	2"	
	13.00	2 1/8"	
7"	9.80	2 1/8"	0.366"
	12.25	2 1/4"	
	14.75	2 1/4"	
8"	11.50	2 1/4"	0.390"
	13.75	2 3/8"	
	18.75	2 1/2"	
9"	13.40	2 3/8"	0.413"
	15.00	2 1/2"	
	20.00	2 5/8"	
10"	15.30	2 5/8"	0.436"
	20.00	2 3/4"	
	25.00	2 7/8"	
	30.00	3"	
12"	20.70	3"	0.501"
	25.00	3"	
	30.00	3 1/8"	
15"	33.90	3 3/8"	0.650"
	40.00	3 1/2"	
	50.00	3 3/4"	
18"	42.70	4"	0.625"
	45.80	4"	
	51.90	4 1/8"	
	58.00	4 1/4"	

Depth of Section	Weight/Foot	Flange Width	Avg. Flange Thickness
3"	5.70	2 3/8"	0.260"
	7.50	2 1/2"	
4"	7.70	2 5/8"	0.293"
	9.50	2 3/4"	
5"	10.00	3"	0.326"
	14.75	3 1/4"	
6"	12.50	3 3/8"	0.359"
	17.25	3 5/8"	
7"	15.30	3 5/8"	0.392"
	20.00	3 7/8"	
	23.00	4"	
8"	18.40	4"	0.426"
	23.00	4 1/8"	
10"	25.40	4 5/8"	0.491"
	35.00	5"	
12"	31.80	5"	0.544"
	35.00	5 1/8"	
	40.80	5 1/4"	
15"	50.00	5 1/2"	0.659"
	42.90	5 1/2"	
	50.00	5 5/8"	
18"	54.70	6"	0.691"
	70.00	6 1/4"	
20"	66.00	6 1/4"	0.795"
	75.00	6 3/8"	
	86.00	7"	
	96.00	7 1/4"	
24"	80.00	7"	0.871"
	90.00	7 1/8"	
	100.00	7 1/4"	
	106.00	7 7/8"	
	121.00	8"	

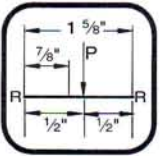

WIDE FLANGE BEAMS

Depth of Section	Wt/ Foot	Flange Width	Avg. Flange Thickness
5"	16	5"	0.360"
	19		0.430"
6"	12	4"	0.280"
	16	4"	0.405"
	20	6"	0.365"
	25		0.455"
8"	13	4"	0.255"
	15		0.315"
	18	5 1/4"	0.330"
	21		0.400"
	24	6 1/2"	0.400"
	28		0.465"
	31	8"	0.435"
	35		0.495"
	40	8 1/8"	0.560"
	48		0.685"
	58	8 1/4"	0.810"
	67		0.935"
	10"	15	4"
17			0.330"
19			0.395"
22		5 3/4"	0.360"
26			0.440"
30			0.510"
33		8"	0.435"
39			0.530"
45			0.620"
49		10"	0.560"
54			0.615"
60		10 1/8"	0.680"
68			0.770"
77		10 1/4"	0.870"
88			0.990"
100		10 3/8"	1.120"
112			1.250"
12"		16	4"
	19		0.350"
	22		0.425"
	26	6 1/2"	0.380"
	30		0.440"
	35	6 5/8"	0.520"
	40	8"	0.515"
	45		0.575"
	50	8 1/8"	0.640"
	53	10"	0.575"
	58		0.640"
	65	12"	0.605"
	72		0.670"
	79	12 1/8"	0.735"

Depth of Section	Wt/ Foot	Flange Width	Avg. Flange Thickness
12"	87		0.810"
	96		0.900"
	106	12 1/4"	0.990"
	120	12 3/8"	1.105"
	136		1.250"
	152	12 1/2"	1.400"
	190	12 5/8"	1.735"
14"	22	5"	0.335"
	26		0.420"
	30	6 3/4"	0.385"
	34		0.455"
	38		0.515"
	43	8"	0.530"
	48		0.595"
	53		0.660"
	61	10"	0.645"
	68		0.720"
	74	10 1/8"	0.785"
	82		0.855"
	90	14 1/2"	0.710"
	99	14 5/8"	0.780"
	109		0.860"
	120		0.940"
	132	14 3/4"	1.030"
	145	15 1/2"	1.090"
	159	15 5/8"	1.190"
	176		1.310"
193	15 3/4"	1.440"	
211		1.560"	
233	15 7/8"	1.720"	
257	16"	1.890"	
283	16 1/8"	2.070"	
311	16 1/4"	2.260"	
342	16 3/8"	2.470"	
370	16 1/2"	2.660"	
398	16 5/8"	2.845"	
426	16 3/4"	3.035"	
16"	26	5 1/2"	0.345"
	31		0.440"
	36	7"	0.430"
	40		0.505"
	45		0.565"
	50	7 1/8"	0.630"
	57		0.715"
	67	10 1/4"	0.665"
	77		0.760"
	89	10 3/8"	0.875"
	100		0.985"
	18"	35	6"

Depth of Section	Wt/ Foot	Flange Width	Avg. Flange Thickness	
18"	40		0.525"	
	46		0.605"	
	50	7 1/2"	0.570"	
	55		0.630"	
	60		0.695"	
	65	7 5/8"	0.750"	
	71		0.810"	
	76	11"	0.680"	
	86	11 1/8"	0.770"	
	97		0.870"	
	106	11 1/4"	0.940"	
	119		1.060"	
	21"	44	6 1/2"	0.450"
50			0.535"	
57			0.650"	
62		8 1/4"	0.615"	
68			0.685"	
73			0.740"	
83		8 3/8"	0.835"	
93			0.930"	
111		12 3/8"	0.875"	
122			0.960"	
147		12 1/2"	1.150"	
24"		55	7"	0.505"
		62		0.590"
		68	9"	0.585"
	76		0.680"	
	84		0.770"	
	94	9 1/8"	0.875"	
	104	12 3/4"	0.750"	
	117		0.850"	
	131	12 7/8"	0.960"	
	146		1.090"	
	162	13"	1.220"	
	27"	84	10"	0.640"
		94		0.745"
102			0.830"	
114		10 1/8"	0.930"	
146		14"	0.975"	
161			1.080"	
178		14 1/8"	1.190"	
30"	99	10 1/2"	0.670"	
	108		0.760"	
	116		0.850"	
	124		0.930"	
	132		1.000"	
	173	15"	1.065"	
	191		1.185"	
	211	15 1/8"	1.315"	

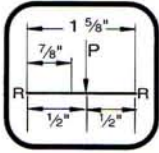

## TABLES OF PIPE SPACING

This chart, developed by Julius Getlan of Seelye Stevenson Value & Knecht, consulting engineers, New York City, enables one to quickly determine the centerline-to-centerline dimension between any two size pipes on a rack. Select the smaller pipe size at top and select the other at the side of the table. Where the appropriate columns intersect, the dimension is given.

These factors are included in the dimensions given:

- O.D. of flanges and fittings.
- 1" insulation over flanges and fittings.
- All fractional dimensions less than 1/4" were increased to the next larger 1/4".
- Clear space between fittings as follows:
  1. 1" between piping 3" and smaller.
  2. 1 1/2" between a pipe 3" and smaller and a pipe 4" or larger.
  3. 2" between piping 4" and larger.

### Centerline to Centerline Dimensions, Inches

		Normal Pipe Diameter, Inches															
		3/4"			1"			1 1/4"			1 1/2"						
		T	S		T	F	S	T	F	S	T	F	S				
Normal Pipe Diameter, Inches	3/4	T	4 3/4	—	—	—	—	—	—	—	—	—	—	—	—	—	—
		S	4 1/2	4 1/4	—	—	—	—	—	—	—	—	—	—	—	—	—
	1	T	5	4 3/4	5 1/4	—	—	—	—	—	—	—	—	—	—	—	—
		F	6	5 3/4	6 1/4	7 1/4	—	—	—	—	—	—	—	—	—	—	—
		S	4 3/4	4 1/2	5	6	4 1/2	—	—	—	—	—	—	—	—	—	—
	1 1/4	T	5 1/4	5	5 1/2	6 1/2	5	5 1/2	—	—	—	—	—	—	—	—	—
		F	6 1/4	6	6 1/2	7 1/2	6 1/4	6 3/4	7 3/4	—	—	—	—	—	—	—	—
		S	4 3/4	4 1/2	5	6	4 1/2	5 1/4	6 1/4	4 3/4	—	—	—	—	—	—	—
	1 1/2	T	5 1/4	5	5 1/2	6 1/2	5 1/4	5 3/4	6 3/4	5 1/4	5 3/4	—	—	—	—	—	—
		F	6 1/2	6 1/4	6 3/4	7 3/4	6 1/4	6 3/4	8	6 1/2	7	8	—	—	—	—	—
		S	5	4 3/4	5 1/4	6 1/4	4 3/4	5 1/4	6	5	5 1/2	6 1/2	5	—	—	—	—
	2	T	5 3/4	5 1/2	6	7	5 1/2	6	7 1/4	5 3/4	6 1/4	7 1/4	5 3/4	—	—	—	—
		F	7	6 3/4	7 1/4	8 1/4	6 3/4	7 1/4	8 1/2	7	7 1/2	8 1/2	7	—	—	—	—
		S	5 1/4	5	5 1/2	6 1/2	5	5 1/2	6 3/4	5 1/4	5 3/4	6 3/4	5 1/4	—	—	—	—
	2 1/2	T	6	5 3/4	6 1/4	7 1/4	6	6 1/2	7 1/2	6	6 1/2	7 3/4	6 1/4	—	—	—	—
		F	7 1/2	7 1/4	7 3/4	8 3/4	7 1/4	7 3/4	9	7 1/2	8	9	7 1/2	—	—	—	—
		S	5 1/2	5 1/4	5 3/4	6 3/4	5 1/4	5 3/4	7	5 1/2	6	7	5 1/2	—	—	—	—
	3	T	6 1/4	6	6 1/2	7 1/2	6 1/4	6 3/4	7 3/4	6 1/4	6 3/4	8	6 1/2	—	—	—	—
		F	7 3/4	7 1/2	8	9	7 1/2	8	9 1/4	7 3/4	8 1/4	9 1/4	7 3/4	—	—	—	—
		S	5 3/4	5 1/2	6	7	5 1/2	6	7 1/4	5 3/4	6 1/4	7 1/4	5 3/4	—	—	—	—
	4	T	7 1/2	7 1/4	7 3/4	8 3/4	7 1/4	7 3/4	9	7 1/2	8	9	7 1/2	—	—	—	—
		F	9	8 3/4	9 1/4	10 1/4	8 3/4	9 1/4	10 1/2	9	9 1/2	10 1/2	9	—	—	—	—
		S	6 3/4	6 1/2	7	8	6 1/2	7	8 1/4	6 3/4	7 1/4	8 1/4	6 3/4	—	—	—	—
	5	T	8	7 3/4	8 1/4	9 1/4	7 3/4	8 1/4	9 1/2	8	8 1/2	9 1/2	8	—	—	—	—
F		9 1/2	9 1/4	9 3/4	10 3/4	9 1/4	9 3/4	11	9 1/2	10	11	9 1/2	—	—	—	—	
S		7 1/4	7	7 1/2	8 1/4	7	7 1/2	8 3/4	7 1/4	7 3/4	8 3/4	7 1/4	—	—	—	—	
6	T	8 3/4	8 1/2	9	10	8 1/2	9	10 1/4	8 3/4	9 1/4	10 1/4	8 3/4	—	—	—	—	
	F	10	9 3/4	10 1/4	11 1/4	9 3/4	10 1/4	11 1/2	10	10 1/2	11 1/2	10	—	—	—	—	
	S	7 3/4	7 1/2	8	9	7 1/2	8	9 1/4	7 3/4	8 1/4	9 1/4	7 3/4	—	—	—	—	
8	T	8 3/4	9 1/2	10	11	9 3/4	10 1/2	11 1/4	9 3/4	10 1/4	11 1/2	10	—	—	—	—	
	F	11 1/4	11	11 1/2	12 1/2	11	11 1/2	12 3/4	11 1/4	11 3/4	12 3/4	11 1/4	—	—	—	—	
10	T	11 1/4	11	11 1/2	12 1/2	11	11 1/2	12 3/4	11 1/4	11 3/4	12 3/4	11 1/4	—	—	—	—	
	F	12 1/2	12 1/4	12 3/4	13 3/4	12 1/4	12 3/4	14	12 1/2	13	14	12 1/2	—	—	—	—	
12	T	12 1/4	12	12 1/2	13 1/2	12	12 1/2	13 3/4	12 1/4	12 3/4	13 3/4	12 1/4	—	—	—	—	
	F	14	13 3/4	14 1/4	15 1/4	13 3/4	14 1/4	15 1/2	14	14 1/2	15 1/2	14	—	—	—	—	

T denotes threaded IPS pipe. F denotes flanged fittings on pipe. S denotes soldered or brazed tubing.

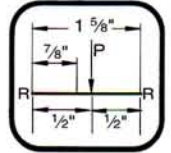

### Centerline to Centerline Dimensions, Inches

Nominal Pipe Dia. (In.)	Nominal Pipe Diameter, Inches												
	2"			2 1/2"			3"			4"			
	T	F	S	T	F	S	T	F	S	T	F	S	
2	T	6 1/2	-	-	-	-	-	-	-	-	-	-	
	F	7 3/4	9	-	-	-	-	-	-	-	-	-	
	S	6	7 1/4	5 1/2	-	-	-	-	-	-	-	-	
2 1/2	T	7	8 1/4	6 1/2	7 1/4	-	-	-	-	-	-	-	
	F	8 1/4	9 1/2	7 3/4	8 3/4	10	-	-	-	-	-	-	
	S	6 1/4	7 1/2	5 3/4	6 3/4	8	6	-	-	-	-	-	
3	T	7 1/4	8 1/2	6 3/4	7 1/2	9	7	7 3/4	-	-	-	-	
	F	8 1/2	9 3/4	8	9	10 1/4	8 1/4	9 1/4	10 1/2	-	-	-	
	S	6 1/2	7 3/4	6	7	8 1/4	6 1/4	7 1/4	8 1/2	6 1/2	-	-	
4	T	8 1/4	9 1/2	7 3/4	8 3/4	10	8	9	10 1/4	8 1/4	10	-	
	F	9 3/4	11	9 1/4	10 1/4	11 1/2	9 1/2	10 1/2	11 3/4	9 3/4	11 1/2	13	
	S	7 1/2	8 3/4	7	8	9 1/4	7 1/4	8 1/4	9 1/2	7 1/2	9 1/4	10 3/4	8 1/2
5	T	8 3/4	10	8 1/4	9 1/4	10 1/2	8 1/2	9 1/2	10 3/4	8 3/4	10 1/4	12	9 3/4
	F	10 1/4	11 1/2	9 3/4	10 3/4	12	10	11	12 1/4	10 1/4	12	13 1/2	11 1/4
	S	8	9 1/4	7 1/2	8 1/2	9 3/4	7 3/4	8 3/4	10	8	9 3/4	11 1/4	9
6	T	9 1/2	10 3/4	9	10	11 1/4	9 1/4	10 1/4	11 1/2	9 1/2	11 1/4	12 3/4	10 1/2
	F	10 3/4	12	10 1/4	11 1/4	12 1/2	10 1/2	11 1/2	12 1/4	10 3/4	12 1/2	14	11 3/4
	S	8 1/2	9 3/4	8	9	10 1/4	8 1/4	9 1/4	10 1/2	8 1/2	10 1/4	11 3/4	9 1/2
8	T	10 3/4	12	10 1/2	11	12 1/2	10 1/2	11 1/4	12 3/4	10 3/4	12 1/2	14	11 3/4
	F	12	13 1/4	11 1/2	12 1/2	13 3/4	11 3/4	12 3/4	14	12	13 3/4	15 1/4	13
	10	T	12	13 1/4	11 1/2	12 1/2	13 3/4	11 3/4	12 3/4	14	12	13 3/4	15 1/4
12	F	13 1/4	14 1/2	12 3/4	13 3/4	15	13	14	15 1/4	13 1/4	15	16 1/2	14 1/4
	T	13	14 1/4	12 1/2	13 1/2	14 3/4	12 3/4	13 3/4	15	13	14 3/4	16 1/4	14
	F	14 3/4	16	14 1/4	15 1/4	16 1/2	14 1/2	15 1/2	16 3/4	14 3/4	16 1/2	18	15 3/4

Nominal Pipe Dia. (In.)	Nominal Pipe Diameter, Inches												
	5"			6"			8"		10"		12"		
	T	F	S	T	F	S	T	F	T	F	T	F	
5	T	11	-	-	-	-	-	-	-	-	-	-	
	F	12 1/2	14	-	-	-	-	-	-	-	-	-	
	S	10 1/4	11 3/4	9 1/2	-	-	-	-	-	-	-	-	
6	T	11 3/4	13 1/4	11	12 1/2	-	-	-	-	-	-	-	
	F	13	14 1/2	12 1/4	13 1/4	15	-	-	-	-	-	-	
	S	10 3/4	12 1/4	10	11 1/2	12 3/4	10 1/2	-	-	-	-	-	
8	T	13	14 1/2	12 1/4	13 3/4	15	12 3/4	14 3/4	-	-	-	-	
	F	14 1/4	15 3/4	13 1/2	15	16 1/4	14	16 1/4	17 1/2	-	-	-	
	10	T	14 1/4	15 3/4	13 1/2	15	16 1/4	14	16 1/4	17 1/2	17 1/2	-	-
12	F	15 1/2	17	14 3/4	16 1/4	17 1/2	15 1/4	17 1/2	18 3/4	18 3/4	20	-	-
	T	15 1/4	16 3/4	14 1/2	16	17 1/4	15	17 1/4	18 1/2	18 1/2	19 3/4	19 1/2	-
	F	17	18 1/4	16 1/4	17 3/4	19	16 3/4	14	20 1/4	20 1/4	21 1/2	21 1/4	29

T denotes threaded IPS pipe. F denotes flanged fittings on pipe.

S denotes soldered or brazed tubing.

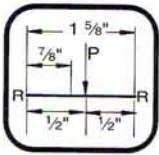

## ELECTRICAL METALLIC TUBING DATA

Nom. Size EMT Conduit	OD Conduit	Conduit Wt. lbs./ft	Approx. Max Wt. (lbs.ft.) Conduit and Conductor Not Lead Covered
1/2	0.706	0.29	0.54
3/4	0.922	0.45	1.16
1	1.163	0.65	1.83
1 1/4	1.510	0.96	2.96
1 1/2	1.740	1.11	3.68
2	2.197	1.41	4.45
2 1/2	2.875	2.15	6.41
3	3.500	2.60	9.30
3 1/2	4.000	3.25	12.15
4	4.500	3.90	15.40

## APPLICATION ENGINEERING DATA – Conduit Spacings

Spacings in inches between centers of conduits. The light face figures are the minimum dimensions to provide clearance between locknuts. The more liberal spacings printed in bold face type should be used whenever possible.

Size	Size												
	1/2	3/4	1	1 1/4	1 1/2	2	2 1/2	3	3 1/2	4	4 1/2	5	6
1/2	1 3/16 <b>1 3/8</b>	–	–	–	–	–	–	–	–	–	–	–	–
3/4	1 5/16 <b>1 1/2</b>	1 7/16 <b>1 5/8</b>	–	–	–	–	–	–	–	–	–	–	–
1	1 1/2 <b>1 3/4</b>	1 5/8 <b>1 7/8</b>	1 3/4 <b>2</b>	–	–	–	–	–	–	–	–	–	–
1 1/4	1 3/4 <b>2</b>	1 7/8 <b>1 1/8</b>	2 <b>2 1/4</b>	2 1/4 <b>2 1/2</b>	–	–	–	–	–	–	–	–	–
1 1/2	1 15/16 <b>2 1/8</b>	2 1/16 <b>2 1/4</b>	2 3/16 <b>2 3/8</b>	2 7/16 <b>2 5/8</b>	2 9/16 <b>2 3/4</b>	–	–	–	–	–	–	–	–
2	2 3/16 <b>2 3/8</b>	2 5/16 <b>2 1/2</b>	2 1/2 <b>2 3/4</b>	2 3/4 <b>3</b>	2 7/8 <b>3 1/8</b>	3 1/8 <b>3 3/8</b>	–	–	–	–	–	–	–
2 1/2	2 7/16 <b>2 5/8</b>	2 9/16 <b>2 3/4</b>	2 3/4 <b>3</b>	3 <b>3 1/4</b>	3 1/8 <b>3 3/8</b>	3 3/8 <b>3 5/8</b>	3 5/8 <b>4</b>	–	–	–	–	–	–
3	2 13/16 <b>3</b>	2 15/16 <b>3 1/8</b>	3 1/16 <b>3 3/8</b>	3 5/16 <b>3 5/8</b>	3 7/16 <b>3 3/4</b>	3 3/4 <b>4</b>	4 <b>4 3/8</b>	4 5/16 <b>4 3/4</b>	–	–	–	–	–
3 1/2	3 1/8 <b>3 3/8</b>	3 1/4 <b>3 1/2</b>	3 3/8 <b>3 5/8</b>	3 5/8 <b>3 7/8</b>	3 3/4 <b>4</b>	4 1/16 <b>4 3/8</b>	4 5/16 <b>4 5/8</b>	4 5/8 <b>5</b>	4 15/16 <b>5 3/8</b>	–	–	–	–
4	3 7/16 <b>3 3/4</b>	3 9/16 <b>3 7/8</b>	3 11/16 <b>4</b>	3 15/16 <b>4 1/4</b>	4 1/16 <b>4 3/8</b>	4 3/8 <b>4 3/4</b>	4 5/8 <b>5</b>	4 15/16 <b>5 3/8</b>	5 1/4 <b>5 5/8</b>	5 9/16 <b>6</b>	–	–	–
4 1/2	3 3/4 <b>4</b>	3 7/8 <b>4 1/8</b>	4 <b>4 1/4</b>	4 1/4 <b>4 1/2</b>	4 3/8 <b>4 3/4</b>	4 5/8 <b>5</b>	4 7/8 <b>5 1/4</b>	5 1/4 <b>5 5/8</b>	5 9/16 <b>6</b>	5 7/8 <b>6 1/4</b>	6 1/8 <b>6 1/2</b>	–	–
5	4 1/8 <b>4 3/8</b>	4 1/4 <b>4 1/2</b>	4 3/8 <b>4 5/8</b>	4 5/8 <b>4 7/8</b>	4 3/4 <b>5</b>	5 <b>5 3/8</b>	5 1/4 <b>5 5/8</b>	5 9/16 <b>6</b>	5 7/8 <b>6 1/4</b>	6 3/16 <b>6 5/8</b>	6 1/2 <b>7</b>	6 13/16 <b>7 1/4</b>	–
6	4 3/4 <b>5</b>	4 7/8 <b>5 1/8</b>	5 <b>5 1/4</b>	5 1/4 <b>5 1/2</b>	5 3/8 <b>5 5/8</b>	5 5/8 <b>6</b>	5 7/8 <b>6 1/4</b>	6 3/16 <b>6 5/8</b>	6 1/2 <b>7</b>	6 13/16 <b>7 1/4</b>	7 1/8 <b>7 5/8</b>	7 7/16 <b>8</b>	8 1/8 <b>8 5/8</b>

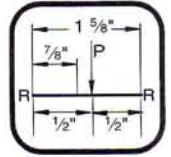

**STEEL RIGID CONDUIT DATA**

Nom. Size Rigid Conduit	OD Conduit	OD Coupling	Wt. Conduit W/C Pkg. lbs./ft	Approx. Max Wt. (lbs./ft.) Conduit and Conductor	
				Lead Covered	Not Lead Covered
1/2	0.840	1.010	0.80	1.17	1.04
3/4	1.050	1.250	1.09	1.75	1.40
1	1.315	1.525	1.65	2.62	2.35
1 1/4	1.660	1.869	2.15	4.31	3.58
1 1/2	1.900	2.155	2.58	5.89	4.55
2	2.375	2.650	3.52	8.53	7.21
2 1/2	2.875	3.250	5.67	11.51	10.22
3	3.500	3.870	7.14	16.51	14.51
3 1/2	4.000	4.500	8.60	19.05	17.49
4	4.500	4.875	10.00	24.75	21.48
5	5.563	6.000	13.20	35.87	30.83
6	6.625	7.200	17.85	50.69	43.43

Maximum weight equals weight of rigid conduit plus weight of heaviest conductor combination as specified by the 1996 edition of the "National Electric Code Handbook."

**INTERMEDIATE METAL CONDUIT DATA**

Nom. Size Rigid Conduit	OD Conduit	OD Coupling	Weight Conduit W/C Pkg. lbs./ft	Approx. Max Wt. (lbs./ft.) Conduit and Conductor	
				Lead Covered	Not Lead Covered
1/2	0.815	1.010	0.60	0.97	0.84
3/4	1.029	1.250	0.82	1.48	1.13
1	1.290	1.525	1.16	2.13	1.86
1 1/4	1.638	1.869	1.50	3.66	2.93
1 1/2	1.883	2.115	1.82	5.13	3.79
2	2.360	2.650	2.42	7.43	6.11
2 1/2	2.857	3.250	4.28	10.12	8.83
3	3.476	3.870	5.26	14.63	12.63
3 1/2	3.971	4.500	6.12	16.57	15.01
4	4.466	4.875	6.82	21.57	18.30

1 Cubic ft. of water weighs 62.35 lbs.

1 Gallon US weighs 8.335 lbs.

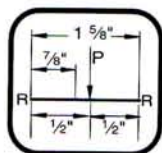

**STEEL PIPE DATA – Schedule 40 & 80**

Nominal Pipe Size	Sch. No.	O.D.	Wall Thick	Wt./Ft.	Wt. of Water/Ft
3/8	40	0.675	0.091	0.567	0.083
	80		0.126	0.738	0.061
1/2	40	0.840	0.109	0.850	0.132
	80		0.147	1.087	0.101
3/4	40	1.050	0.133	1.130	0.230
	80		0.154	1.473	0.186
1	40	1.315	0.133	1.678	0.374
	80		0.179	2.171	0.311
1 1/4	40	1.660	0.140	2.272	0.647
	80		0.199	2.996	0.555
1 1/2	40	1.900	0.145	2.717	0.882
	80		0.200	3.631	0.765
2	40	2.375	0.154	3.652	1.452
	80		0.218	5.022	1.279
2 1/2	40	2.875	0.203	5.790	2.072
	80		0.276	7.660	1.834
3	40	3.500	0.216	7.570	3.200
	80		0.300	10.250	2.860
3 1/2	40	4.000	0.226	9.110	4.280
	80		0.318	12.510	3.850
4	40	4.500	0.237	10.790	5.510
	80		0.337	14.980	4.980
5	40	5.563	0.258	14.620	8.660
	80		0.375	20.780	7.870
6	40	6.625	0.280	18.970	12.510
	80		0.432	28.570	11.290
8	40	8.625	0.322	28.550	21.600
	80		0.500	43.390	19.800
10	40	10.750	0.365	40.480	34.100
	80		0.593	64.400	31.100
12	40	12.750	0.406	53.600	48.500
	80		0.687	88.600	44.000
14	40	14.000	0.437	63.000	58.500
	80		0.750	107.000	51.200
16	40	16.000	0.500	83.000	76.500
	80		0.843	137.000	69.700
18	40	18.000	0.563	105.000	97.200
	80		0.937	171.000	88.500
20	40	20.000	0.593	123.000	120.400
	80		1.031	209.000	109.400
24	40	24.000	0.687	171.000	174.200
	80		1.218	297.000	158.200
30	20	30.000	0.500	158.000	286.000
36	API	36.000	0.500	190.000	417.000



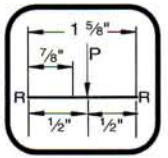

**SPACING OF HANGERS FOR STEEL PIPE**

<b>Nominal Pipe Size, Inches</b>	1/2	3/4	1	1 1/4	1 1/2	2	2 1/2	3	3 1/2	4	5	6	8	10	12	14	16	18	20	24
<b>Maximum Span, Ft.*</b>	5	6	7	7	9	10	11	12	13	14	16	17	19	2	23	25	27	28	30	32
<b>Recommended Hanger Rod Sizes</b>	3/8	3/8	3/8	3/8	3/8	3/8	1/2	1/2	1/2	5/8	5/8	3/4	7/8	7/8	7/8	1	1	1 1/4	1 1/2	or Trapeze

The above spacing and capacities are based on pipe filled with water. Additional valves and fittings increase the load and therefore closer hanger spacing is required.

\*Many codes and specifications state "pipe hangers must be spaced every 10 ft., regardless of size". Follow local specifications.

**COPPER TUBE DATA**

**Type L**

Nom. Tube Size	O.D. Tubing	O.D.	Wall Thick	Wt./Ft. Lbs.	Wt. of Water/Ft. Lbs.
1/4	3/8	0.375	0.030	0.126	0.034
3/8	1/2	0.500	0.035	0.198	0.062
1/2	5/8	0.625	0.040	0.285	0.100
5/8	3/4	0.750	0.042	0.362	0.151
3/4	7/8	0.875	0.045	0.455	0.209
1	1 1/8	1.125	0.050	0.655	0.357
1 1/4	1 3/8	1.375	0.055	0.884	0.546
1 1/2	1 5/8	1.625	0.060	1.140	0.767
2	2 1/8	2.125	0.070	1.750	1.341
2 1/2	2 5/8	2.625	0.080	2.480	2.064
3	3 1/8	3.125	0.090	3.330	2.949
3 1/2	3 5/8	3.625	0.100	4.290	3.989
4	4 1/8	4.125	0.110	5.380	5.188
5	5 1/8	5.125	0.125	7.610	8.081
6	6 1/8	6.125	0.140	10.200	11.616
8	8 1/8	8.125	0.200	19.290	20.289
10	10 1/8	10.125	0.250	30.100	31.590
12	12 1/8	12.125	0.280	40.400	45.426

**Type K**

Nom. Tube Size	O.D. Tubing	O.D.	Wall Thick	Wt./Ft. Lbs.	Wt. of Water/Ft. Lbs.
1/4	3/8	0.375	0.035	0.145	0.032
3/8	1/2	0.500	0.005	0.269	0.055
1/2	5/8	0.625	0.049	0.344	0.094
5/8	3/4	0.750	0.049	0.418	0.144
3/4	7/8	0.875	0.065	0.641	0.188
1	1 1/8	1.125	0.065	0.839	0.337
1 1/4	1 3/8	1.375	0.065	1.040	0.527
1 1/2	1 5/8	1.625	0.072	1.360	0.743
2	2 1/8	2.125	0.083	2.060	1.310
2 1/2	2 5/8	2.625	0.095	2.920	2.000
3	3 1/8	3.125	0.109	4.000	2.960
3 1/2	3 5/8	3.625	0.120	5.120	3.900
4	4 1/8	4.125	0.134	6.510	5.060
5	5 1/8	5.125	0.160	9.670	8.000
6	6 1/8	6.125	0.192	13.870	11.200
8	8 1/8	8.125	0.271	25.900	19.500
10	10 1/8	10.125	0.338	40.300	30.423
12	12 1/8	12.125	0.405	57.800	43.675

**SPACING OF HANGERS FOR COPPER TUBING**

<b>Tubing Size</b>	1/2	3/4	1	1 1/4	1 1/2	2	2 1/2	3	3 1/2	4	5	6	8	10	12
<b>Span in Ft.</b>	6	8	8	10	10	10	12	12	12	12	12	14	14	18	19

# TECHNICAL DATA

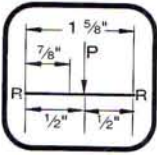

## PVC PLASTIC PIPE DATA – Schedule 40 & 80

Nom. Tube Size	Schedule No.	O.D.	Wall Thick	Wt./Ft. Lbs.	Wt. of Water/Ft. Lbs.
1/8	40	0.405	0.068	0.043	0.025
	80		0.095	0.055	0.016
1/4	40	0.540	0.088	0.074	0.045
	80		0.119	0.094	0.031
3/8	40	0.675	0.091	0.100	0.083
	80		0.126	0.129	0.061
1/2	40	0.840	0.109	0.150	0.132
	80		0.147	0.150	0.101
3/4	40	1.050	0.113	0.199	0.230
	80		0.154	0.259	0.186
1	40	1.315	0.133	0.295	0.374
	80		0.179	0.382	0.311
1 1/4	40	1.660	0.140	0.400	0.647
	80		0.191	0.527	0.555
1 1/2	40	1.990	0.145	0.478	0.882
	80		0.200	0.639	0.765
2	40	2.375	0.154	0.643	1.452
	80		0.218	0.884	1.279

Nom. Tube Size	Schedule No.	O.D.	Wall Thick	Wt./Ft. Lbs.	Wt. of Water/Ft. Lbs.
2 1/2	40	2.875	0.203	1.020	2.072
	80		0.276	1.350	1.834
3	40	3.500	0.216	1.333	3.200
	80		0.300	1.804	2.860
3 1/2	40	4.000	0.226	1.598	4.280
	80		0.318	2.195	3.850
4	40	4.500	0.237	1.899	5.510
	80		0.337	2.636	4.980
5	40	5.563	0.258	2.770	8.660
	80		0.375	4.126	7.870
6	40	6.625	0.280	3.339	12.150
	80		0.432	5.028	11.290
8	40	8.625	0.322	5.280	21.600
	80		0.500	8.023	19.800
10	40	10.750	0.366	7.505	34.100
	80		0.593	11.894	31.100
12	40	12.750	0.406	10.023	48.500
	80		0.687	16.365	44.000

## SPACING OF HANGERS FOR PVC PLASTIC PIPE

Sch. 40 Pipe Size	Support Spacings in Feet at Temperatures Shown Above									
	20°F	40°F	60°F	80°F	100°F	110°F	120°F	130°F	140°F	150°F
1/2" – 3/4"	5.00	4.75	4.50	4.25	4.00	3.75	3.33	3.00	2.66	2.00
1" – 1 1/4"	5.50	5.25	5.00	4.66	4.33	4.00	3.75	3.33	2.80	2.25
1 1/2" – 2"	5.80	5.50	5.25	5.00	4.66	4.33	3.80	3.50	3.00	2.50
2 1/2"	6.66	6.33	6.00	5.50	5.25	4.80	4.50	4.00	3.50	2.80
3"	6.80	6.50	6.25	5.80	5.50	5.25	4.75	4.25	3.66	3.00
4"	7.33	7.00	6.50	6.25	5.80	5.50	5.00	4.50	3.80	3.25
6"	7.80	7.50	7.00	6.80	6.33	5.80	5.33	4.80	4.25	3.50

Sch. 40 Pipe Size	Support Spacings in Feet at Temperatures Shown Above									
	20°F	40°F	60°F	80°F	100°F	110°F	120°F	130°F	140°F	150°F
1/2" – 3/4"	5.75	5.50	5.25	4.80	4.50	4.33	3.80	3.50	3.00	2.50
1"	6.33	6.00	5.75	5.33	5.00	4.60	4.33	3.80	3.33	2.75
1 1/4" – 1 1/2"	6.66	6.33	6.00	5.66	5.25	4.80	4.50	4.00	3.50	3.00
2"	7.00	6.50	6.25	6.00	5.50	5.12	4.75	4.33	3.66	3.12
2 1/2"	7.80	7.50	7.00	6.66	6.33	5.80	5.33	4.75	4.25	3.33
3"	8.20	7.75	7.33	7.00	6.50	6.00	5.50	5.00	4.33	3.50
4"	8.66	8.25	7.80	7.33	6.80	6.33	5.80	5.25	4.66	3.75
6"	9.80	9.33	8.80	8.33	7.80	7.33	6.50	6.00	5.12	4.25

NOTE: Tables assume fluid loads up to 1.35 specific gravity (85 lb./cu. ft.), but not concentrated heavy loads.

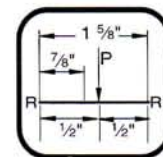

**CAST IRON PIPE DATA**

Nom. Tube Size	Class	O.D.	Wall Thick	Wt./ Ft.	Wt. of Water Ft. Lbs.
3	150	3.96	0.32	12.20	3.73
4	150	4.80	0.35	16.40	5.72
6	150	6.90	0.38	25.70	12.80
8	150	9.05	0.41	36.70	23.10
10	150	11.10	0.44	48.70	35.50
12	150	13.20	0.48	62.90	51.00
14	150	15.30	0.51	78.80	69.30
16	150	17.40	0.54	95.00	90.30
18	150	19.50	0.58	114.70	114.00
20	150	21.60	0.62	135.90	141.50
24	150	25.80	0.73	190.40	201.00
30	150	32.00	0.85	277.30	312.00
36	150	38.30	0.94	368.90	449.00
42	150	44.50	1.05	479.10	612.00
48	150	50.80	1.14	595.20	803.00

Nom. Pipe Size	O.D.	Wall Thick	Wt./Ft. Lbs.	Wt. of Water/Ft. lbs.
1 1/2	1.84	0.12	0.64	0.89
2	2.34	0.14	0.94	1.45
3	3.41	0.17	1.60	3.19
4	4.53	0.20	2.60	5.79
6	6.66	0.24	4.70	12.78
<b>Heavy Schedule</b>				
1	1.31	0.16	0.60	0.35
1 1/2	1.84	0.17	0.87	0.76
2	2.34	0.17	1.10	1.36
3	3.41	0.20	2.00	3.06
4	4.53	0.26	3.40	5.44
6	6.66	0.33	6.30	12.42

Mechanical Joint Pipe Class 150. Approximately same weight for Bell & Spigot. Flange cast iron pipe add weight of flanges.

Spacing of Hangers for glass pipe support every 8-10 ft. Pad all hangers. Use only clevis or trapeze, do not tie down pipe.

**LOAD CARRYING CAPACITIES OF THREADED HOT ROLLED STEEL ROD**

Nominal Rod Dia. Inches	Root Area Sq. Inches	Maximum Safe Load, Pounds	
		650°	750°
1/4	0.027	240	210
3/8	0.068	610	540
1/2	0.126	1130	1010
5/8	0.202	1810	1610
3/4	0.302	2710	2420
7/8	0.419	3770	3030
1	0.552	4960	4420
1 1/8	0.693	6230	5560
1 1/4	0.889	8000	7140
1 1/2	1.293	11630	10370
1 3/4	1.744	15700	14000
2	2.300	20700	18460
2 1/4	3.023	27200	24260
2 1/2	3.719	33500	29880

# TABLE OF CONVERSIONS

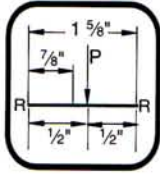

To Convert From	To	Multiply By	To Convert From	To	Multiply By
<b>Length</b>					
Inch [in]	Millimeter [mm]	25.400 000	Millimeter [mm]	Inch [in]	0.039 370
Foot [ft]	Meter [m]	0.304 800	Meter [m]	Foot [ft]	3.280 840
Yard [yd]	Meter [m]	0.914 400	Meter [m]	Yard [yd]	1.093 613
Mile (U.S. Statute) [mi]	Kilometer [km]	1.609 347	Kilometer [km]	Mile (U.S. Statute) [mi]	0.621 370
<b>Area</b>					
Square Inch [in <sup>2</sup> ]	Square Millimeter [mm <sup>2</sup> ]	645.16	Square Millimeter [mm <sup>2</sup> ]	Square Inch [in <sup>2</sup> ]	0.001550
Square Foot [ft <sup>2</sup> ]	Square Meter [m <sup>2</sup> ]	0.092 903	Square Meter [m <sup>2</sup> ]	Square Foot [ft <sup>2</sup> ]	10.763 915
Square Yard [yd <sup>2</sup> ]	Square Meter [m <sup>2</sup> ]	0.836 127	Square Meter [m <sup>2</sup> ]	Square Yard [yd <sup>2</sup> ]	1.195 991
Square Mile [mi <sup>2</sup> ] (U.S. Statute)	Square Kilometer [km <sup>2</sup> ]	2.589 998	Square Kilometer [km <sup>2</sup> ]	Square Mile [mi <sup>2</sup> ] (U.S. Statute)	0.386 101
Acre	Square Meter [m <sup>2</sup> ]	4046.873	Square Meter [m <sup>2</sup> ]	Acre	0.000 247
Acre	Hectare	0.404 687	Hectare	Acre	2.471 046
<b>Volume</b>					
Cubic Inch [in <sup>3</sup> ]	Cubic Millimeter [mm <sup>3</sup> ]	16387.06	Cubic Millimeter [mm <sup>3</sup> ]	Cubic Inch [in <sup>3</sup> ]	0.000061
Cubic Foot [ft <sup>3</sup> ]	Cubic Meter [m <sup>3</sup> ]	0.028 317	Cubic Meter [m <sup>3</sup> ]	Cubic Foot [ft <sup>3</sup> ]	35.314 662
Cubic Yard [yd <sup>3</sup> ]	Cubic Meter [m <sup>3</sup> ]	0.764 555	Cubic Meter [m <sup>3</sup> ]	Cubic Yard [yd <sup>3</sup> ]	1.307 950
Gallon (U.S. Liquid) [gal]	Litre [l]	3.785 412	Litre [l]	Gallon (U.S. Liquid) [gal]	0.264 172
Quart (U.S. Liquid) [qt]	Litre [l]	0.946 353	Litre [l]	Quart (U.S. Liquid) [qt]	1.056 688
<b>Mass</b>					
Ounce (Avoirdupois) [oz]	Gram [g]	28.349 520	Gram [g]	Ounce (Avoirdupois) [oz]	0.035 274
Pound (Avoirdupois) [lb]	Kilogram [kg]	0.453 592	Kilogram [kg]	Pound (Avoirdupois) [lb]	2.204 624
Short Ton	Kilogram [kg]	907.185	Kilogram [kg]	Short Ton	0.00110
<b>Force</b>					
Ounce-Force	Newton [N]	0.278 014	Newton [N]	Ounce-Force	3.596 941
Pound-Force [lbf]	Newton [N]	4.448 222	Newton [N]	Pound-Force [lbf]	0.224 809
<b>Bending Moment</b>					
Pound-Force-Inch [lbf-in]	Newton-Meter [N-m]	0.112 985	Newton-Meter [N-m]	Pound-Force-Inch [lbf-in]	8.850 732
Pound-Force-Foot [lbf-ft]	Newton-Meter [N-m]	1.355 818	Newton-Meter [N-m]	Pound-Force-Foot [lbf-ft]	0.737 562
<b>Pressure, Stress</b>					
Pound-Force per Square Inch [lbf/in <sup>2</sup> ]	Kilopascal [kPa]	6.894 757	Kilopascal [kPa]	Pound-Force per Square Inch [lbf/in <sup>2</sup> ]	0.145 038
Foot of Water (39.2 F)	Kilopascal [kPa]	2.988 980	Kilopascal [kPa]	Foot of Water (39.2 F)	0.334 562
Inch of Mercury (32 F)	Kilopascal [kPa]	3.386 380	Kilopascal [kPa]	Inch of Mercury (32 F)	0.295 301
<b>Energy, Work, Heat</b>					
Foot-Pound-Force [ft-lbf]	Joule [J]	1.355 818	Joule [J]	Foot-Pound-Force [ft-lbf]	0.737 562
British Thermal Unit [Btu]	Joule [J]	1055.056	Joule [J]	British Thermal Unit [Btu]	0.000948
Calorie [cal]	Joule [J]	4.186 800	Joule [J]	Calorie [cal]	0.238 846
Kilowatt Hour [kW-h]	Joule [J]	3600000	Joule [J]	Kilowatt Hour [kW-h]	2.78 <sup>-7</sup>
<b>Power</b>					
Foot-Pound-Force /Second [ft-lbs/s]	Watt [W]	1.355 818	Watt [W]	Foot-Pound-Force /Second [ft-lbs/s]	0.737 562
British Thermal Unit /Hour [Btu/h]	Watt [W]	0.293 071	Watt [W]	British Thermal Unit /Hour [Btu/h]	3.412 142
Horsepower (550 Ft. Lbf/s) [hp]	Kilowatt [kW]	0.745 700	Kilowatt [kW]	Horsepower (550 Ft. Lbf/s) [hp]	1.341 022
<b>Angle</b>					
Degree	Radian [rad]	0.017 453	Radian [rad]	Degree	57.295 788
<b>Temperature</b>					
Degree Fahrenheit [F]	Degree Celsius [C]	(F° - 32)/1.8	Degree Celsius [C]	Degree Fahrenheit [F]	1.8xC° + 32

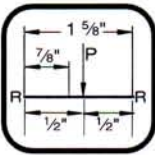

	1/64	0.015625		33/64	0.515625
	1/32	0.03125		17/32	0.53125
	3/64	0.046875		35/64	0.546875
1/16		0.0625	9/16		0.5625
	5/64	0.078125		37/64	0.578125
	3/32	0.09375		19/32	0.59375
	7/64	0.109375		39/64	0.609375
1/8		0.125	5/8		0.625
	9/64	0.140625		41/64	0.640625
	5/32	0.15625		21/32	0.65625
	11/64	0.171875		43/64	0.671875
3/16		0.1875	11/16		0.6875
	13/64	0.203125		45/64	0.703125
	7/32	0.21875		23/32	0.71875
	15/64	0.234375		47/64	0.734375
1/4		0.25	3/4		0.75
	17/64	0.265625		49/64	0.765625
	9/32	0.28125		25/32	0.78125
	19/64	0.296875		51/64	0.796875
5/16		0.3125	13/16		0.8125
	21/64	0.328125		53/64	0.828125
	11/32	0.34375		27/32	0.84375
	23/64	0.359375		55/64	0.859375
3/8		0.375	7/8		0.875
	25/64	0.390625		57/64	0.890625
	13/32	0.40625		29/32	0.90625
	27/64	0.421875		59/64	0.921875
7/16		0.4375	15/16		0.9375
	29/64	0.453125		61/64	0.953125
	15/32	0.46875		31/32	0.96875
	31/64	0.484375		63/64	0.984375
1/2		0.5	1		1.



# GENERAL APPLICATIONS

## SUPPORTS



### STANDARD CHANNEL AND FITTING ASSEMBLY

The factory punched holes in "H" series channel allow fittings to be attached to either side.

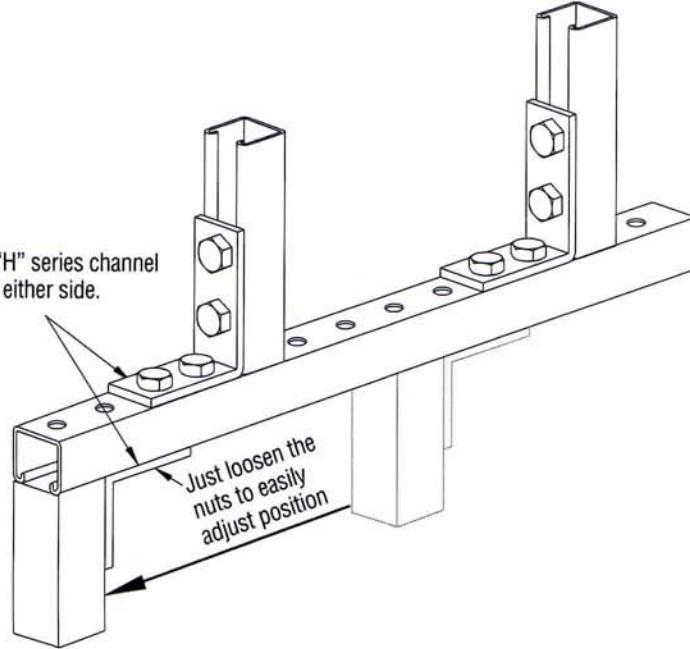

### FLOOR MOUNTED STAND

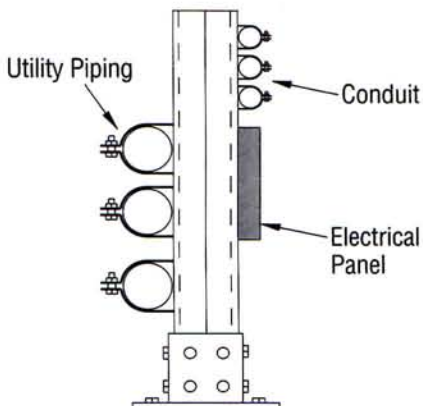

Island stands allow you to mount equipment or piping on both sides in trenches and in service isles.

### ELECTRICAL PANEL SUPPORTS

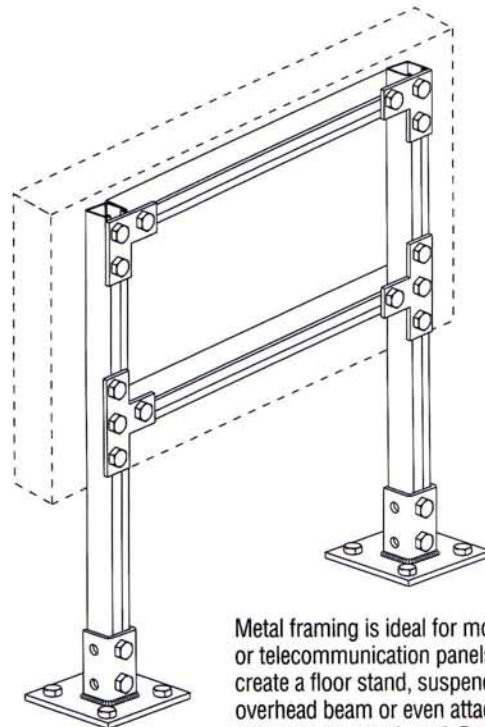

Metal framing is ideal for mounting electrical or telecommunication panels. It allows you to create a floor stand, suspend panels from an overhead beam or even attach panels to adjacent structural steel. Bracing may be added for heavier load requirements.



# GENERAL APPLICATIONS

## OVERHEAD SUPPORTS



### TRAPEZE SUPPORT SYSTEM

Power-Strut metal framing is ideal for electrical and mechanical pipe support applications.

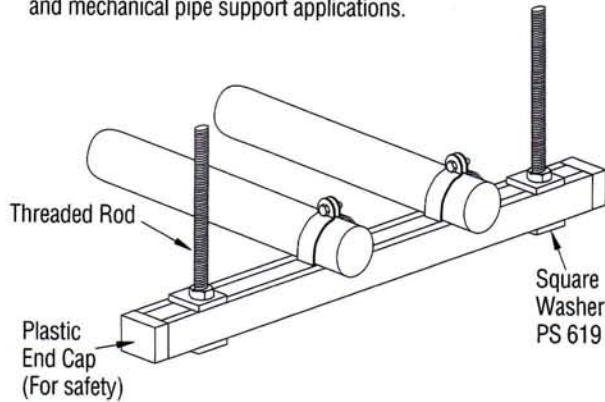

Acceptable Methods to Hang Channels

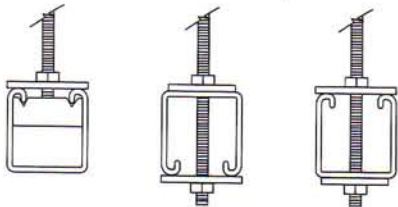

Pre-slotted channel allow through channel connections

### SUPPORTS FOR THREADED ROD ATTACHMENTS BETWEEN BEAMS

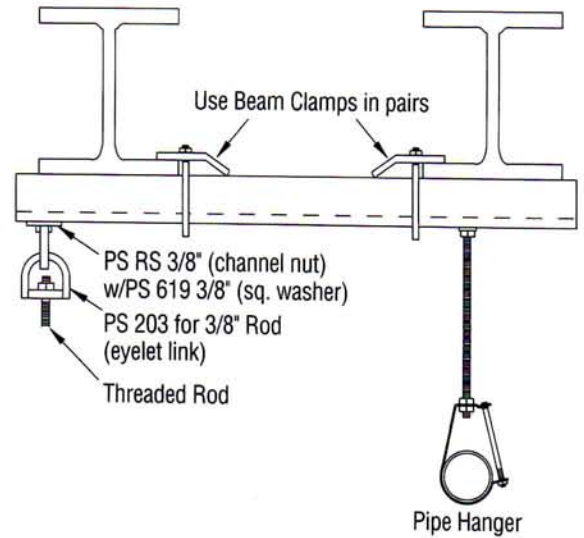

Select channel size based on load requirements

### GANGED PIPE SUPPORT

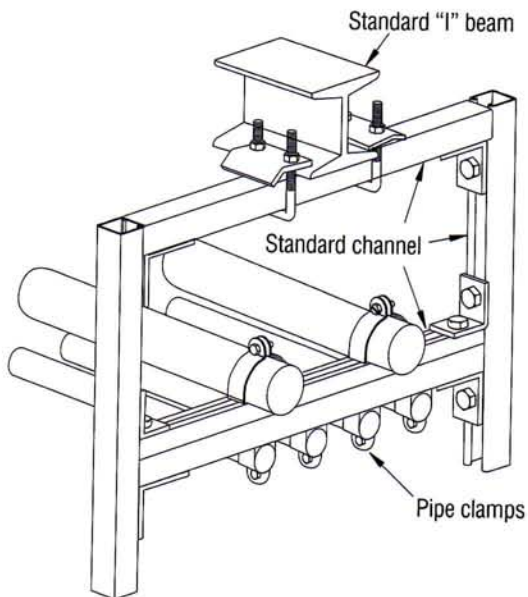

### SUPPORTS FOR THREADED ROD ATTACHMENTS TO SINGLE BEAMS

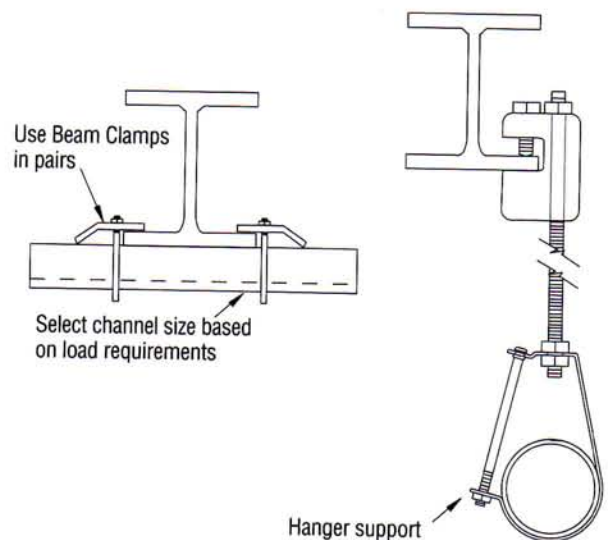



# GENERAL APPLICATIONS

## OVERHEAD & WALL SUPPORTS



### OVERHEAD SUPPORT VERTICAL TO HORIZONTAL

Anchor  
(suitable for wall material)

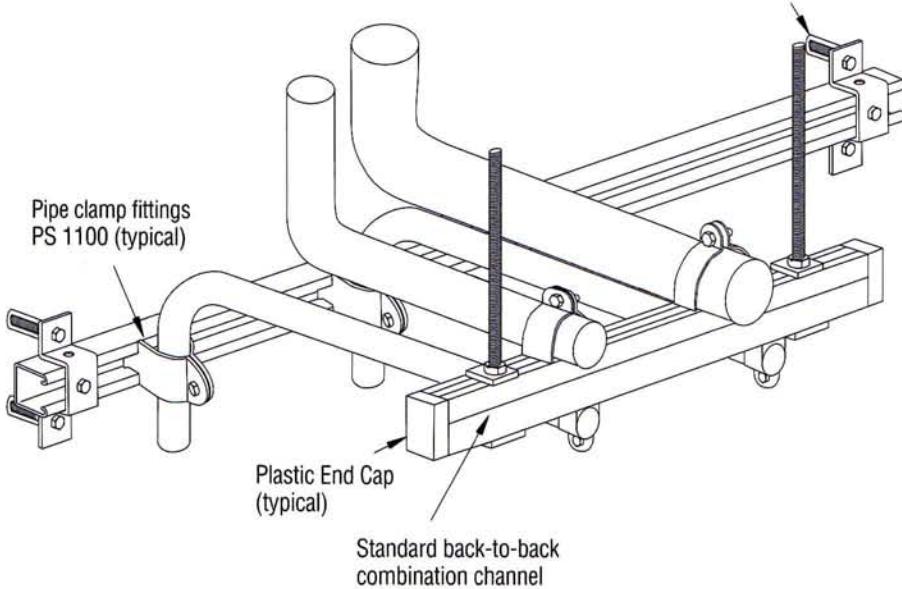

Pipe clamp fittings  
PS 1100 (typical)

Plastic End Cap  
(typical)

Standard back-to-back  
combination channel

Square Washer  
PS 619 w/Hex Nut

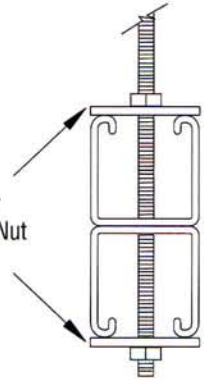

### WALL MOUNT ORGANIZE & CONTROL

Anchor  
(suitable for wall material)

PS 611  
(typical)

Pipe clamp  
fittings  
(typical)

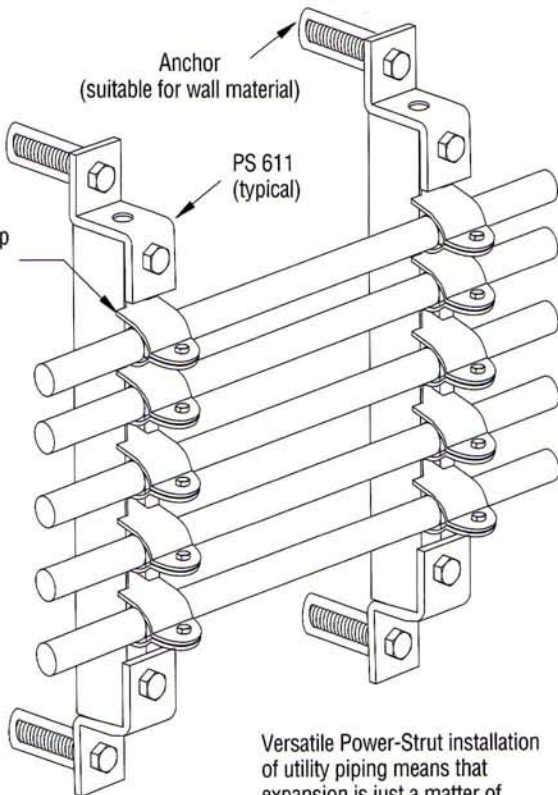

Versatile Power-Strut installation  
of utility piping means that  
expansion is just a matter of  
inserting another pipe clamp!

### OVERHEAD MULTI-USE SUPPORT SYSTEMS USING CHANNEL ATTACHED TO "I" BEAMS

Check span for allowable load

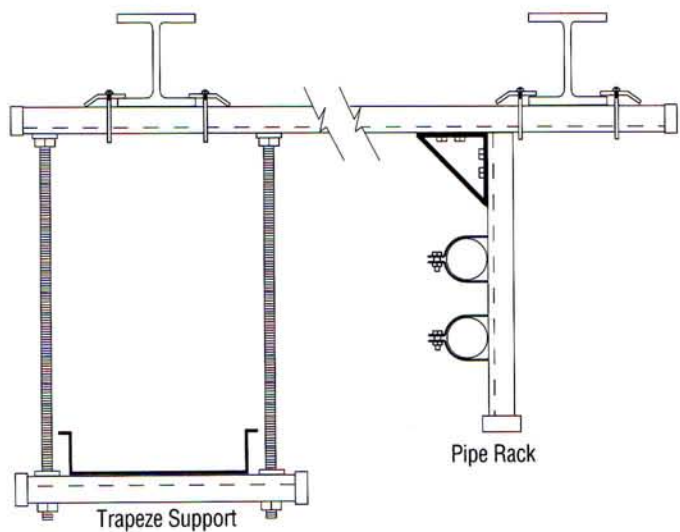

Trapeze Support

Pipe Rack





# GENERAL APPLICATIONS

## WALL SUPPORTS



### MULTI-SHELF OR UTILITY SUPPORT

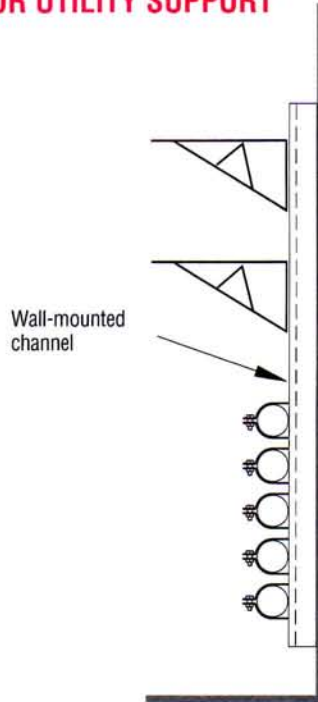

### WALL MOUNTED BRACKETS

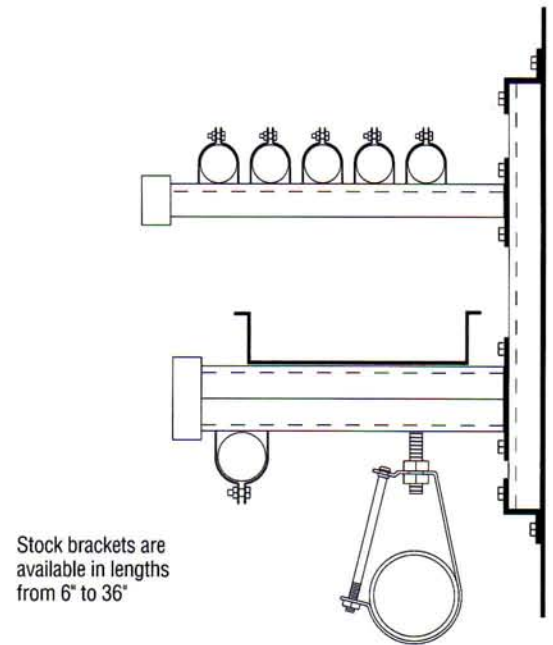

### WALL-MOUNTED SINGLE LINES

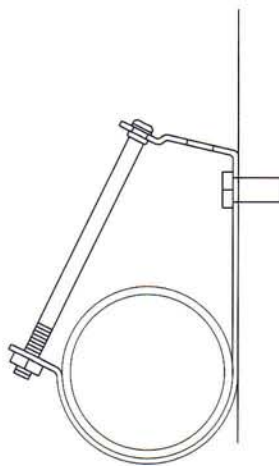

### CUSHIONED CLAMPS

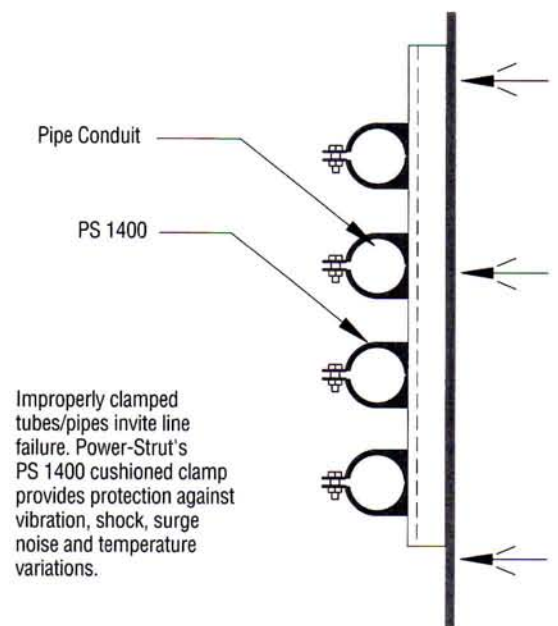



# PRODUCT INDEX



PS 51 .....	113	PS 270 .....	113	PS 626 .....	82	PS 716 R or L .....	56
PS 52E .....	113	PS 285 .....	118	PS 629 .....	67	PS 718 .....	50
PS 67 .....	112	PS 300 2T3 .....	27	PS 631 .....	66	PS 719 .....	50
PS 69 .....	112	PS 300 EH .....	25	PS 633 .....	58	PS 720 R or L .....	56
PS 70 .....	112	PS 300 H .....	25	PS 644 .....	66	PS 721 .....	64
PS 83 .....	44	PS 300 KO6 .....	25	PS 645 .....	66	PS 723 .....	110
PS 85 .....	95	PS 300 S .....	25	PS 646 .....	66	PS 732 .....	83
PS 86 .....	95	PS 300 .....	25	PS 647 .....	62	PS 733 .....	64
PS 93 .....	96	PS 349 .....	115	PS 649 .....	107	PS 734 .....	65
PS 94 .....	96	PS 400 2T3 .....	30	PS 651 .....	82	PS 735 .....	65
PS 95 .....	95	PS 400 EH .....	28	PS 653 .....	117	PS 736 .....	92
PS 100 2T3 .....	10	PS 400 H .....	28	PS 654 .....	117	PS 744 .....	51
PS 100 EH .....	8	PS 400 KO6 .....	28	PS 655 .....	102	PS 745 .....	54
PS 100 H .....	8	PS 400 S .....	28	PS 656 .....	102, 117	PS 746 .....	57
PS 100 KO6 .....	8	PS 400 .....	28	PS 658 .....	103	PS 747 .....	52
PS 100 S .....	8	ps 449 .....	116	PS 659 .....	103	PS 748 .....	57
PS 100 .....	8	PS 500 2T3 .....	33	PS 660 .....	55	PS 750 .....	51
PS 135X .....	95	PS 500 EH .....	31	PS 661 .....	82	PS 752 R or L .....	57
PS 135 .....	43	PS 500 H .....	31	PS 665 .....	69	PS 756 .....	61
PS 146 .....	43	PS 500 S .....	31	PS 666 .....	69	PS 760 .....	108
PS 150 2T3 .....	13	PS 500 .....	31	PS 667 .....	69	PS 763 .....	53
PS 150 EH .....	11	PS 517 .....	46	PS 668 .....	71	PS 764 .....	53
PS 150 H .....	11	PS 520 2T3 .....	36	PS 669 .....	71	PS 781 .....	58
PS 150 KO6 .....	11	PS 520 EH .....	34	PS 670 .....	71	PS 791 .....	109
PS 150 S .....	11	PS 520 H .....	34	PS 671 .....	108	PS 793 .....	58
PS 150 .....	11	PS 520 S .....	34	PS 677 .....	64	PS 803 .....	103
PS 152 .....	118	PS 520 .....	34	PS 678 .....	64	PS 804 .....	66
PS 200 2T2 .....	17	PS 560 2T3 .....	39	PS 679 .....	63	PS 805 .....	107
PS 200 2T3 .....	16	PS 560 EH .....	37	PS 680 .....	118	PS 806 .....	54
PS 200 2T4 .....	17	PS 560 H .....	37	PS 684 .....	92	PS 807 .....	104
PS 200 2T5 .....	17	PS 560 S .....	37	PS 685 .....	91	PS 808 .....	82
PS 200 3T6 .....	17	PS 560 .....	37	PS 686 .....	91	PS 809 .....	83
PS 200 EH .....	14	PS 600J .....	124	PS 687A .....	63	PS 810 .....	60
PS 200 H .....	14	PS 601 .....	49	PS 687B .....	63	PS 812 .....	60
PS 200 H3 .....	14	PS 602 .....	49	PS 687C .....	63	PS 815 .....	87
PS 200 KO6 .....	14	PS 603 .....	53	PS 689A .....	56	PS 816 .....	88
PS 200 PLA .....	20	PS 604 .....	53	PS 689B .....	56	PS 821 .....	70
PS 200 PLB .....	20	PS 605 .....	54	PS 692 .....	62	PS 822 .....	52
PS 200 PLC .....	20	PS 606 .....	54	PS 693 .....	107	PS 825 R or L .....	84
PS 200 S .....	14	PS 607 .....	55	PS 694 .....	107	PS 826 .....	84
PS 200 SB .....	14	PS 609 .....	62	PS 700J .....	125	PS 838 R or L .....	84
PS 200 .....	14	PS 611 .....	61	PS 702 D .....	106	PS 854 .....	52
PS 202 .....	47	PS 612 .....	61	PS 702 .....	105	PS 855 .....	90
PS 203 .....	47	PS 613 .....	63	PS 703 D .....	106	PS 858L .....	94
PS 204 .....	47	PS 614 .....	55	PS 703 .....	105	PS 858 .....	94
PS 205 .....	47	PS 615 .....	55	PS 704 .....	67	PS 865 .....	94
PS 209 .....	44	PS 616 .....	66	PS 707 .....	106	PS 871 .....	93
PS 210 2T3 .....	24	PS 617 .....	49	PS 708 .....	83	PS 888 .....	50
PS 210 EH .....	22	PS 618 .....	49	PS 709 .....	65	PS 889 .....	50
PS 210 H .....	22	PS 619 .....	49	PS 710 .....	63	PS 901 .....	102, 117
PS 210 KO6 .....	22	PS 620 .....	50	PS 711 .....	61	PS 902 .....	102
PS 210 S .....	22	PS 621 .....	50	PS 712 .....	51	PS 907 .....	91
PS 210 .....	22	PS 622 .....	57	PS 713 .....	56	PS 913 .....	70
PS 211 .....	44	PS 624 .....	58	PS 714 .....	51	PS 916 .....	92
PS 230 .....	44			PS 715 .....	56	PS 921 .....	53



# PRODUCT INDEX



PS 922 R or L .....	68	PS 2112 .....	52	PS 2661 .....	107	PS 3457 .....	122
PS 923 .....	70	PS 2113 .....	58	PS 2662 - A .....	107	PS 3458 .....	122
PS 925 .....	51	PS 2117 R or L .....	68	PS 2800 .....	109	PS 3459 .....	122
PS 926 .....	60	PS 2119 .....	63	PS 2801 .....	109	PS 3500 .....	43
PS 927 .....	56	PS 2128 R or L .....	68	PS 2802 .....	109	PS 3792 .....	40, 79
PS 928 .....	61	PS 2129 R or L .....	68	PS 2803 .....	109	PS 4017 .....	126
PS 929 .....	64	PS 2144 .....	53	PS 3013 SQ .....	72	PS 5000 2T3 .....	121
PS 930 .....	102	PS 2190 .....	51	PS 3013 .....	72	PS 5000 .....	120
PS 942 .....	107	PS 2401 thru PS 2403 .....	85	PS 3017 .....	126	PS 6024 .....	42
PS 943 .....	69	PS 2404 thru PS 2408 .....	85	PS 3025 FL .....	72	PS 6064 .....	43
PS 945 .....	70	PS 2421 .....	85	PS 3025 .....	72	PS 6072 .....	42
PS 978 .....	64	PS 2422 .....	85	PS 3029 .....	73	PS 6075 .....	42
PS 993 .....	65	PS 2504 .....	49	PS 3033 SQ .....	72	PS 6108 .....	42
PS 998 .....	91	PS 2511 .....	102	PS 3033 .....	72	PS 6151 .....	117
PS 1000 .....	77	PS 2514 .....	71	PS 3040 .....	72	PS 6152 .....	40
PS 1004 .....	67	PS 2520 .....	54	PS 3041 .....	73	PS 6153 .....	40
PS 1100 .....	77	PS 2521 .....	74	PS 3049 .....	55	PS 9050 .....	40
PS 1116 .....	77	PS 2522 .....	74	PS 3060 .....	62	PS 9227 .....	122
PS 1117 .....	77	PS 2523 .....	62	PS 3064 .....	73	PS 9400 .....	58
PS 1154 .....	117	PS 2524 .....	75	PS 3101 thru PS 3115 .....	80	PS 9401 .....	59
PS 1200 .....	78	PS 2525 .....	75	PS 3126 .....	79	PS 9402 .....	59
PS 1300 .....	77	PS 2528 - 1 .....	74	PS 3138 .....	79	PS 9403 .....	59
PS 1400 .....	80	PS 2528 .....	74	PS 3164 .....	83	PS 9404 .....	59
PS 1450 .....	79	PS 2532 .....	62	PS 3201 .....	93	PS LS .....	45
PS 1500 .....	110	PS 2545 .....	54	PS 3281 .....	45	PS NS S .....	46
PS 1510 .....	110	PS 2560 .....	102	PS 3282 .....	84	PS NS .....	46
PS 1610 .....	111	PS 2561 .....	102	PS 3301 .....	104	PS RS .....	45
PS 1801 .....	111	PS 2580 .....	102	PS 3326 R or L .....	57	PS SS .....	46
PS 1850 .....	111	PS 2581 .....	102	PS 3373 .....	55	PS TG .....	45
PS 1901 .....	87	PS 2582 .....	107	PS 3420 .....	122	PS TGS .....	45
PS 1902 .....	87	PS 2585 .....	102				
PS 1911 .....	88	PS 2601 .....	61				
PS 2007 R or L .....	57	PS 2621 .....	102				
PS 2008 .....	127	PS 2622 .....	92				
PS 2010 .....	128	PS 2623 .....	93				
PS 2011 .....	129	PS 2624 .....	93				
PS 2013 .....	126	PS 2625 .....	103				
PS 2014 .....	126	PS 2626 .....	94				
PS 2015 .....	126	PS 2627 .....	109				
PS 2016 .....	126	PS 2631D .....	104				
PS 2017 .....	127	PS 2631 .....	104				
PS 2018 .....	127	PS 2632D .....	103				
PS 2019 .....	128	PS 2632 .....	103				
PS 2023 R or L .....	128	PS 2636 .....	105				
PS 2024 .....	128	PS 2637 .....	105				
PS 2025 .....	127	PS 2639 .....	108				
PS 2026 .....	128	PS 2640 .....	102				
PS 2029 .....	129	PS 2648 .....	63				
PS 2033 .....	127	PS 2651 .....	90				
PS 2034 .....	127	PS 2653 .....	91				
PS 2037 .....	128	PS 2654A .....	94				
PS 2041 .....	129	PS 2654 .....	94				
PS 2054 .....	60	PS 2656 .....	90				
PS 2064 .....	73	PS 2657 .....	90				
PS 2094 .....	108	PS 2660 .....	107				

## TECHNICAL DATA

Design Load - Channel Connections .....	131
Beam Diagrams and Formulas .....	132
Beam Load Conversion Factors .....	134
Section Modulus Required for Trapeze Members .....	135
American Standard Beam Tables .....	136-137
Tables of Pipe Spacing .....	138-139
Conduit Spacings .....	140
Electrical Metallic Tubing Data .....	140
Intermediate Metal Conduit Data .....	141
Steel Rigid Conduit Data .....	141
Steel Pipe Data - Schedule 40 & 80 .....	142
Copper Tube Data .....	143
Spacing of Hangers for Copper Tubing .....	143
Spacing of Hangers for Steel Pipe .....	143
PVC Plastic Pipe Data - Schedule 40 & 80 .....	144
Spacing of Hangers for PVC Plastic Pipe .....	144
Cast Iron Pipe Data .....	145
Load Capacities of Threaded Rod .....	145
Table of Conversions .....	146
Fractions and Decimal Equivalents .....	147

Distributed by:



16100 South Lathrop Avenue  
Harvey, Illinois 60426  
(708) 339-1610



**Grinnell**<sup>®</sup>