

*The Remarkable System
for Building Structures with Pipe
... Quickly ... and at Low Cost!*

HOLLAENDER

**"Instant
Structure"TM**

**STRUCTURAL
ALUMINUM-
MAGNESIUM
SLIP-ON
FITTINGS**



SPEED-RAIL[®]



NU-RAIL[®] &



RACKMASTER[®]

Catalog Issued January, 1973

Supersedes All Previous Issues

Copyright 1973 The Hollaender Mfg. Co.

The easy,
cost & time-saving,
best-looking way
to build with pipe

HOLLAENDER "Instant Structure"™

...with SPEED-RAIL,® NU-RAIL® & RACKMASTER®
Structural Slip-On Fittings

SPEED-RAIL An *inline* fitting for conventional railings and other structures. Not recommended for heavy-duty rack construction.

NU-RAIL *Offset* design permits pipe to cross pipe without cutting. Reduces pipe cutting to a minimum. For heavy-duty railing and racks.

RACKMASTER A specialized development of the Nu-Rail line, with same *offset design*. Special fittings for racks and other heavier construction.

Many applications may combine selections from the three types.

The many millions of these fittings in use tell the story of Hollaender quality and dependability

ALL SPEED-RAIL, NU-RAIL AND RACKMASTER FITTINGS HAVE THESE BASIC CHARACTERISTICS

- Slip-on installation with self-locking setscrews. Reduced pipe cutting. Simple, easy erection. Overall labor saving up to 30%.
- No threading, welding, nuts, bolts or washers.
- Same special aluminum-magnesium alloy.
- Same cadmium-plated steel alloy setscrews.
- Raised setscrew boss *full length* of barrels.
- 100% salvageability, if desired for future uses.

THE ALLOY

A high-tensile alloy of aluminum and magnesium with these physical properties:

	MINIMUM	TYPICAL
Tensile Strength	34,000 Lbs.	36-38,000 Lbs.
Yield Strength	17,000 Lbs.	18-19,000 Lbs.
Elongation	7%	9-10%

Strength compares favorably with the strength of malleable iron, at one-third the weight. Develops full strength immediately upon casting and its properties remain for the life of the casting.

CHEMICAL COMPOSITION (%)

Magnesium	6.6 to 7.5	Zinc	None	
Iron12 Max.	Chromium	None
Manganese	.05	Nickel	None	
Titanium	..	.10 to .25	Tin	None
Silicon10 Max.	Others15 Max.*
Copper05 Max.	Aluminum	..	Remainder

(* .05 Max. any one)

The above chemical composition fully meets Military and Federal Specifications QQ-A-601E and QQ-A-371F. As of March 5, 1976, there is no ASTM Specification for this Alloy. The Aluminum Association has designated this Alloy as B-535.2.

Corrosion resistance is very high since many of those elements which induce electrolytic action are either absent or in extremely low percentage. In most applications, pipe of any structurally-suitable material may be used.

REGARDING OSHA REGULATIONS — Note that more than 100 Hollaender "Instant Structure" Fittings are sized to comply with the Safety Railings Regulations of the 1970 Dept. of Labor Occupational Safety and Health Act. Plus, these Fittings have extra built-in strength in both alloy and design. And the well-known labor cost-saving in building anything with "Instant Structure" Fittings makes compliance with the Act a SAVING . . . not a premium!

However, if desired, our fittings can be anodized for additional corrosion resistance and more pleasing decorative appearance. In extremely corrosive atmospheres, both fittings and I.P.S. sized aluminum pipe should be anodized and stainless steel set screws used, which we furnish at slight additional cost. If pre-coated steel pipe is used, our fittings are available coated to match the available pipe. Anodized and pre-coated fitting prices are available on request.

THE SETSCREW

Hollaender Speed-Rail, Nu-Rail and Rackmaster Fittings are furnished with cup-pointed setscrews manufactured from highest quality domestic alloy steel. They conform, in all areas, to specifications and standards FF-S-200 (U.S. Gov't.) and USAS B 18.3 Fastener Industry Standard.

The setscrew point bites into the pipe, preventing the screw from backing out under vibration and increasing the load the screw will carry.

STANDARD IRON PIPE SIZES (I.P.S.)

Hollaender Speed-Rail, Nu-Rail and Rackmaster Fittings are gauged to Standard I.P.S. Pipe Dimensions for steel and aluminum pipe. The I.D. of all Hollaender Fittings has just sufficient clearance over the O.D. of Standard I.P.S. pipe for easy slip-on assembly.

In most cases, these fittings work equally well with tubing of O.D. comparable to that of I.P.S. pipe.

Thin-wall tubing, of any material, is not recommended for any structural work.

Each Hollaender Speed-Rail, Nu-Rail and Rackmaster Fitting is 100% checked on chrome-clad "Go-No Go" gauges for proper fit over I.P.S. pipe sizes. See I.P.S. pipe size chart on page 13.

We can supply special fittings, and standard fittings in special I.P.S. or tubing sizes, when requested on quantity orders. Check us for availability and quotations on such fittings if your requirements are not served by fittings listed in this catalog.

SPECIFICATION FOR "INSTANT STRUCTURE" FITTINGS

() shall be constructed with high-tensile Aluminum-Magnesium Alloy Speed-Rail, Nu-Rail or Rackmaster Slip-On Pipe Fittings, to be securely fastened to pipe with Cup-Point Setscrews in each barrel of the Fittings, as manufactured by The Hollaender Mfg. Company.

Pipe shall be standard I.P.S. (black steel . . . galvanized steel . . . aluminum . . . or other material specified) Pipe, having the specified outside diameter or of outside diameter to give desired clearance within Fittings.

BUILDING WITH "INSTANT STRUCTURE"™

It's so easy! Here's all you do:

1. Select proper fittings for the job.
2. Cut pipe or I.P.S. sized tubing to length.
3. Slip on fittings, tighten setscrews with the hex wrench that's furnished with the fittings.

The fittings hold tight and look good!

*The only tool you need
is this little hex wrench . . .*

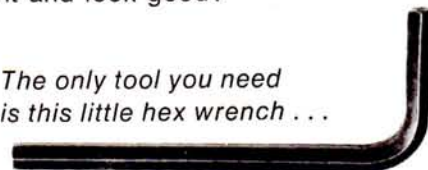

PERMANENT OR TEMPORARY

Everything you build with Speed-Rail, Nu-Rail or Rackmaster Fittings stays there as long as you want it there.

However, should you wish to change or relocate the structure, it can be dismantled as quickly and easily as it was built. All fittings and pipe will be re-usable, 100% salvageable for any desired future uses.

WHAT CAN'T YOU BUILD?

You can build railings and racks, of course. And who knows what else? There's hardly a limit to what people have already built with these fittings . . . or to the size.

























All it takes is imaginative engineering . . . and imaginative engineering keeps pushing out the horizons for "Instant Structure"!

Hollaender **SPEED-RAIL**[®]

In-Line Structural Slip-On Fittings

In Std. I.P.S. Pipe Sizes: 3/4", 1", 1 1/4", 1 1/2"

"Instant Structure"TM

				 No. 3 ELL	 No. 5 TEE
NEW  No. 5-AT 55° ANGLE TEE	 No. 7 CROSS	 No. 9 SIDE-OUTLET ELL	 No. 11 SIDE-OUTLET TEE	 No. 13 SIDE-OUTLET CROSS	
 No. 17 ADJ. ELL or TEE	 No. 19 ADJ. CROSS	NEW  No. 21 - 35° ADJ. CROSS (10° to 35°)	NEW  No. 21 - 45° ADJ. CROSS (30° to 45°)	 No. 23 ADJ. TEE or CROSS	
 No. 25 ADJ. SIDE-OUTLET ELL or TEE	 No. 27 DBL. ADJ. SIDE-OUTLET ELL or TEE	 No. 41 ADJ. FLANGE	 No. 43 FLANGE	NEW  No. 46 FLANGE	
 No. 47 FLANGE	NEW  No. 47-AF 55° ANGLE FLANGE	NEW  No. 48 FLANGE	NEW  No. 49 TOE-BOARD FLANGE	NEW  No. 49-A TOE-BOARD BRACKET	
NEW  No. 49-B TOE-BOARD BRACKET	 No. 60 PLUG	 No. 62 PLUG	NEW  No. 82 HANDRAIL BRACKET	NEW  No. 84 HANDRAIL RETURN BRACKET	



See Pg. 12 for Toe-Board & Handrail applications.

See Pg. 9 or Pg. 11 for Plug data.

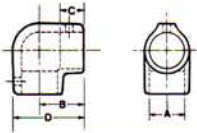
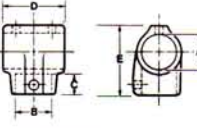
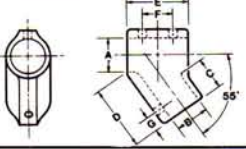
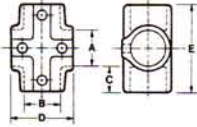
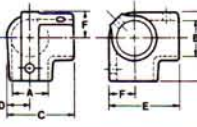
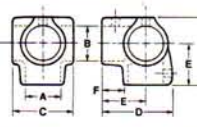
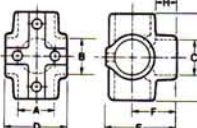
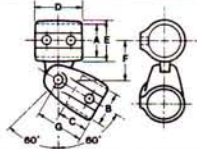
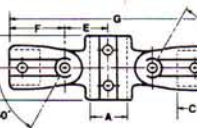
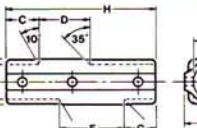
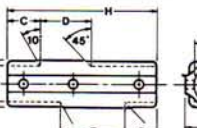
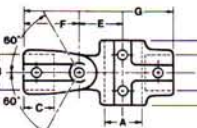
See Pg. 13 for flange bolt hole diameters.

SPEED-RAIL DATA		I.P.S. SIZE	A	B	C	D	E	F	G	H
No. 3 ELL		3/4"	1.070	1-1/2	1	2-13/32				
		1"	1.335	1-25/32	1-1/8	2-7/8				
		1-1/4"	1.680	2	1-3/16	3-3/16				
		1-1/2"	1.925	2-5/16	1-3/8	3-13/16				
No. 5 TEE		3/4"	1.070	1.070	7/8	2	2-11/32			
		1"	1.335	1.335	1	2-3/8	2-3/4			
		1-1/4"	1.680	1.680	1-1/16	2-3/4	3-7/32			
		1-1/2"	1.925	1.925	1-5/16	3-3/8	3-23/32			
No. 5 - AT 55° ANGLE TEE		3/4"	1.070	1.070	1	2	2	1	7/16	
		1"	1.335	1.335	1-1/8	2-7/16	2-3/8	1-1/4	9/16	
		1-1/4"	1.680	1.680	1-1/8	2-3/4	2-3/4	1-1/2	9/16	
No. 7 CROSS		3/4"	1.070	1.070	15/16	2	3			
		1"	1.335	1.335	1-1/8	2-3/8	3-9/16			
		1-1/4"	1.680	1.680	1-1/8	2-3/4	4			
		1-1/2"	1.925	1.925	1-5/16	3-3/8	4-5/8			
No. 9 SIDE-OUTLET ELL		3/4"	1.070	1.070	2-7/32	23/32	2-7/16	1		
		1"	1.335	1.335	2-11/16	29/32	2-7/8	1-1/8		
		1-1/4"	1.680	1.680	3	1-1/16	3-3/16	1-7/32		
		1-1/2"	1.925	1.925	3-7/16	1-3/16	3-23/32	1-5/8		
No. 11 SIDE-OUTLET TEE		3/4"	1.070	1.070	2	2-5/16	1-1/2	15/16	2-3/8	
		1"	1.335	1.335	2-3/8	2-27/32	1-25/32	1	2-27/32	
		1-1/4"	1.680	1.680	2-3/4	3-1/4	2	1-1/16	3-1/4	
		1-1/2"	1.925	1.925	3-1/8	3-23/32	2-5/16	1-1/4	3-23/32	
No. 13 SIDE-OUTLET CROSS		3/4"	1.070	1.070	1.070	2	2-13/32	1-1/2	3	15/16
		1"	1.335	1.335	1.335	2-3/8	2-29/32	1-25/32	3-9/16	1
		1-1/4"	1.680	1.680	1.680	2-3/4	3-9/32	2	4	1-1/16
		1-1/2"	1.925	1.925	1.925	3-1/4	3-23/32	2-5/16	4-5/8	1-1/4
No. 17 ADJ. ELL or TEE		3/4"	1.070	1.070	15/16	1-3/4	1-3/8	1-1/4	1-13/16	
		1"	1.335	1.335	1-1/16	2	1-3/4	1-5/8	1-7/8	
		1-1/4"	1.680	1.680	1-7/16	2-3/8	2-1/8	2-1/16	2-3/16	
		1-1/2"	1.925	1.925	1-3/4	2-3/4	2-5/16	2-3/16	2-5/8	
No. 19 ADJUST. CROSS		3/4"	1.070	1.070	15/16	2	1-5/16	1-15/16	6-1/2	
		1"	1.335	1.335	1-1/16	2-3/8	1-5/8	2	7-1/4	
		1-1/4"	1.680	1.680	1-7/16	2-3/4	1-15/16	2-9/16	9	
		1-1/2"	1.925	1.925	1-3/4	3-3/8	2-1/4	2-3/4	10	
No. 21 - 35° ADJ. CROSS (10° to 35°)		3/4"	1.070	1.070	7/8	1-5/16	1-15/16	1-13/32	1-11/16	4
		1"	1.335	1.335	1	1-21/32	2-3/8	1-3/4	2-3/32	4-13/16
		1-1/4"	1.680	1.680	1-1/16	2-1/16	2-15/16	2-1/8	2-7/16	5-1/2
		1-1/2"	1.925	1.925	1-11/32	2-3/8	3-7/16	2-3/8	2-13/16	6-3/8
No. 21 - 45° ADJ. CROSS (30° to 45°)		3/4"	1.070	1.070	7/8	1-1/2	1-15/16	1-13/32	1-11/16	4-1/2
		1"	1.335	1.335	1	1-29/32	2-5/16	1-3/4	2-3/32	5-1/2
		1-1/4"	1.680	1.680	1-1/16	2-3/8	3	2-1/8	2-7/16	6-3/8
		1-1/2"	1.925	1.925	1-3/16	2-11/16	3-9/16	2-3/8	2-13/16	7-1/4
No. 23 ADJ. TEE or CROSS		3/4"	1.070	1.070	15/16	2	1-5/16	1-15/16	4-3/4	
		1"	1.335	1.335	1-1/16	2-3/8	1-17/32	2	5-5/16	
		1-1/4"	1.680	1.680	1-7/16	2-3/4	1-15/16	2-9/16	6-1/2	
		1-1/2"	1.925	1.925	1-3/4	3-3/8	2-1/4	2-3/4	7-5/16	

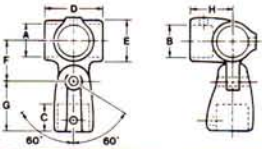
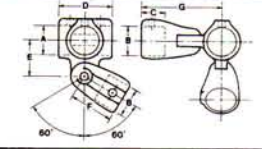
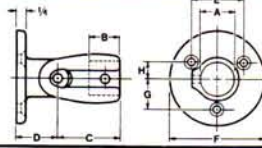
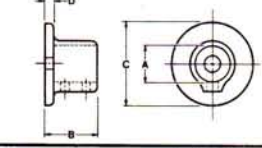
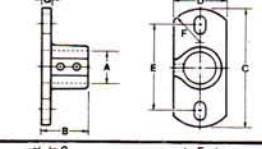
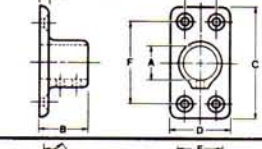
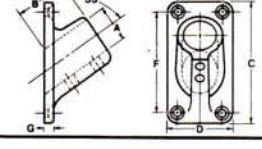
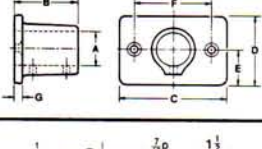
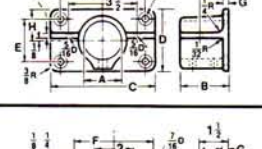
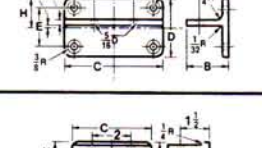
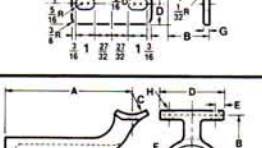
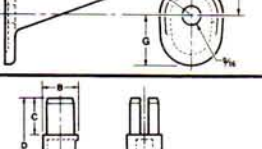
SPEED-RAIL DATA

		I.P.S. SIZE	A	B	C	D	E	F	G	H
No. 25 ADJ. SIDE-OUTLET ELL or TEE		3/4"	1.070	1.070	15/16	2	1-5/16	1-5/16	1-15/16	1-1/2
		1"	1.335	1.335	1-1/16	2-3/8	1-19/32	1-5/8	2	1-25/32
		1-1/4"	1.680	1.680	1-7/16	2-3/4	1-31/32	1-15/16	2-9/16	2
		1-1/2"	1.925	1.925	1-3/4	3-3/8	2-1/4	2-1/4	2-3/4	2-5/16
No. 27 DBL. ADJ. SIDE-OUTLET ELL or TEE		3/4"	1.070	1.070	15/16	2	1-5/16	1-15/16	3-1/4	
		1"	1.335	1.335	1-1/16	2-3/8	1-5/8	2	3-5/8	
		1-1/4"	1.680	1.680	1-7/16	2-3/4	1-15/16	2-9/16	4-1/2	
		1-1/2"	1.925	1.925	1-3/4	3-3/8	2-1/4	2-3/4	5	
No. 41 ADJ. FLANGE		3/4"	1.070	31/32	1-15/16	1-3/16	1-5/8	2-7/8	15/16	15/32
		1"	1.335	1-1/8	2	1-3/16	1-5/8	2-7/8	15/16	15/32
		1-1/4"	1.680	1-7/16	2-9/16	1-5/16	2-1/16	3-3/8	1-3/16	19/32
		1-1/2"	1.925	1-3/4	2-3/4	1-5/16	2-1/16	3-3/8	1-3/16	19/32
No. 43 FLANGE		3/4"	1.070	1-1/2	2-3/8	1/4				
		1"	1.335	1-13/16	2-11/16	1/4				
		1-1/4"	1.680	2-1/8	3-1/16	1/4				
		1-1/2"	1.925	2-17/32	3-7/16	1/4				
No. 46 FLANGE		1-1/4"	1.680	2-3/16	5-3/4	2-1/2	4-1/4	1-3/4	3/8	
		1-1/2"	1.925	2-17/32	5-3/4	2-1/2	4-1/4	1-3/4	3/8	
No. 47 FLANGE		3/4"	1.070	1-1/2	3-1/2	1-7/8	(2 on CL)	2-5/8	1/4	
		1"	1.335	1-13/16	3-1/2	2-3/8	1-7/16	2-5/8	1/4	
		1-1/4"	1.680	2-1/8	4-1/16	2-15/16	1-7/8	3	5/16	
		1-1/2"	1.925	2-17/32	4-5/16	3-1/8	2-1/8	3-1/4	3/8	
No. 47-AF 55° ANGLE FLANGE		3/4"	1.070	1-1/2	3-1/2	1-7/8	1-5/16	2-15/16	1/4	
		1"	1.335	1-13/16	3-1/2	2-3/8	1-13/16	2-15/16	1/4	
		1-1/4"	1.680	2-1/8	4-1/16	2-15/16	2-1/4	3-3/8	1/4	
No. 48 FLANGE		1-1/2"	1.925	3-1/2	6	4	2	4-1/4	7/16	
No. 49 TOE-BOARD FLANGE		1-1/4"	1.680	2-1/8	5-1/16	2-15/16	1-7/8	4-1/16	5/16	1-15/32
		1-1/2"	1.925	2-17/32	5-3/8	3-1/8	2-1/8	4-5/16	5/16	1-9/16
No. 49-A TOE-BOARD BRACKET			—	2-1/8	5-1/16	2-15/16	1-7/8	4-1/16	5/16	1-15/32
No. 49-B TOE-BOARD BRACKET			—	2-1/8	4-1/16	2-1/8	—	—	5/16	1-1/16
No. 82 HANDRAIL BRACKET		1-1/4"	4-1/8"	1-27/32	2	2-1/8	5/16	1-1/16	1-5/8	3/16
						(Fits 1/4" Pipe Handrail)				
No. 84 HANDRAIL RETURN BRACKET		1-1/4"	4-1/8"	1.660	1-3/4	4-3/4	13/16	1-27/32	1-13/32	9/16

Hollaender 1/2" SPEED-RAIL® In-Line Structural Slip-On Fittings

In Std. I.P.S. Pipe Size 1/2" Only
(Shapes different from other sizes of Speed-Rail)

"Instant Structure"™



1/2" SPEED-RAIL DATA

No. 3 ELL

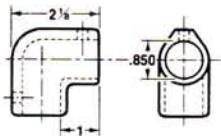

No. 5 TEE

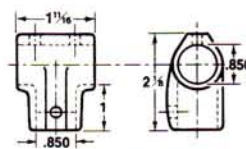

No. 5-AT 55° ANGLE TEE

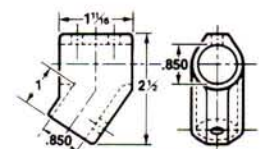

No. 7 CROSS

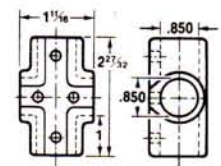

No. 9 SIDE-OUTLET ELL

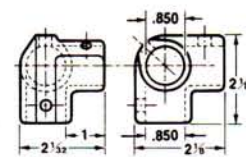

No. 11 SIDE-OUTLET TEE

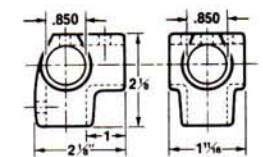

No. 13 SIDE-OUTLET CROSS

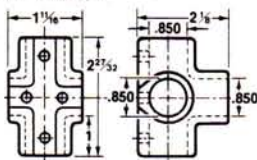

No. 17 ADJUST. ELL or TEE

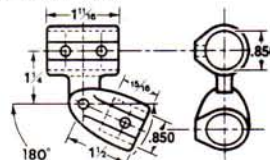

No. 41 ADJUST. FLANGE

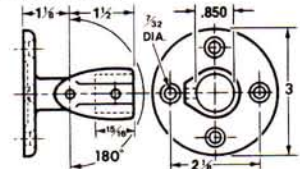

No. 42 FLANGE

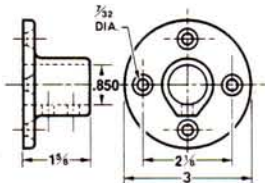

No. 44-AF 55° ANGLE FLANGE

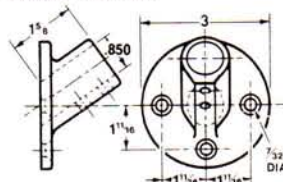

No. 60 PLUG

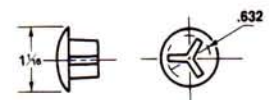

Hollaender NU-RAIL[®]

Offset Structural Slip-On Fittings

In Std. I.P.S. Pipe Sizes: 3/4", 1", 1 1/4", 1 1/2", 2"

"Instant Structure"[™]

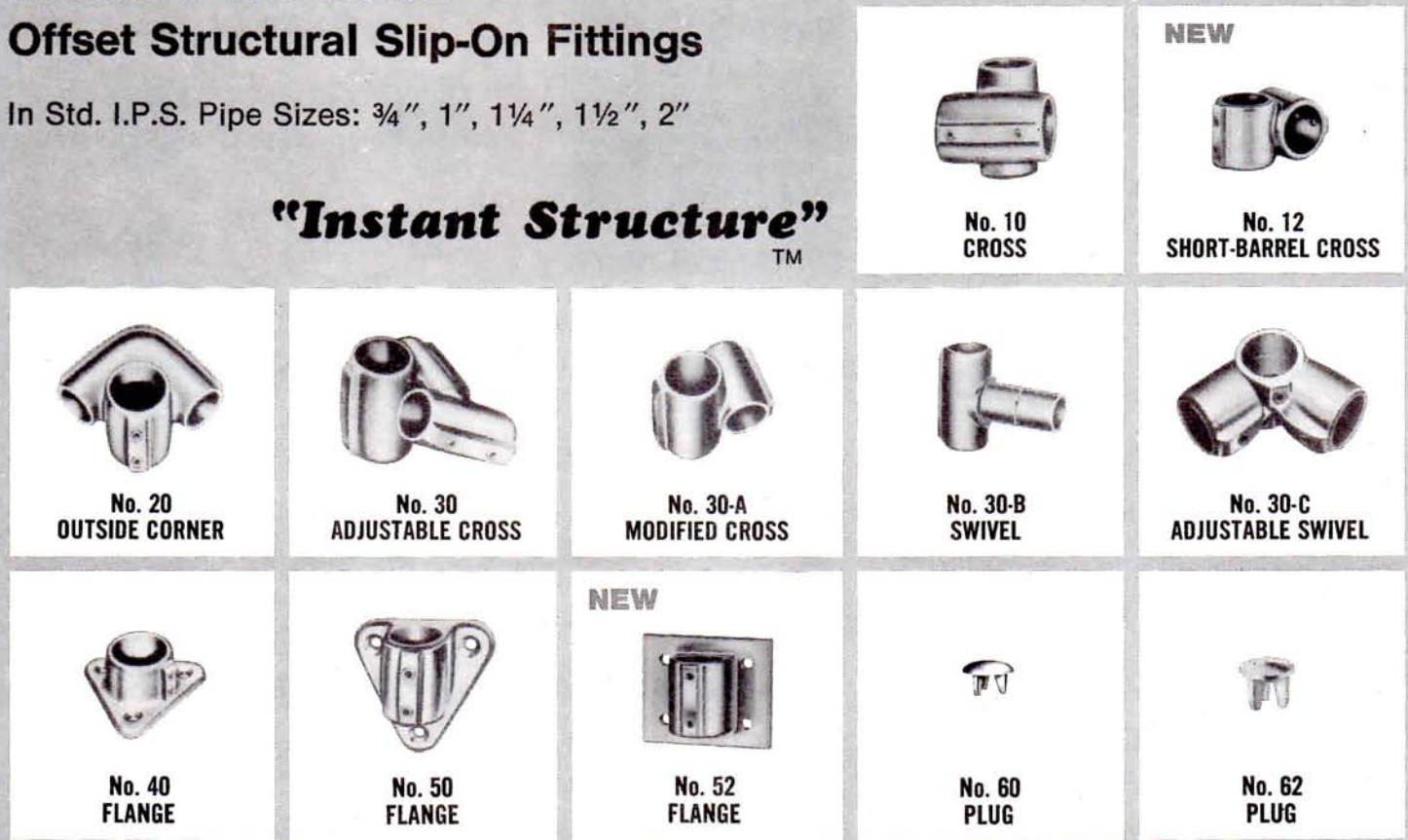

NU-RAIL DATA

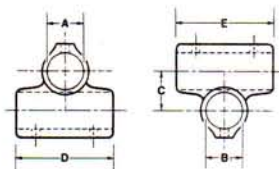
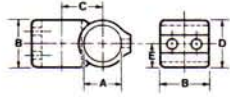
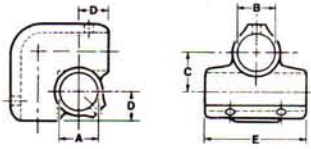
		I.P.S. SIZE	A	B	C	D	E
No. 10 CROSS 		3/4"	1.070	1.070	1-5/32	2-1/2	2-1/2
		1"	1.335	1.335	1-13/32	3-1/2	3-1/2
		1-1/4"	1.680	1.680	1-3/4	3-1/2	3-1/2
		1-1/2"	1.925	1.925	2	3-1/2	3-1/2
		2"	2.400	2.400	2-15/32	4	4
		<i>Reducing Sizes</i>					
		1" x 3/4"	1.335	1.070	1-9/32	2-1/2	3
		1-1/4" x 1"	1.680	1.335	1-37/64	3-1/2	3-1/2
		1-1/2" x 1-1/4"	1.925	1.680	1-7/8	3-1/2	3-1/2
		2" x 1-1/2"	2.400	1.925	2-15/64	3-1/2	4
No. 12 SHORT-BARREL CROSS 		3/4"	1.070	1-15/32	1-3/16	1-13/32	47/64
		1"	1.335	1-27/32	1-7/16	1-25/32	59/64
		1-1/4"	1.680	2-7/32	1-25/32	2-5/32	1-7/64
		1-1/2"	1.925	2-1/2	2-1/32	2-7/16	1-1/4
		(3/4" size has one setscrew in each barrel)					
No. 20 OUTSIDE CORNER 		3/4"	1.070	1.070	1-5/32	3/4	2-1/2
		1"	1.335	1.335	1-13/32	1	3-1/2
		1-1/4"	1.680	1.680	1-3/4	1-3/16	3-1/2
		1-1/2"	1.925	1.925	2	1-5/16	3-1/2
		2"	2.400	2.400	2-15/32	1-9/16	4
		<i>Reducing Sizes</i>					
		1" x 3/4"	1.335	1.070	1-9/32	7/8	3
		1-1/4" x 1"	1.680	1.335	1-37/64	1-3/16	3-1/2
		1-1/2" x 1-1/4"	1.925	1.680	1-7/8	1-5/16	3-1/2
		2" x 1-1/2"	2.400	1.925	2-15/64	1-9/16	4

In **STRAIGHT SIZES**, all barrels have the same I.D.

In **REDUCING SIZES**, horizontal barrels have different I.D. than vertical barrels.

All Fittings are **STRAIGHT SIZES** except where listed as **REDUCING SIZES**.

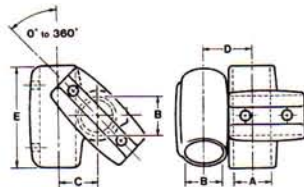
NU-RAIL DATA
**I.P.S.
SIZE**
A
B
C
D
E
F
G
H
**No. 30
ADJUST.
CROSS
(Combines
No. 30-A &
No. 30-B)**

3/4"	1.070	1.070	1-5/32	1-1/4	2-1/2				
1"	1.335	1.335	1-13/32	1-21/32	3-1/2				
1-1/4"	1.680	1.680	1-3/4	2	3-1/2				
1-1/2"	1.925	1.925	2	2-1/4	3-1/2				
2"	2.400	2.400	2-15/32	2-47/64	4				
<i>Reducing Sizes</i>									
1" x 3/4"	1.335	1.070	1-9/32	1-7/16	3				
1-1/4" x 1"	1.680	1.335	1-37/64	1-53/64	3-1/2				
1-1/2" x 1-1/4"	1.925	1.680	1-7/8	2-1/8	3-1/2				
2" x 1-1/2"	2.400	1.925	2-15/64	2-31/64	4				

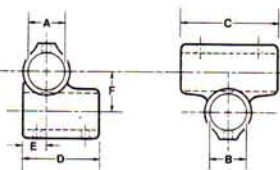
**No. 30-A
MODIFIED
CROSS**

3/4"	1.070	<i>Straight Sizes</i>		2-1/4	11/16	1-5/32			
1"	1.335	1.070	2-1/2	2-3/4	53/64	1-13/32			
1-1/4"	1.680	1.335	3-1/2	2-3/4	1	1-3/4			
1-1/2"	1.925	1.680	3-1/2	3-1/8	1-1/8	2			
2"	2.400	2.400	4	3-23/64	1-23/64	2-15/32			
<i>Reducing Sizes</i>									
1" x 3/4"	1.335	1.070	3	2-1/4	53/64	1-9/32			
1-1/4" x 1"	1.680	1.335	3-1/2	2-3/4	1	1-37/64			
1-1/2" x 1-1/4"	1.925	1.680	3-1/2	2-3/4	1-1/8	1-7/8			
2" x 1-1/2"	2.400	1.925	4	3-1/8	1-23/64	2-15/64			

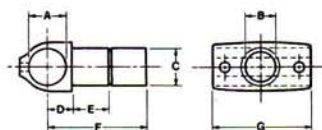
**No. 30-B
SWIVEL**

3/4"	1.070	0.824	1.050	11/16	1-1/16	2-7/8	2-1/2		
1"	1.335	1.049	1.315	53/64	1-3/8	3-33/64	3-1/2		
1-1/4"	1.680	1.380	1.660	1	1-3/8	3-11/16	3-1/2		
1-1/2"	1.925	1.610	1.900	1-1/8	1-9/16	4-3/16	3-1/2		
2"	2.400	2.067	2.375	1-3/8	1-11/16	4-43/64	4		

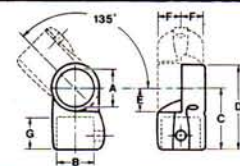
**No. 30-C
ADJUST.
SWIVEL**

3/4"	1.070	1.070	1-7/8	2-9/16	7/8	11/16	1		
1"	1.335	1.335	2-5/16	3-11/64	1-1/16	53/64	1-3/16		
1-1/4"	1.680	1.680	2-25/32	3-55/64	1-9/32	1	1-1/2		
1-1/2"	1.925	1.925	3-1/8	4-19/64	1-1/2	1-1/8	1-5/8		
2"	2.400	2.400	3-1/2	4-31/32	1-3/4	1-3/8	1-3/4		

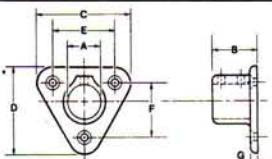
**No. 40
FLANGE**

3/4"	1.070	1-1/2	2-1/2	2-1/4	1-3/4	1-1/2	3/16		
1"	1.335	1-3/4	3-3/16	2-7/8	2-3/16	1-7/8	1/4		
1-1/4"	1.680	1-3/4	3-7/8	3-1/2	2-5/8	2-1/4	1/4		
1-1/2"	1.925	2-1/2	4-3/16	3-13/16	2-15/16	2-9/16	5/16		
2"	2.400	2-1/2	5-1/16	4-1/2	3-13/16	3-1/4	5/16		

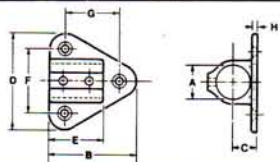
**No. 50
FLANGE**

3/4"	1.070	3-1/4	1	3-1/4	2	2-1/4	2-1/4	3/16	
1"	1.335	3-7/8	1-1/16	3-3/4	2-1/4	2-1/2	2-5/8	1/4	
1-1/4"	1.680	3-7/8	1-7/32	4-1/4	2-1/2	3	2-5/8	1/4	
1-1/2"	1.925	4-1/2	1-3/8	4-1/2	3	3-1/4	3-1/4	5/16	
2"	2.400	4-7/8	1-19/32	5	3-3/8	3-3/4	3-5/8	5/16	

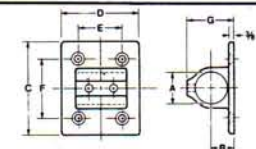
**No. 52
FLANGE**

1-1/2"	1.925	1-3/8	5-1/2	4-1/2	2-1/2	3-1/2	2-25/32		
--------	-------	-------	-------	-------	-------	-------	---------	--	--

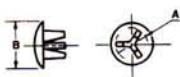
**No. 60
PLUG**

3/4"	0.834	1-5/16							
1"	1.059	1-9/16							
1-1/4"	1.390	1-15/16							
1-1/2"	1.620	2-3/16							
2"	2.077	2-21/32							

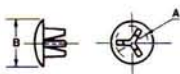
*("B" Dimension
matches O.D. of
Fitting, not Pipe.)*
**No. 62
PLUG**

3/4"	0.834	1.050							
1"	1.059	1.315							
1-1/4"	1.390	1.660							
1-1/2"	1.620	1.900							

*("B" Dimension
matches O.D. of
Pipe, not Fitting.)*

The Versatility of Hollaender **NU-RAIL**[®]

The common sense and practical value inherent in the original Hollaender NU-RAIL line is demonstrated by the fact that the line is essentially unchanged today. Those five original NU-RAIL fittings still serve to join pipe . . . admirably . . . in practically every conceivable offset installation, with the addition only of the proper flanges and plugs.



WITH THESE FIVE NU-RAIL FITTINGS . . . YOU CAN MAKE ALL THESE CONNECTIONS:



No. 10



ELL



TEE



CROSS



No. 20



SIDE-OUTLET ELL



SIDE-OUTLET TEE



No. 30
COMBINATION:
1-No. 30-A
1-No. 30-B



ADJUSTABLE ELL



ADJUSTABLE TEE



ADJUSTABLE CROSS



SIDE-OUTLET ADJUSTABLE ELL



SIDE-OUTLET ADJUSTABLE TEE



SIDE-OUTLET ADJUSTABLE CROSS



COMBINATION:
1-No. 10
2-No. 30-B



DOUBLE ADJUSTABLE ELL



DOUBLE ADJUSTABLE TEE



DOUBLE ADJUSTABLE CROSS



COMBINATION:
1-No. 30-A
1-No. 30-C



ADJUSTABLE
STAIR-LANDING TEE



SIDE-OUTLET ADJUSTABLE
STAIR-LANDING TEE



DOUBLE SIDE-OUTLET ADJUSTABLE
STAIR-LANDING TEE



ADJUSTABLE
STAIR-LANDING CROSS



SIDE-OUTLET ADJUSTABLE
STAIR-LANDING CROSS



DOUBLE SIDE-OUTLET ADJUSTABLE
STAIR-LANDING CROSS

Hollaender RACKMASTER® Offset Structural Slip-On Fittings

In Std. I.P.S. Pipe Sizes: 3/4", 1", 1 1/4", 1 1/2", 2"

"Instant Structure"
TM



**No. 14
SPLIT CROSS**



**No. 45
FLANGE**



**No. 60
PLUG**



**No. 62
PLUG**



**No. 70
COUPLING**



**No. 100
RACKMASTER**



**No. 102
RACKMASTER**



**No. 104
SIDE-OUTLET
CROSS**



**No. 106
DOUBLE SIDE-OUTLET
CROSS**

RACKMASTER DATA

**No. 14
SPLIT
CROSS**

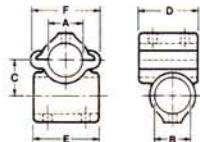

**I.P.S.
SIZE**

1"
1-1/4"
1-1/2"

A

1.335
1.680
1.925

B

1.335
1.680
1.925

C

1-7/16
1-25/32
2-1/32

D

2-1/4
2-5/8
3

E

2-1/2
3
3-1/2

F

2-5/8
3-1/8
3-7/8

**No. 45
FLANGE**

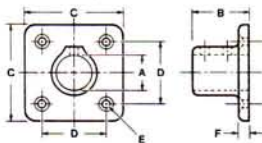

3/4"
1"
1-1/4"
1-1/2"

1.070
1.335
1.680
1.925

1-1/2
1-13/16
2-1/8
2-17/32

2-5/8
3
3-3/8
3-5/8

1-3/4
2-1/16
2-3/8
2-5/8

5/16
5/16
7/16
7/16

1/4
1/4
5/16
5/16

**No. 60
PLUG**

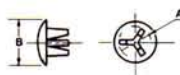

3/4"
1"
1-1/4"
1-1/2"
2"

0.834
1.059
1.390
1.620
2.077

1-5/16
1-9/16
1-15/16
2-3/16
2-21/32

("B" Dimension
matches O.D. of
Fitting, not Pipe.)

**No. 62
PLUG**

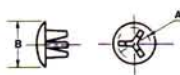

3/4"
1"
1-1/4"
1-1/2"

0.834
1.059
1.390
1.620

1.050
1.315
1.660
1.900

("B" Dimension
matches O.D. of
Pipe, not Fitting.)

RACKMASTER DATA

**No. 70
COUPLING**

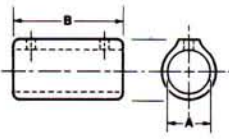

**I.P.S.
SIZE**
3/4"
1"
1-1/4"
1-1/2"
2"

A	B	C	D	E	F	G
1.070	2-1/2					
1.335	3-1/2					
1.680	3-1/2					
1.925	3-1/2					
2.400	4					

**No. 100
RACK-
MASTER**

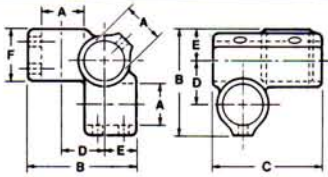

1"
1-1/4"
1-1/2"
2"

1.335	4-1/8	3-1/2	1-15/32	1-19/32	2-1/4	
1.680	4-17/32	3-1/2	1-13/16	1-1/2	2-1/4	
1.925	4-31/32	3-1/2	2-1/16	1-1/2	2-1/4	
2.400	5-21/32	4	2-1/2	1-1/2	2-1/2	

**No. 102
RACK-
MASTER**

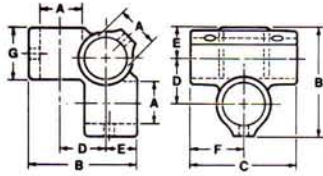

3/4"
1"
1-1/4"
1-1/2"
2"

1.070	2-25/32	2-1/2	1-3/16	3/4	1-1/4	1-5/16
1.335	3-9/16	3-1/2	1-15/32	1-1/32	1-3/4	1-11/16
1.680	4-17/32	3-1/2	1-13/16	1-1/2	1-3/4	2-1/4
1.925	4-25/32	3-1/2	2-1/16	1-5/16	1-3/4	2-1/4
2.400	5-15/32	4	2-1/2	1-5/16	2	2-1/2

**No. 104
SIDE-
OUTLET
CROSS**

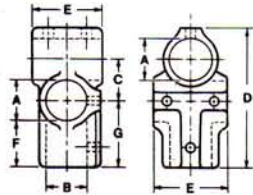

3/4"
1"
1-1/4"
1-1/2"

1.070	1.070	1-3/16	3-13/16	1-7/16	1-1/4	1-25/32
1.335	1.335	1-15/32	4-11/16	2-3/8	1-1/2	2-3/16
1.680	1.680	1-13/16	5-5/8	2-3/8	1-3/4	2-19/32
1.925	1.925	2-1/16	6-7/16	2-1/2	2	2-31/32

(3/4" size has 1 setscrew on all barrels)

**No. 106
DBL. SIDE-
OUTLET
CROSS**

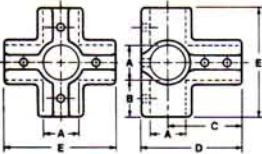

3/4"
1"
1-1/4"
1-1/2"

1.070	1-1/4	2-11/32	3-3/16	3-9/16		
1.335	1-1/2	2-27/32	3-7/8	4-11/32		
1.680	1-3/4	3	4-7/32	5-3/16		
1.925	2	3-5/8	5-1/32	5-15/16		

**TYPICAL APPLICATION OF
WALL-MOUNTED HANDRAIL FITTINGS**

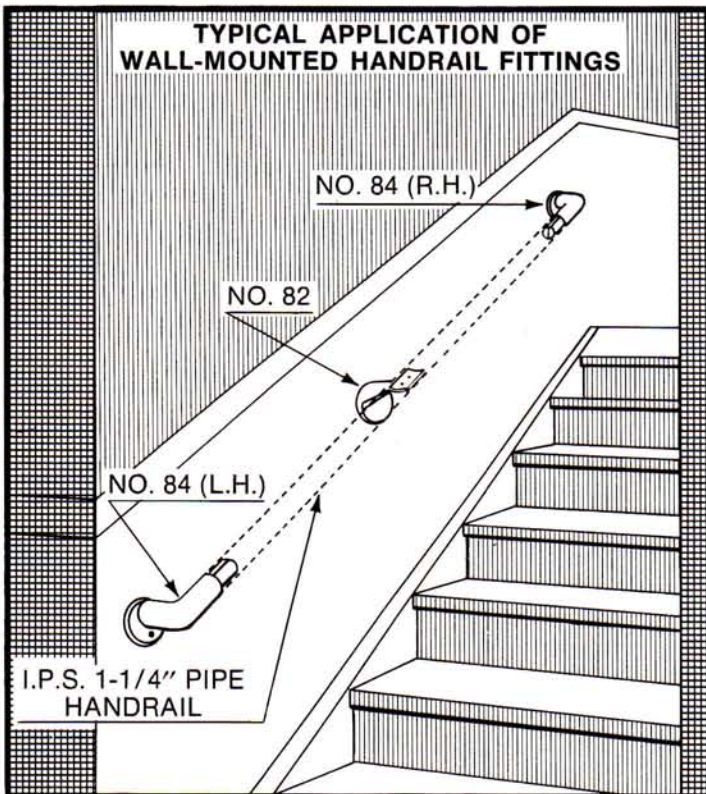

**TYPICAL APPLICATION OF
TOE-BOARD FLANGE & BRACKET FITTINGS**

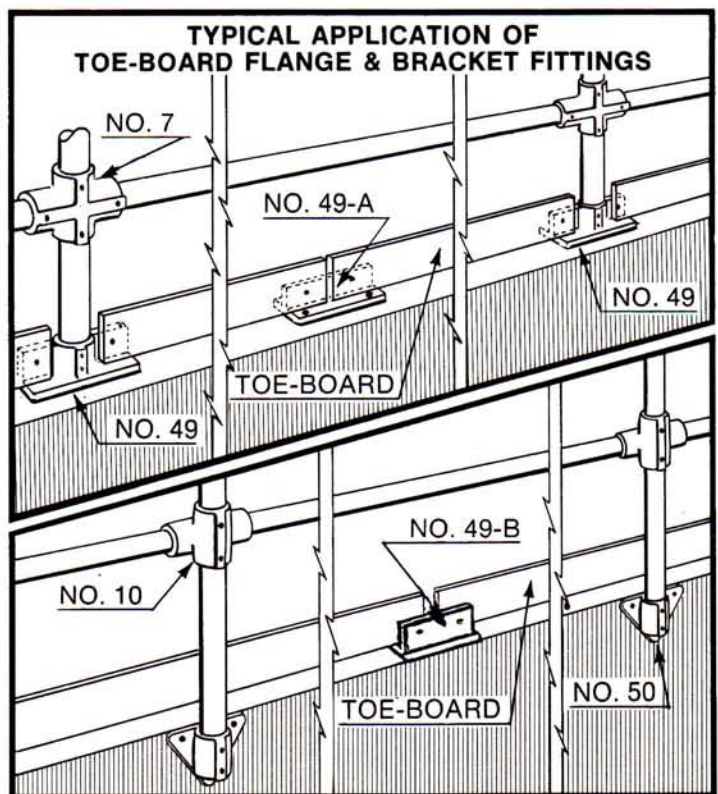

GENERAL REFERENCE TABLES

DIMENSIONS OF STD. I.P.S. PIPE & "INSTANT STRUCTURE"™ FITTINGS

I.P.S. Pipe Size	1/2"	3/4"	1"	1-1/4"	1-1/2"	2"
Pipe I.D.	0.622	0.824	1.049	1.380	1.610	2.067
Pipe O.D.	0.840	1.050	1.315	1.660	1.900	2.375
Fittings I.D.	0.850	1.070	1.335	1.680	1.925	2.400
Setscrew Size	1/4 x 1/4	5/16 x 5/16	3/8 x 3/8	3/8 x 3/8	3/8 x 7/16	3/8 x 7/16
Hex Wrench Size	1/8	5/32	3/16	3/16	3/16	3/16

FLANGE BOLT HOLE DIAMETERS

	No. 40	No. 41	No. 43	No. 45	No. 46	No. 47	No. 47-AF	No. 48	No. 49	No. 50	No. 52
3/4"	5/16	5/16	15/32	5/16	—	5/16*	7/32	—	—	5/16	—
1"	5/16	5/16	15/32	5/16	—	5/16	9/32	—	—	5/16	—
1-1/4"	7/16	7/16	17/32	7/16	5/8 x 1	7/16	11/32	—	7/16	7/16	—
1-1/2"	7/16	7/16	19/32	7/16	5/8 x 1	7/16	—	9/16	7/16	7/16	7/16
2"	7/16	—	—	—	—	—	—	—	—	7/16	—

*3/4" size has 2 bolt holes on center line

LOAD CAPACITIES OF STD. I.P.S. SIZE STEEL PIPE — SCHEDULE 40

SIMPLE BEAM CONSTRUCTION

(Yield Stress 25,000 PSI with two beams supporting a uniformly distributed load.)

Beam Length

Pipe Size	2'	3'	4'	5'	6'	8'	10'
3/4" Sch. 40 I.P.S.	1100	700	500	400	300	250	200
1" Sch. 40 I.P.S.	2100	1400	1050	850	700	500	400
1-1/4" Sch. 40 I.P.S.	3800	2550	1900	1500	1200	900	700
1-1/2" Sch. 40 I.P.S.	6100	4200	3000	2400	2000	1500	1200
2" Sch. 40 I.P.S.	9600	6000	4600	3600	3000	2250	1600

Note 1: Safety factor of 1.9 to 1 provided.

Note 2: The addition of a third beam of the same length and diameter will increase load capacity of the span by 35% of stated capacity.

CANTILEVER CONSTRUCTION

(Yield Stress 25,000 PSI for two cantilever arms supporting a uniformly distributed load.)

Cantilever Length

Pipe Size	1'	2'	3'	4'	5'
3/4" Sch. 40 I.P.S.	600	300	200	160	100
1" Sch. 40 I.P.S.	1100	500	350	300	200
1-1/4" Sch. 40 I.P.S.	1900	1000	650	500	400
1-1/2" Sch. 40 I.P.S.	3100	1500	1000	750	600
2" Sch. 40 I.P.S.	4700	2300	1550	1100	900

Note: Safety factor of 1.9 to 1 is provided.

SIMPLE BEAM CONSTRUCTION

(Yield stress 25,000 PSI with two beams supporting a load concentrated at the center of the clear span)

Beam Length

Pipe Size	2'	3'	4'	5'	6'	7'	8'
3/4" Sch. 40 I.P.S.	300	200	150	Not Recommended			
1" Sch. 40 I.P.S.	550	350	250	200	150	Not Recmd.	
1-1/4" Sch. 40 I.P.S.	950	650	500	400	300	250	200
1-1/2" Sch. 40 I.P.S.	1350	900	650	500	450	400	350
2" Sch. 40 I.P.S.	2400	1500	1150	900	750	650	550

Note: Safety factor of 1.9 to 1 is provided.

CANTILEVER CONSTRUCTION

(Yield stress 25,000 PSI for two cantilever arms supporting a concentrated load at varying distances from the vertical support column)

Cantilever Length

Pipe Size	1'	2'	3'	4'	5'
3/4" Sch. 40 I.P.S.	300	125	75	Not Recommended	
1" Sch. 40 I.P.S.	550	275	200	150	100
1-1/4" Sch. 40 I.P.S.	900	475	325	250	200
1-1/2" Sch. 40 I.P.S.	1350	675	450	325	250
2" Sch. 40 I.P.S.	2100	1150	750	500	450

Note: Safety factor of 1.9 to 1 is provided.

COLUMN LOAD CAPACITY

(Yield Stress 25,000 PSI; Working Stress 12,500 lbs.)

Column Height

Pipe Size	1'	2'	3'	4'	5'	6'	8'
3/4" Sch. 40 I.P.S.	4000	3250	2250	Not Recommended			
1" Sch. 40 I.P.S.	6000	5250	4250	3000	Not Recommended		
1-1/4" Sch. 40 I.P.S.	8250	7500	7000	5750	Not Recom'd		
1-1/2" Sch. 40 I.P.S.	9750	9500	8750	7500	6250	4750	Not
2" Sch. 40 I.P.S.	13,250	12,500	12,000	11,250	10,250	9000	Rec.

Note 1: Values shown are for EACH COLUMN in the structure.

Note 2: A column is deemed to exist from the floor line to the first horizontal load bed, or between any two load beds attached to the columns.

Example: A rack 4' high with load beds at 2' and 4' from floor, is made up of eight 2' columns even though overall length of each upright = 4'.

LOAD CAPACITIES OF FITTINGS SETSCREWS

WHEN PROPERLY TORQUED

Fitting Size	Torque Ft. Lbs.	No. Screws	Load Capacity
3/4"	12.5 lbs.	2	1900 lbs.
3/4"	12.5 lbs.	1	1000 lbs.
1"	14.2 lbs.	2	1800 lbs.
1"	14.2 lbs.	1	1200 lbs.
1-1/4"	16.7 lbs.	2	3100 lbs.
1-1/4"	16.7 lbs.	1	2300 lbs.
1-1/2"	22.5 lbs.	2	2350 lbs.
2"	22.5 lbs.	2	3200 lbs.

Above data compiled by an independent laboratory using the following test procedures:

Standard I.P.S. — sized pipe within the vertical barrel of the test fittings, to the torque shown above. A 30,000 lb. Universal Testing Machine applied vertical load to the pipe member in an attempt to produce pipe slippage. Load capacities listed above are based on a safety factor of 100%.

Shipping Weights of Speed-Rail®, Nu-Rail® and Rackmaster® Fittings in Pounds

SPEED-RAIL®

No. 3	3/4"	1"	1-1/4"	1-1/2"	2"
5	0.188	0.313	0.438	0.695	—
5 - AT	0.187	0.320	0.510	—	—
7	0.234	0.406	0.508	0.844	—
9	0.258	0.422	0.578	0.813	—
11	0.234	0.375	0.500	0.703	—
13	0.281	0.422	0.625	0.900	—
17	0.317	0.469	0.688	0.844	—
19	0.531	0.766	1.125	1.438	—
21 - 35°	0.312	0.472	0.687	0.920	—
21 - 45°	0.360	0.600	0.875	1.100	—
23	0.383	0.547	0.844	1.125	—
25	0.383	0.578	0.844	1.125	—
27	0.578	0.766	1.141	1.469	—
41	0.359	0.406	0.625	0.720	—
43	0.188	0.258	0.422	0.531	—
46	—	—	0.610	0.645	—
47	0.219	0.281	0.469	0.656	0.938
47 - AF	0.240	0.370	0.595	—	—
48	—	—	—	1.937	—
49	—	—	0.690	0.940	—
49 - A	—	0.450	—	—	—
49 - B	—	0.420	—	—	—

	3/4"	1"	1-1/4"	1-1/2"	2"
60	0.031	0.046	0.078	0.093	0.156
62	0.031	0.072	0.103	0.125	—
82		0.410			
84		0.750			

1/2" SPEED-RAIL®

(Shapes different from other sizes of Speed-Rail)

No. 3	0.165	No. 13	0.210
5	0.135	17	0.200
5 - AT	0.155	41	0.260
7	0.187	42	0.225
9	0.180	44 - AF	0.250
11	0.165	60	0.015

NU-RAIL® Straight Sizes

No. 10	3/4"	1"	1-1/4"	1-1/2"	2"
12	0.187	0.395	0.600	0.885	—
20	0.380	0.740	0.963	1.437	2.200
30	0.520	1.005	1.300	1.746	2.546
30A	0.280	0.555	0.710	0.916	1.380
30B	0.240	0.450	0.590	0.830	1.166
30C	0.280	0.432	0.770	1.020	1.660
40	0.125	0.280	0.330	0.500	0.673

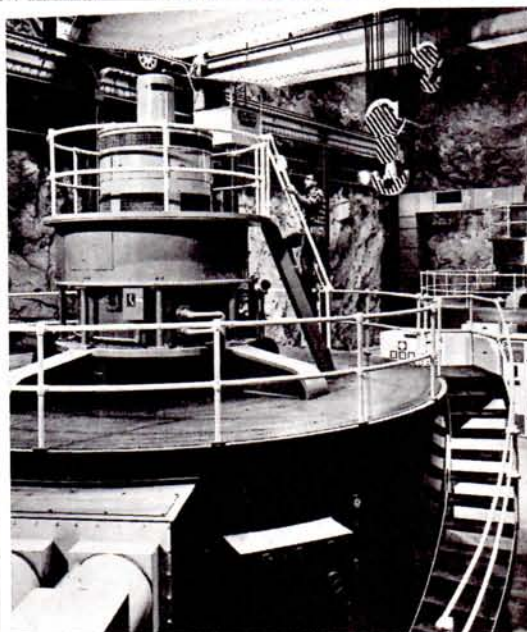
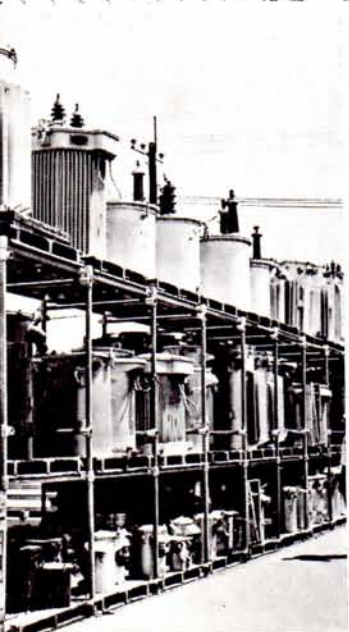

**Typical Installations
with
SPEED-RAIL, NU-RAIL & RACKMASTER**



	3/4"	1"	1-1/4"	1-1/2"	2"
50	0.250	0.400	0.510	0.790	1.083
52	—	—	—	1.250	—
60	0.031	0.046	0.078	0.093	0.156
62	0.031	0.072	0.103	0.125	—

NU-RAIL® Reducing Sizes

	1" x 3/4"	1-1/4" x 1"	1-1/2" x 1-1/4"	2" x 1-1/2"
No. 10	0.375	0.660	0.916	1.250
20	0.500	0.815	1.217	1.870
30	0.615	1.160	1.510	2.116
30A	0.375	0.710	0.800	1.200

RACKMASTER®

	3/4"	1"	1-1/4"	1-1/2"	2"
No. 14	—	0.689	0.906	1.438	—
45	0.240	0.375	0.460	0.625	—
60	0.031	0.046	0.078	0.093	0.156
62	0.031	0.072	0.103	0.125	—
70	0.187	0.375	0.437	0.625	0.725
100	—	0.906	1.062	1.334	2.063
102	0.313	0.625	1.093	1.125	1.906
104	0.281	0.719	0.875	1.250	—
106	0.500	1.000	1.125	2.000	—

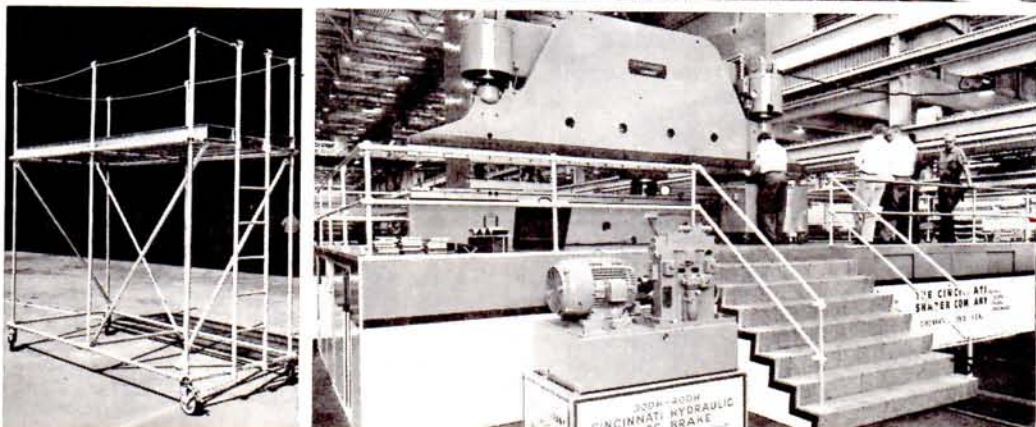
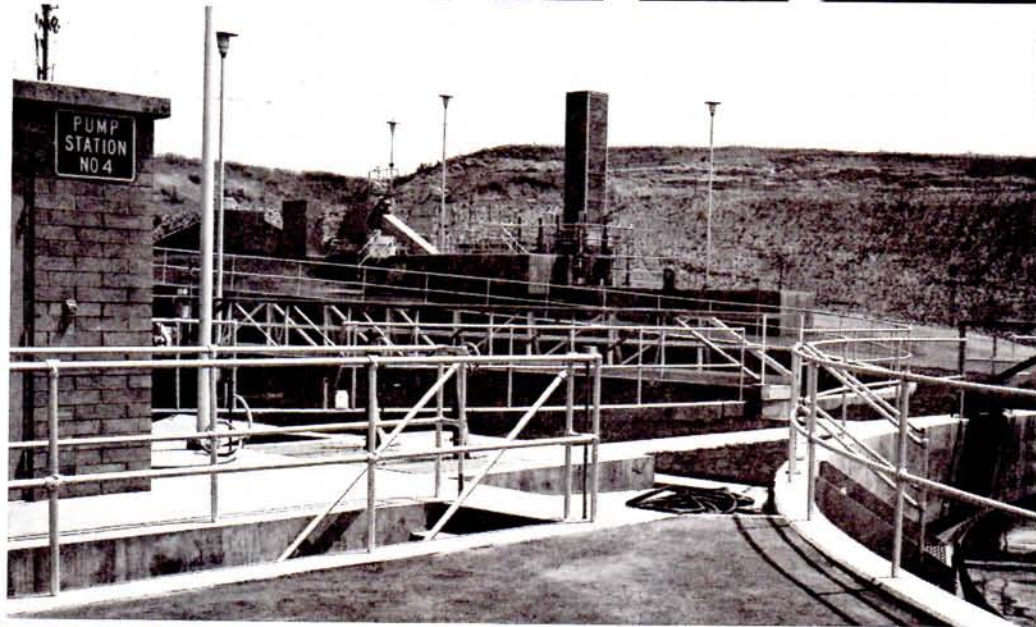
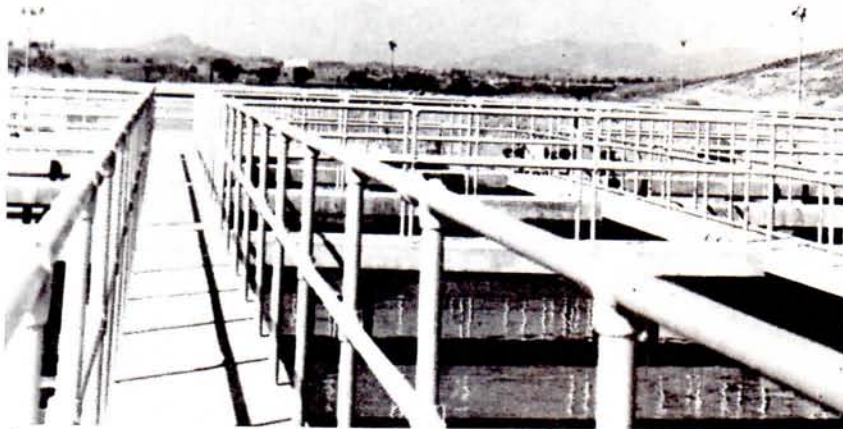
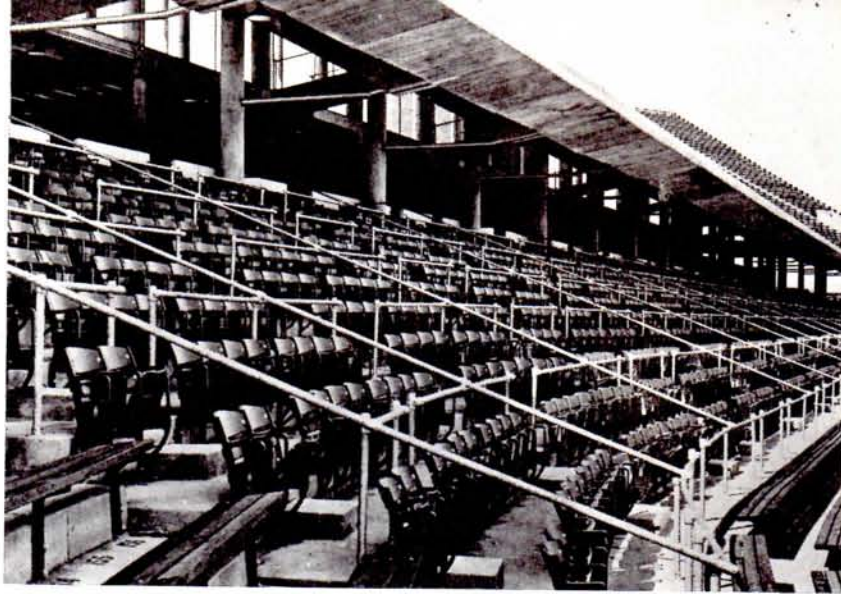

HOLLAENDER

**"Instant
Structure"**
TM

with **SPEED-RAIL,[®] NU-RAIL[®] &
RACKMASTER[®] FITTINGS...**

...the easy, cost & time-saving,
best-looking way to

BUILD WITH PIPE

Originators &
Manufacturers

THE
**HOLLAENDER
MFG. COMPANY**

3841 Spring Grove Ave.
Cincinnati, Ohio 45223
Phone: 513/681-3040

ADDRESS IS
10233 Wayne Avenue
Cincinnati, Ohio 45215
Phone: 513/772-8800