

# AAC

ADVANCE AUTOMATION COMPANY

SPECIALISTS IN THE MANUFACTURE OF ALUMINUM AIR CYLINDERS

**SALES  
&  
SERVICE**

**ADVANCED FLUID POWER, INC.**

I-10 INDUSTRIAL PARK  
THEODORE (MOBILE), AL 36582  
(334) 653-6888

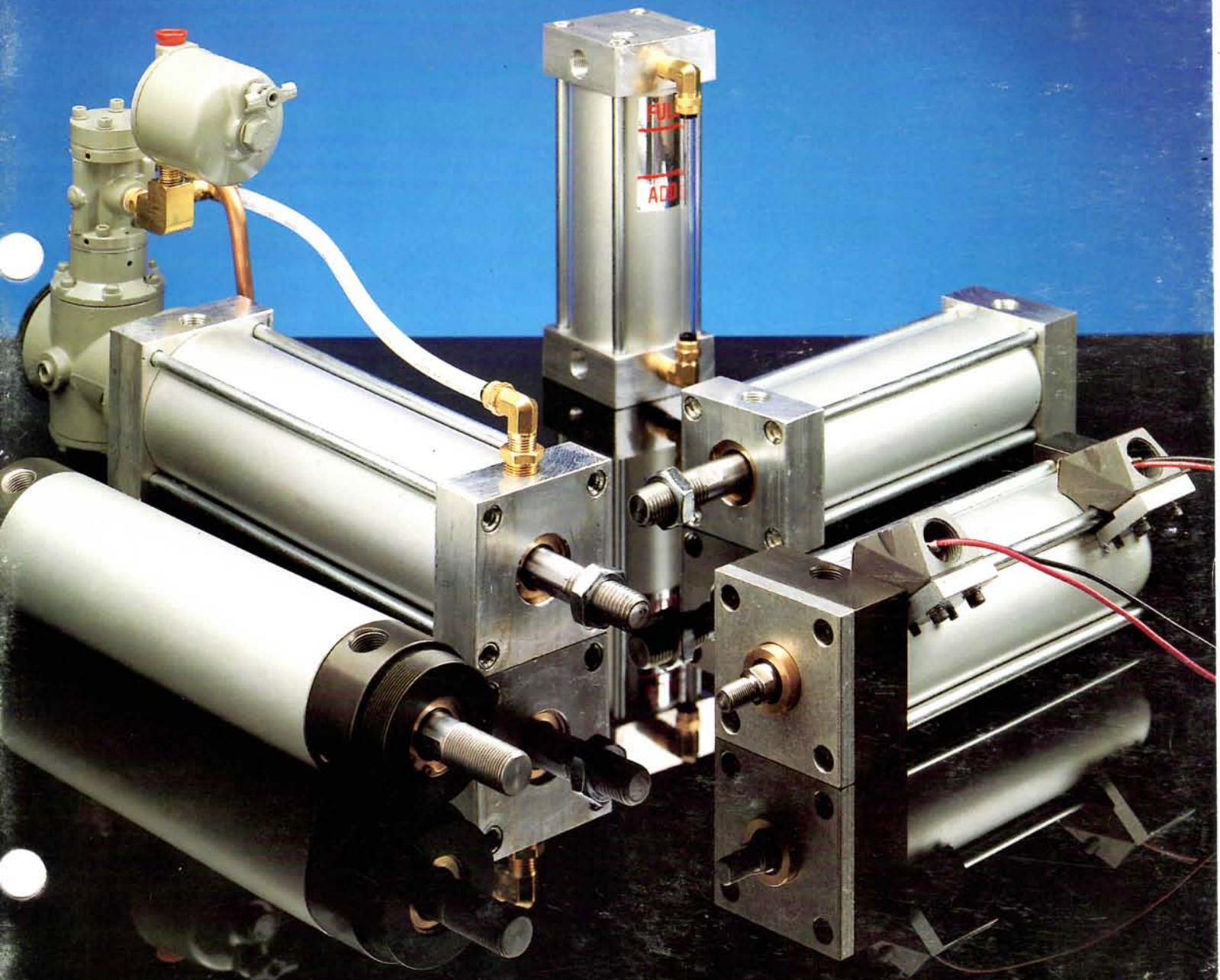



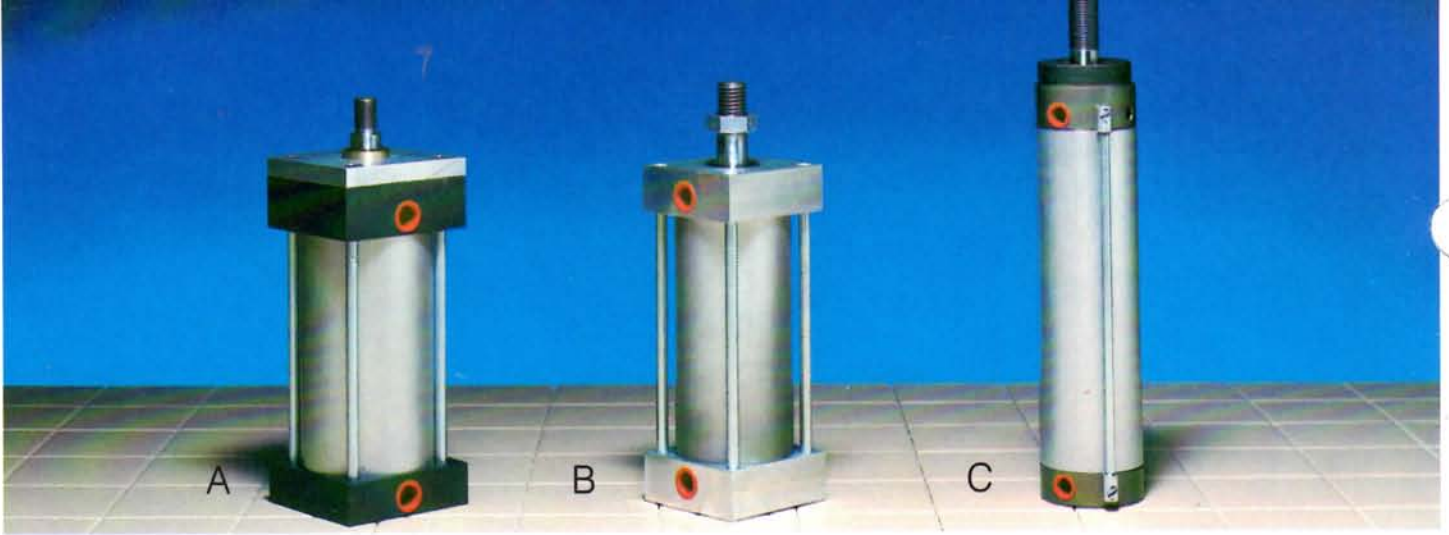

#### A. Series I Cylinder

- NFPA Interchangeable
- 1 1/2" through 8" bores
- 250 PSI pneumatic and non-shock hydraulic
- Hard coated, anodized heads and caps as standard (optional on 6" & 8" bores)
- Unique urethane cushion cup design (optional)
- Most mounts bolt-on

#### B. Series B & J Cylinder

- OEM Economy Line
- 1 1/4" through 8" bores
- 250 PSI pneumatic and non-shock hydraulic
- Oversize rod diameter

#### C. Series R Cylinder

- Space Saving Applications
- 1 3/4" through 3" bores
- 250 PSI pneumatic and non-shock hydraulic
- Unique urethane cushion cup design (optional)
- Corrosion resistant as standard

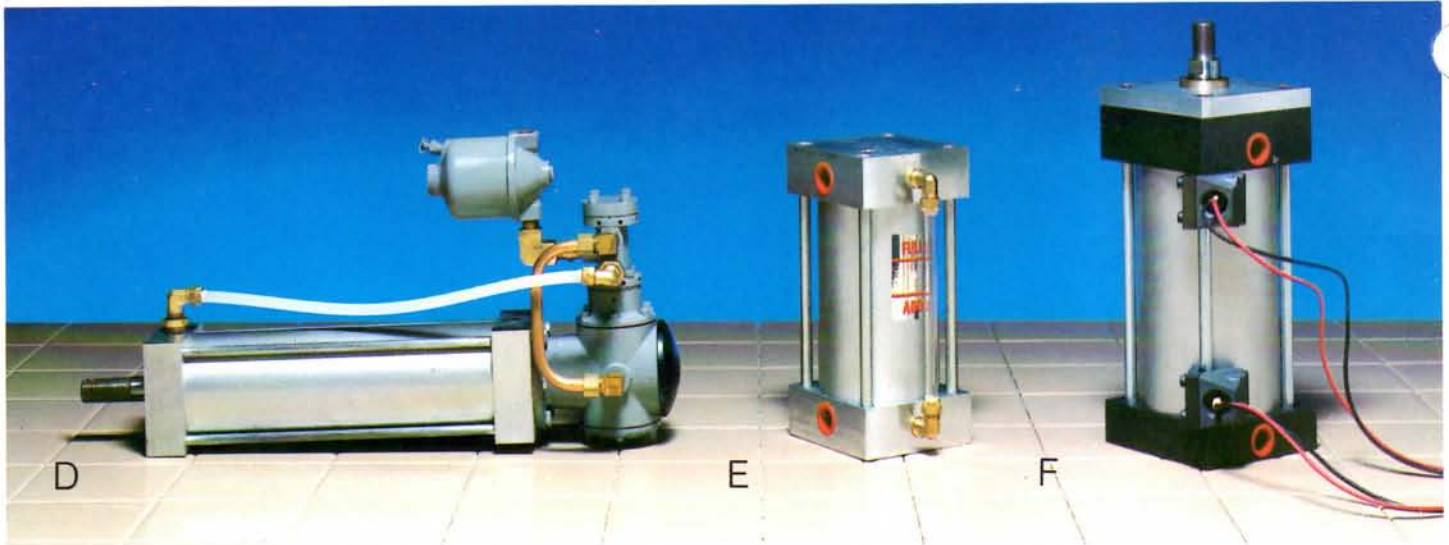

#### D. Series AP Actuator Positioner

- Process Control Device
- Utilized with Series B & J
- 2 1/2" through 8" bores
- 2" through 14" strokes
- 250 PSI pneumatic
- 3 models available

#### E. Series T Air-Oil Tank

- 2 1/2" through 8" bores
- 250 PSI hydraulic
- 90° internal baffles
- Shatterproof sight gauge
- Fill and drain plugs
- NFPA porting

#### F. Series LS Magno Reed Limit Switches

- Originators of reed limit switch
- 6 models available
- 3 models UL listed
- Indicator light feature available

# INDEX

CONTENTS	PAGE NUMBER
Company History .....	2
<b>Series I Cylinders (NFPA Interchangeable)</b> .....	3
Series I Material and Design Specifications .....	4
Series I Ordering Instructions .....	5
Series I Dimensions .....	6-7
Series I 1 1/2" through 5" Bore NFPA Mounting Styles .....	8-9
Series I 6" and 8" Bore NFPA Mounting Styles .....	10-11
Series I Accessories .....	12
Series I Multiple Position Cylinders .....	13-14
Series I Parts List .....	15
Series I Bore Size Selection .....	16
Series I Rod Diameter Selection .....	17
Stop Tube Selection for Series I, B & J, and R Cylinders .....	17
Common Cylinder Options for Series I, B & J, and R Cylinders .....	18-20
<b>Series B &amp; J Cylinders (OEM Economy Line)</b> .....	21
Series B & J Material and Design Specifications .....	22
Series B & J Ordering Instructions .....	23
Series B & J Dimensions .....	24-25
Series B & J Mounting Options .....	26-27
Series B & J Accessories .....	28
Series B & J Multiple Position Cylinders .....	29-30
Series B Tandem Common Rod Cylinders .....	31
Series B & J Parts List .....	32
<b>Series R Cylinders (Space Saver)</b> .....	33
Series R Material and Design Specifications .....	34
Series R Ordering Instructions .....	35
Series R Cylinder and Accessories Dimensions .....	36-37
Series R Parts List .....	38
<b>Series AP Actuator Positioners</b> .....	39
Series AP Description and Dimensions .....	40-41
Series AP Specifications .....	41-42
Series AP Ordering Instructions .....	42
<b>Series T Air-Oil Tanks</b> .....	43
Series T Selection and Dimensions .....	44-45
Series T Dual Tank Air-Oil System .....	46
Series T Ordering Instructions .....	46
<b>Series LS Magno Reed Limit Switches</b> .....	47
Series LS Ordering Instructions .....	48
Series LS Description .....	49
Series LS Switch Ratings .....	50
Series LS Switch Selection, Specifications, and Installation .....	51
Series LS Indicator Light Switch Description .....	52
Series LS Indicator Light Switch Specifications .....	53
Series LS Contact Protection Circuits .....	54
<b>Series ARC Linear Alignment Coupler</b> .....	55
Series ARC Specifications .....	55
Installation and Maintenance Information for Series I, B & J, and R Cylinders .....	56
	57





## The History of Advance Automation Company

Advance Automation Company began in 1960 with one man's vision to provide the marketplace with a superior air cylinder that incorporated the "advance design" concept. The "advance design" concept utilizes:

- high-grade extruded aluminum caps and heads
- cast bronze bushing for high tensile strength
- nylon piston bearing strip for better wear and stability
- unique cushion design

Since its inception, the company played an integral role in setting the standards for today's aluminum cylinder industry. The founder co-innovated the first aluminum-bodied cylinder as a lightweight and cost effective alternative to the steel-bodied cylinders on the market at that time.

The first cylinders that the company developed and manufactured were the Series B & J OEM economy cylinders. These cylinders have provided manufacturers with millions of trouble-free cycles at the best value possible. Today, Advance Automation remains one of the few manufacturers offering this type of cylinder.

In keeping with the company's reputation as an industry pioneer, the founder originated the reed limit switch. Advance Automation Company is the switch supplier of choice for other cylinder manufacturers because of its superior design. The majority of Advance Automation's switches are UL approved.

Advance Automation Company responded to industry demand by expanding its product line. The company, located in Chicago, Illinois, outgrew its original location on Sangamon Street and moved to its current headquarters on Elston Avenue (not far from Wrigley Field!) in 1965. In the early 1970's, Advance Automation Company designed its version of the space saving round-bodied cylinder, the Series R cylinder, and the actuator/positioner process control device, the Series AP. In the mid 1970's, the company introduced its NFPA interchangeable cylinder, the Series I cylinder. Today, thousands of Advance Automation Company cylinders are meeting a wide variety of fluid power applications in industries such as packaging, automotive, dairy and car wash.

Advance Automation Company adheres to high standards in product quality as well as service. The company prides itself on outstanding quality control. An inspector tests **each** completed cylinder before it leaves the facility. These exacting standards are the reason that the company's return rate is so minimal.

As large corporations have bought and sold other cylinder manufacturers over the years, Advance Automation Company remains a privately held business. This management continuity and stability, along with the firm's size, allows it to maintain a consistent delivery schedule and quick response time. Competitive pricing and reliability have earned Advance Automation an excellent reputation in the industry.

As other manufacturers have attempted to "be all things to all people," Advance Automation Company has remained focused on its core business: **providing the best air cylinder available to solve its customers' fluid power problems.**



# SERIES I

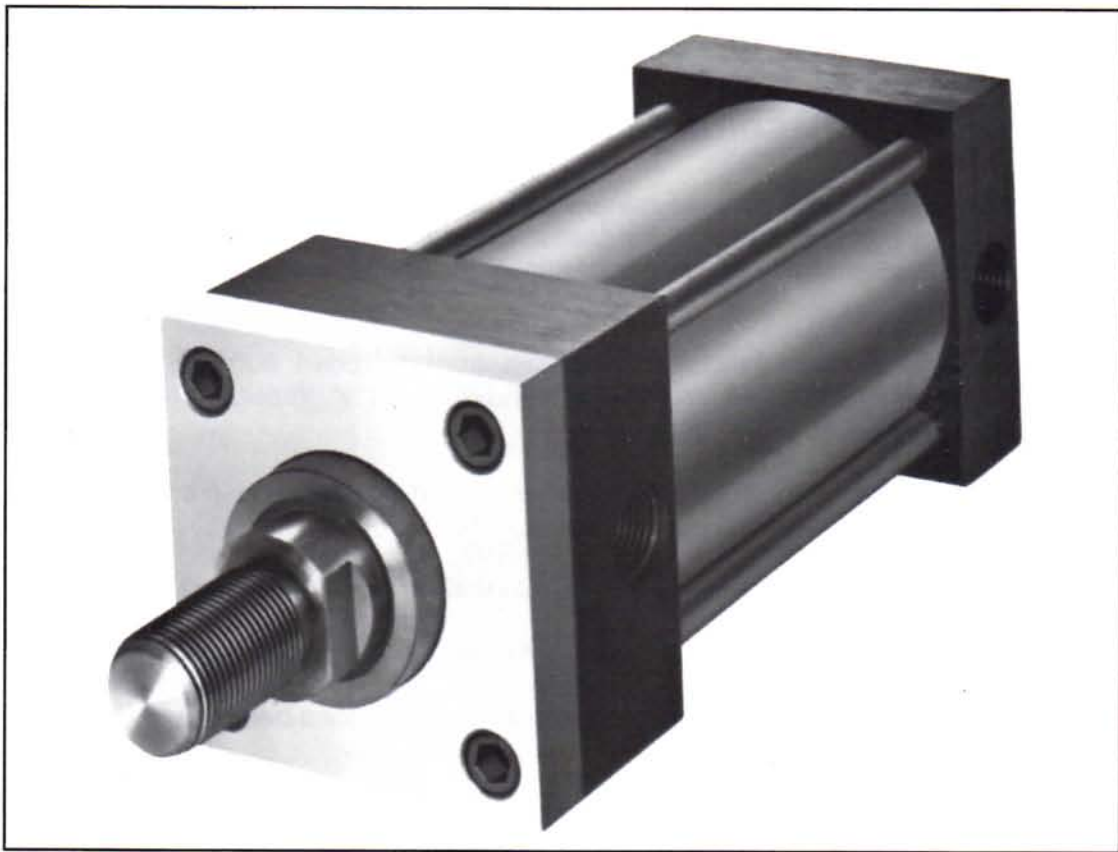

**NFPA Interchangeable  
1 1/2" - 8" Bores  
250 PSI Pneumatic  
250 PSI Non-Shock Hydraulic**



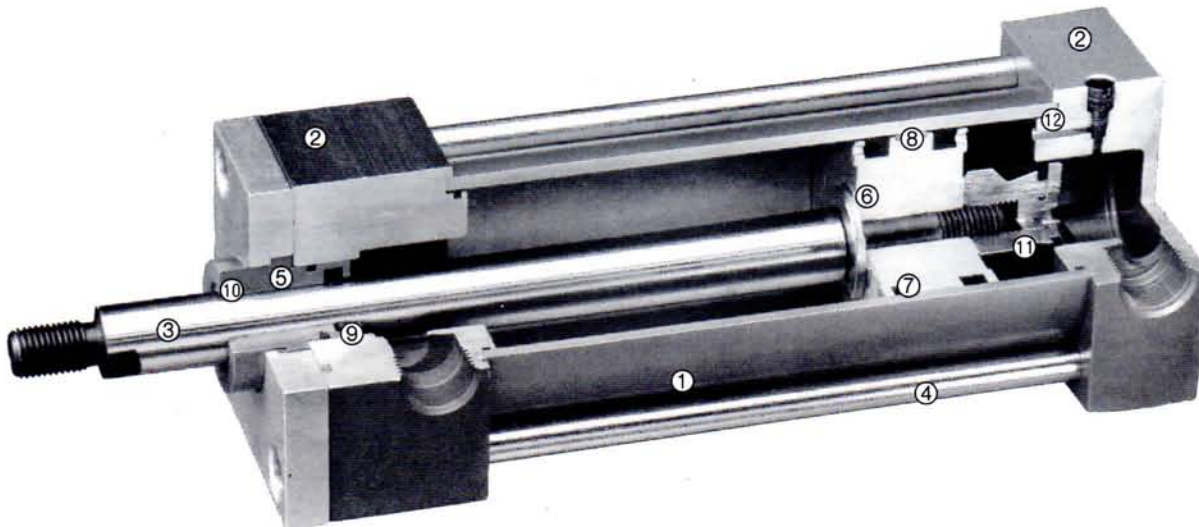

### **SERIES I MATERIAL AND DESIGN SPECIFICATIONS**

1. **Tube:** 6063-T832 grade aluminum alloy with hard coated I.D. This anodic coating provides extreme hardness, excellent wear, low coefficient of friction, and high corrosion resistance to ensure longer, trouble-free cycle life.
2. **Head and Cap:** Precision machined from extruded 6061-T6 grade aluminum alloy. Hard coated as standard on 1½" through 5" bores. (Optional on 6" and 8" bores.)
3. **Piston Rod:** Hard chrome plated steel ground and polished to a smooth finish.
4. **Tie Rods:** High strength 1215 grade zinc clear chromate plated steel.
5. **Rod Bushing:** Continuous cast SAE 660 grade bronze bushing is piloted into the head and is securely held in with an aluminum retaining plate (1½" through 5" bores) to provide maximum load bearing support.
6. **Piston:** High grade aluminum alloy.
7. **Piston Seals:** Block-Vee type, Buna N material is furnished as standard.
8. **Piston Bearing Strip:** A low friction, dimensionally stable nylon wear band constitutes an excellent bearing surface.
9. **Rod Seal:** Block-Vee type is self-adjusting to ensure proper seal.
10. **Rod Wiper:** Lip type urethane seal cleans piston rod and prevents foreign particles from entering cylinder.
11. **Cushion:** Self-adjusting urethane cup moves into the head/cap to insure a positive seal and allows air to meter across the cushion screw. This method provides a fast breakaway and more precise adjustment. (Optional)
12. **Tube Seal:** Buna N "O" ring in head and cap provides tight seal.



## ORDERING INSTRUCTIONS FOR SERIES I CYLINDERS

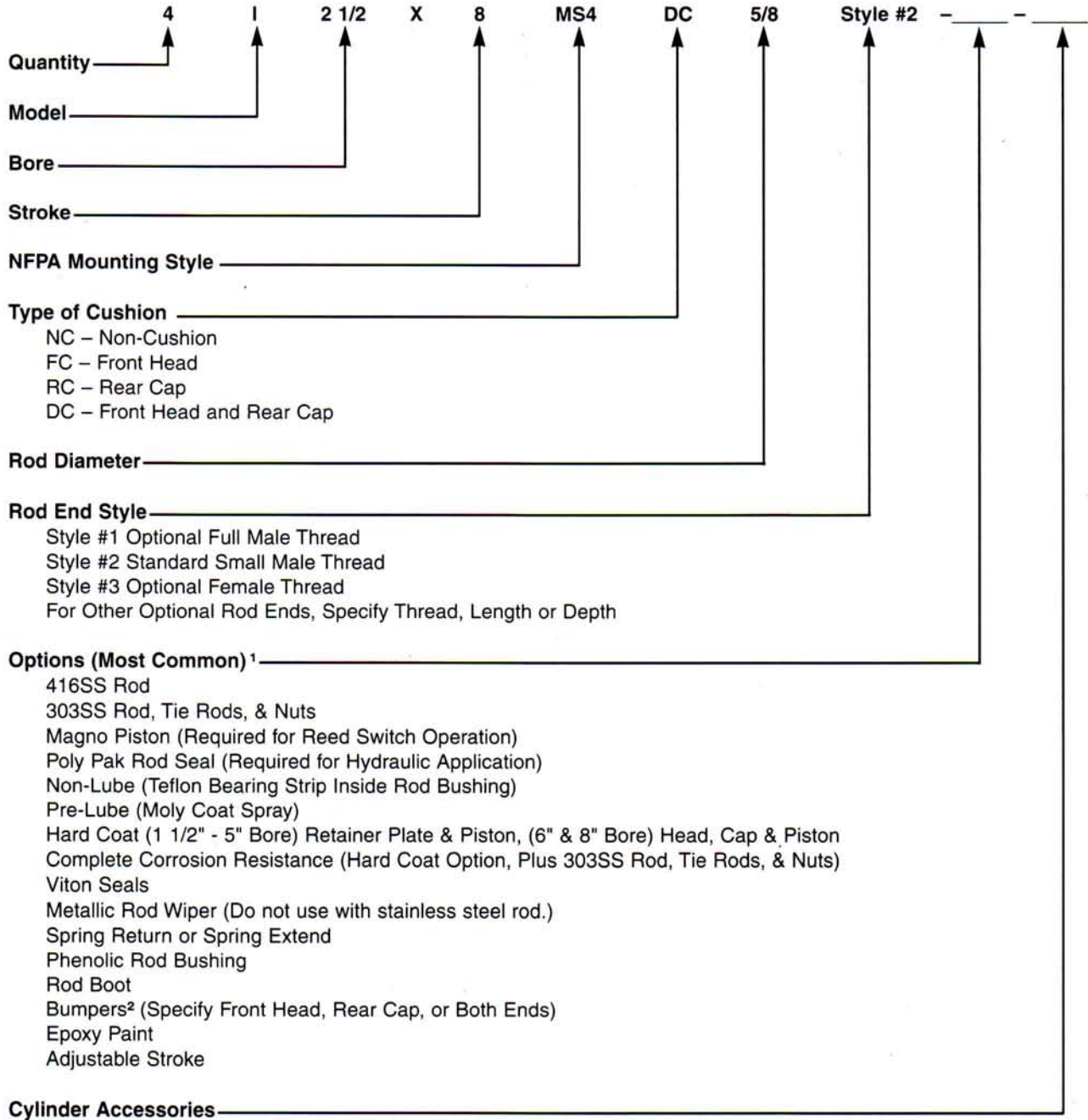

Ports at Position #1 and MS4 (Side Tapped) at Position #3 are standard in all cylinders.

Cushion Screw at Position #4 is standard.

**Note:** If not specified, AAC will assume cylinder desired is MS4 mount, non-cushion, standard rod diameter and rod end style, hard chrome plated steel rod, Buna N seals, and ports at #1.

<sup>1</sup> Consult factory for other options not listed.

<sup>2</sup> Bumpers increase cylinder length. Consult factory.



# SERIES I CYLINDER DIMENSIONS

BORE	1½		2		2½		3¼		4		5		6		8	
ROD DIA.	5/8	5/8	1	5/8	1	1	1 3/8	1	1 3/8	1	1 3/8	1 3/8	1 1/2	1 3/8	1 1/2	
A	¾	¾	1 1/8	¾	1 1/8	1 1/8	1 5/8	1 1/8	1 5/8	1 1/8	1 5/8	1 5/8	2	1 5/8	2	
AA	2.02	2.60	2.60	3.10	3.10	3.90	3.90	4.70	4.70	5.80	5.80	6.90	6.90	9.10	9.10	
AB	7/16	7/16	7/16	7/16	7/16	9/16	9/16	9/16	9/16	1 1/16	1 1/16	—	—	—	—	
AH	1 3/16	1 7/16	1 7/16	1 5/8	1 5/8	1 15/16	1 15/16	2 1/4	2 1/4	2 3/4	2 3/4	—	—	—	—	
AL	1	1	1	1	1	1 1/4	1 1/4	1 1/4	1 1/4	1 3/8	1 3/8	—	—	—	—	
AO	1/2	1/2	1/2	1/2	1/2	1/2	1/2	1/2	1/2	5/8	5/8	—	—	—	—	
AT	3/16	3/16	3/16	3/16	3/16	1/4	1/4	1/4	1/4	1/4	1/4	—	—	—	—	
B	1 1/8	1 1/8	1 1/2	1 1/8	1 1/2	1 1/2	2	1 1/2	2	1 1/2	2	2	2	2	2	
BB	1	1 1/8	1 1/8	1 1/8	1 1/8	1 3/8	1 3/8	1 3/8	1 3/8	1 13/16	1 13/16	1 13/16	1 13/16	2 5/16	2 5/16	
BD	1	1 3/16	1 3/16	1 3/16	1 3/16	1 1/4	1 1/4	1 1/4	1 1/4	1 1/2	1 1/2	1 1/2	1 1/2	—	—	
C	3/8	3/8	1/2	3/8	1/2	1/2	5/8	1/2	5/8	1/2	5/8	1 5/16	1 9/16	1 5/16	1 9/16	
CB	¾	¾	¾	¾	¾	1 1/4	1 1/4	1 1/4	1 1/4	1 1/4	1 1/4	1 1/2	1 1/2	1 1/2	1 1/2	
CD	1/2	1/2	1/2	1/2	1/2	¾	¾	¾	¾	¾	¾	1	1	1	1	
CW	1/2	1/2	1/2	1/2	1/2	5/8	5/8	5/8	5/8	5/8	5/8	¾	¾	¾	¾	
D	1/2	1/2	7/8	1/2	7/8	7/8	1 1/8	7/8	1 1/8	7/8	1 1/8	1 1/4	1 1/4	1 1/4	1 1/4	
DD	1/4-28	5/16-24	5/16-24	5/16-24	5/16-24	3/8-24	3/8-24	3/8-24	3/8-24	1/2-20	1/2-20	1/2-20	1/2-20	5/8-18	5/8-18	
E	2	2 1/2	2 1/2	3	3	3 3/4	3 3/4	4 1/2	4 1/2	5 1/2	5 1/2	6 1/2	6 1/2	8 1/2	8 1/2	
EB	5/16	3/8	3/8	3/8	3/8	7/16	7/16	7/16	7/16	9/16	9/16	—	—	—	—	
EE	3/8	3/8	3/8	3/8	3/8	1/2	1/2	1/2	1/2	1/2	1/2	¾	¾	¾	¾	
EL	¾	1 5/16	1 5/16	1 1/16	1 1/16	7/8	7/8	1	1	1 1/16	1 1/16	—	—	—	—	
EO	1 1/32	5/16	5/16	5/16	5/16	3/8	3/8	3/8	3/8	1/2	1/2	—	—	—	—	
ET	9/16	1 1/16	1 1/16	¾	¾	1	1	1 1/8	1 1/8	1 3/8	1 3/8	—	—	—	—	
F	3/8	3/8	3/8	3/8	3/8	5/8	5/8	5/8	5/8	5/8	5/8	¾	¾	—	—	
FB	5/16	3/8	3/8	3/8	3/8	7/16	7/16	7/16	7/16	9/16	9/16	9/16	9/16	1 1/16	1 1/16	
G	1 3/8	1 3/8	1 3/8	1 3/8	1 3/8	1 5/8	1 5/8	1 5/8	1 5/8	1 5/8	1 5/8	2	2	2	2	
J	1	1	1	1	1	1 1/4	1 1/4	1 1/4	1 1/4	1 1/4	1 1/4	1 1/2	1 1/2	1 1/2	1 1/2	
K	5/32	3/16	3/16	3/16	3/16	7/32	7/32	7/32	7/32	5/16	5/16	5/16	5/16	3/8	3/8	
KK	7/16-20	7/16-20	¾-16	7/16-20	¾-16	¾-16	1-14	¾-16	1-14	¾-16	1-14	1-14	1 1/4-12	1-14	1 1/4-12	
KK-1	5/8-18	5/8-18	1-14	5/8-18	1-14	1-14	1 3/8-12	1-14	1 3/8-12	1-14	1 3/8-12	1 3/8-12	1 1/2-12	1 3/8-12	1 1/2-12	
L	¾	¾	¾	¾	¾	1 1/4	1 1/4	1 1/4	1 1/4	1 1/4	1 1/4	1 1/2	1 1/2	1 7/16	1 7/16	
LB	4	4	4	4 1/8	4 1/8	4 7/8	4 7/8	4 7/8	4 7/8	5 1/8	5 1/8	5 1/8	5 1/8	5 1/4	5 1/4	
LD	4 7/8	4 7/8	4 7/8	5	5	6	6	6	6	6 1/4	6 1/4	5 5/8	5 5/8	5 3/4	5 3/4	
LR	9/16	9/16	9/16	9/16	9/16	1	1	1	1	1	1	1 1/4	1 1/4	1 1/4	1 1/4	
M	1/2	1/2	1/2	1/2	1/2	¾	¾	¾	¾	¾	¾	1	1	1	1	
MM	5/8	5/8	1	5/8	1	1	1 3/8	1	1 3/8	1	1 3/8	1 3/8	1 1/2	1 3/8	1 1/2	
MR	1/2	1/2	1/2	1/2	1/2	7/8	7/8	1 5/16	1 5/16	1 5/16	1 5/16	1 5/16	1 5/16	1 5/16	1 5/16	
NT	1/4-20	5/16-18	5/16-18	3/8-16	3/8-16	1/2-13	1/2-13	1/2-13	1/2-13	5/8-11	5/8-11	¾-10	¾-10	¾-10	¾-10	
P	2 1/4	2 1/4	2 1/4	2 3/8	2 3/8	2 5/8	2 5/8	2 5/8	2 5/8	2 7/8	2 7/8	3 1/8	3 1/8	3 1/4	3 1/4	
R	1.43	1.84	1.84	2.19	2.19	2.76	2.76	3.32	3.32	4.10	4.10	4.88	4.88	6.44	6.44	
S	1 1/4	1 3/4	1 3/4	2 1/4	2 1/4	2 3/4	2 3/4	3 1/2	3 1/2	4 1/4	4 1/4	—	—	—	—	
SA	6	6	6	6 1/8	6 1/8	7 3/8	7 3/8	7 3/8	7 3/8	7 7/8	7 7/8	—	—	—	—	



# SERIES I CYLINDER DIMENSIONS

BORE	1½	2		2½		3¼		4		5		6		8	
ROD DIA.	5/8	5/8	1	5/8	1	1	1¾	1	1¾	1	1¾	1¾	1½	1¾	1½
SB	7/16	7/16	7/16	7/16	7/16	9/16	9/16	9/16	9/16	13/16	13/16	13/16	13/16	13/16	13/16
SE	5½	5¾	5¾	6¼	6¼	6⅝	6⅝	6⅞	6⅞	7¼	7¼	—	—	—	—
SN	2¼	2¼	2¼	2⅜	2⅜	2⅝	2⅝	2⅝	2⅝	2⅞	2⅞	3⅞	3⅞	3¼	3¼
SS	2⅞	2⅞	2⅞	3	3	3¼	3¼	3¼	3¼	3⅞	3⅞	3⅝	3⅝	3¾	3¾
ST	9/16	5/8	5/8	½	½	¾	¾	¾	¾	1	1	1	1	1	1
FSU	5/8	¾	¾	¾	¾	⅞	⅞	5/8	5/8	11/16	11/16	1¾	1¾	1¾	1¾
RSU	5/8	5/8	5/8	5/8	5/8	⅞	⅞	5/8	5/8	11/16	11/16	1¼	1¼	1¼	1¼
SW	¾	¾	¾	¾	¾	½	½	½	½	11/16	11/16	¾	¾	¾	¾
TD	1	1	1	1	1	1	1	1	1	1	1	1¾	1¾	1¾	1¾
TE	—	—	—	—	—	—	—	—	—	—	—	—	—	7.57	7.57
TF	2¾	3¾	3¾	3⅞	3⅞	411/16	411/16	57/16	57/16	6⅝	6⅝	7⅝	7⅝	—	—
TK	¾	9/16	9/16	9/16	9/16	¾	¾	1	1	1	1	¾	¾	1⅞	1⅞
TL	15/16	15/16	15/16	15/16	15/16	15/16	15/16	15/16	15/16	15/16	15/16	1¾	1¾	1¾	1¾
TM	2½	2⅞	2⅞	3⅜	3⅜	4½	4½	5½	5½	6½	6½	8½	8½	—	—
TN	5/8	⅞	⅞	1¼	1¼	1½	1½	21/16	21/16	211/16	211/16	3¼	3¼	4½	4½
TS	2¾	3¼	3¼	3¾	3¾	4¾	4¾	5½	5½	6⅞	6⅞	7⅞	7⅞	9⅞	9⅞
UF	3⅜	4⅞	4⅞	4⅝	4⅝	5½	5½	6¼	6¼	7⅝	7⅝	8⅝	8⅝	—	—
UM	4¾	4¾	4¾	5¼	5¼	6⅜	6⅜	7⅜	7⅜	8⅜	8⅜	11¼	11¼	—	—
US	3½	4	4	4½	4½	5¾	5¾	6½	6½	8¼	8¼	9¼	9¼	11¼	11¼
UT	3⅞	4⅜	4⅜	4⅞	4⅞	5⅝	5⅝	6⅜	6⅜	7⅜	7⅜	9¼	9¼	11¼	11¼
UV	2½	2⅞	2⅞	3⅜	3⅜	4½	4½	5½	5½	6½	6½	8½	8½	—	—
UW	1/16	1/16	1/16	1/16	1/16	1/16	1/16	1/16	1/16	1/16	1/16	1/8	1/8	1/8	1/8
V	¼	¼	½	¼	½	¼	¾	¼	¾	¼	¾	¼	¼	¼	¼
W	5/8	5/8	1	5/8	1	¾	1	¾	1	¾	1	19/16	113/16	19/16	113/16
XA	5⅝	5⅝	6	5¾	6⅞	6⅞	7⅞	6⅞	7⅞	7¼	7½	—	—	—	—
XC	5¾	5¾	5¾	5½	5⅞	6⅞	7⅞	6⅞	7⅞	7⅞	7⅞	83/16	87/16	8¼	8½
XD	5¾	5¾	6⅞	5⅞	6¼	7½	7¾	7½	7¾	7¾	8	815/16	93/16	91/16	95/16
XE	5⅜	59/16	515/16	513/16	63/16	6½	6¾	6⅝	6⅞	615/16	73/16	—	—	—	—
XG	1¾	1¾	2⅞	1¾	2⅞	2¼	2½	2¼	2½	2¼	2½	2⅝	2⅞	2⅝	2⅞
XJ	4⅞	4⅞	4½	4¼	4⅝	5	5¼	5	5¼	5¼	5½	515/16	63/16	61/16	65/16
XS	1¾	1¾	1¾	1¾	1¾	1⅞	2⅞	1⅞	2⅞	21/16	25/16	25/16	29/16	25/16	29/16
XT	115/16	115/16	25/16	115/16	25/16	27/16	211/16	27/16	211/16	27/16	211/16	213/16	31/16	213/16	31/16
Y	115/16	115/16	25/16	115/16	25/16	27/16	211/16	27/16	211/16	27/16	211/16	213/16	31/16	213/16	31/16
ZA	6⅞	6⅞	6½	6¼	6⅝	7⅞	7⅝	7⅞	7⅝	7⅞	8⅞	—	—	—	—
ZB	425/32	413/16	53/16	415/16	55/16	527/32	63/32	527/32	63/32	63/16	67/16	7	7¼	73/16	77/16
ZE	523/32	57/8	6¼	6⅞	6½	6⅞	7⅞	7	7¼	77/16	711/16	—	—	—	—
ZF	5	5	5⅜	5⅞	5½	6¼	6½	6¼	6½	6½	6¾	77/16	711/16	—	—
ZJ	4⅝	4⅝	5	4¾	5⅞	5⅝	5⅞	5⅝	5⅞	5⅞	6⅞	611/16	615/16	613/16	71/16
ZL	5½	5½	5⅞	5⅝	6	6¾	7	6¾	7	7	7¼	73/16	77/16	75/16	79/16
ZM	6⅞	6⅞	6⅞	6¼	7	7½	8	7½	8	7¾	8¼	8¾	9¼	8⅞	9⅝
ZZ	¾	½	½	½	½	5/8	5/8	5/8	5/8	5/8	5/8	—	—	—	—



# NFPA MOUNTING STYLES (1 1/2" - 5" BORE)

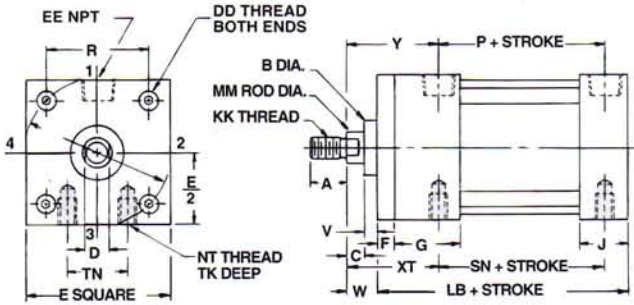

**SIDE TAPPED (MS4)**

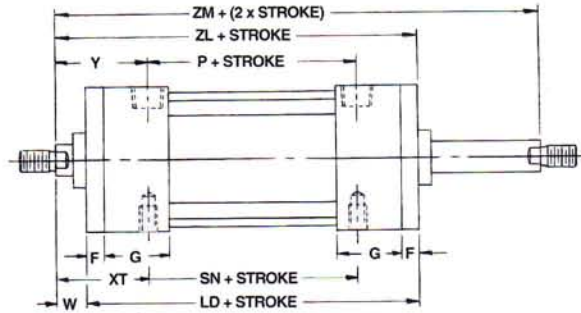

**DOUBLE ROD END SIDE TAPPED (MDMS4)**

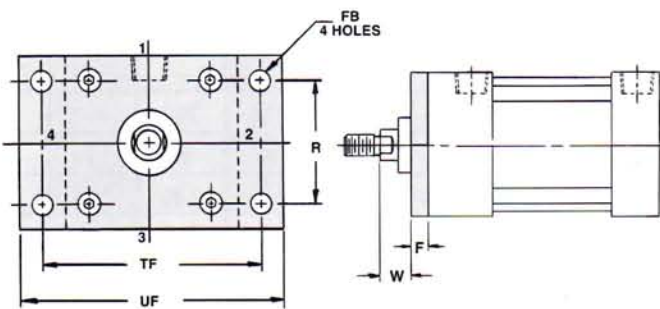

**HEAD RECTANGULAR FLANGE (MF1)**

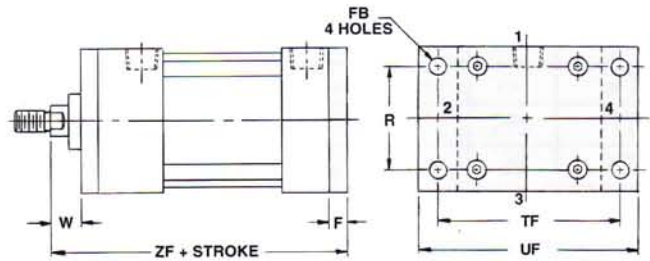

**CAP RECTANGULAR FLANGE (MF2)**

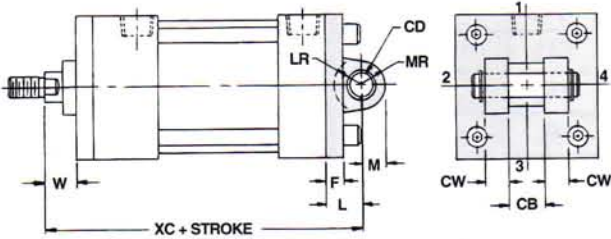

**CAP CLEVIS DETACHABLE (MP1)**

Furnished with pin & snaps  
Cast iron MP1 available

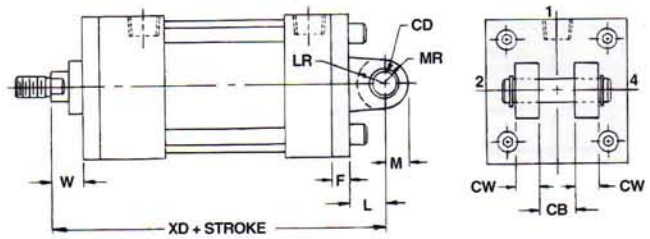

**CAP CLEVIS DETACHABLE (MP2)**

Furnished with pin & snaps  
Cast iron MP2 available

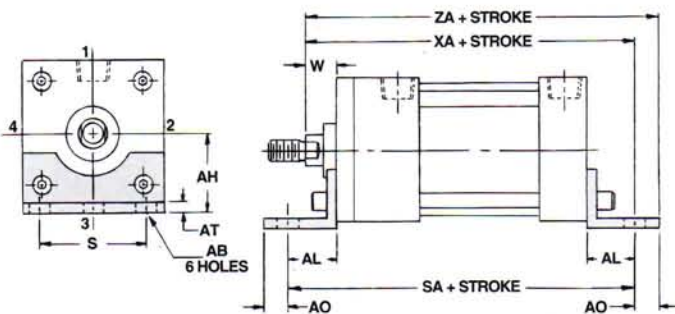

**SIDE END ANGLES (MS1)**

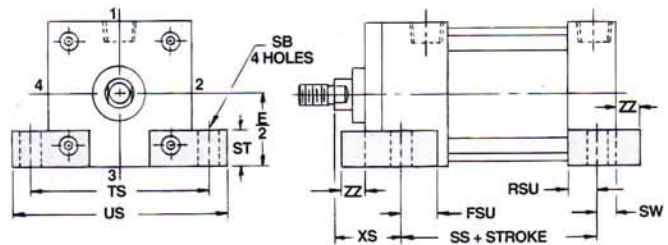

**SIDE LUGS (MS2)**



# NFPA MOUNTING STYLES (1 1/2" - 5" BORE)

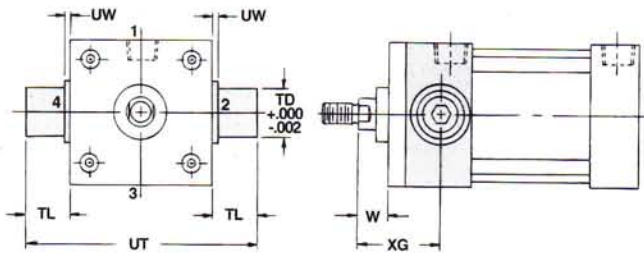

**HEAD TRUNNION (MT1)**

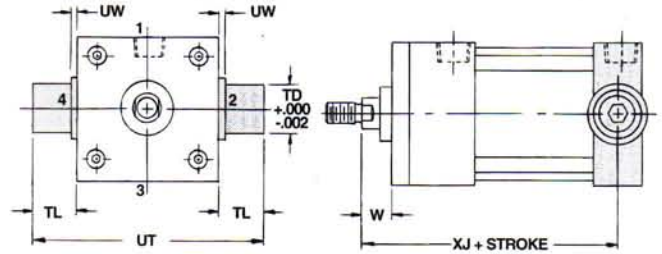

**CAP TRUNNION (MT2)**

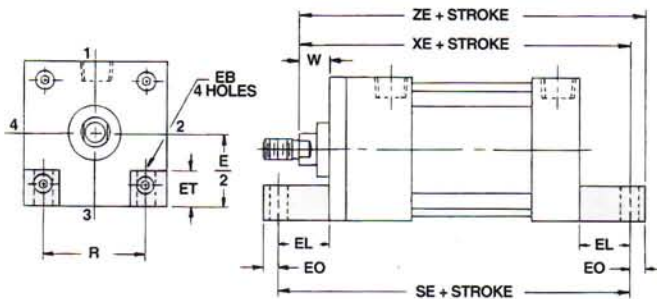

**SIDE END LUGS (MS7)**

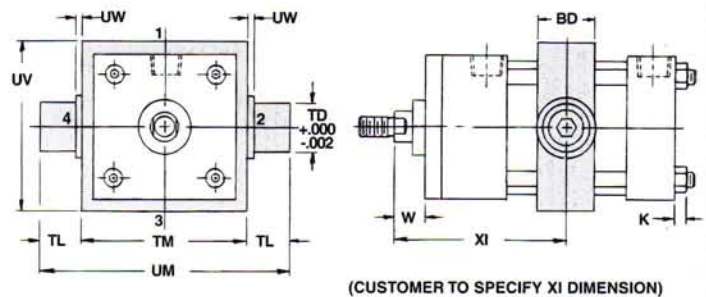

**INTERMEDIATE TRUNNION (MT4)**

**BOTH ENDS TIE RODS EXTENDED (MX1)**

(ILLUSTRATED)

**CAP TIE RODS EXTENDED (MX2)**

**HEAD TIE RODS EXTENDED (MX3)**

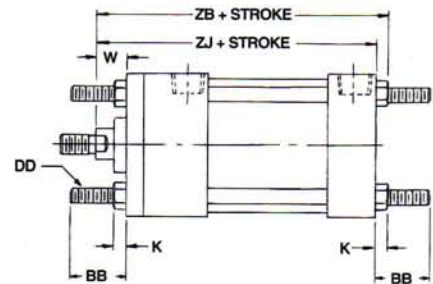
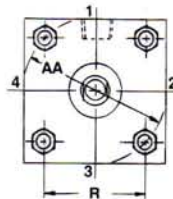

## ROD END STYLES (For other optional rod ends, specify thread, length or depth)

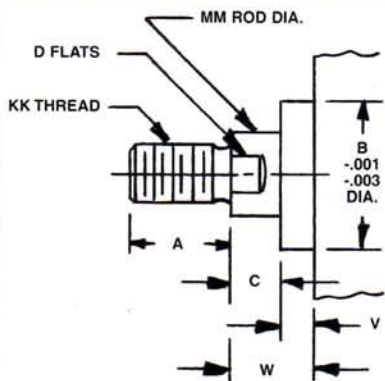

**Style #2 Standard Small Male Thread**

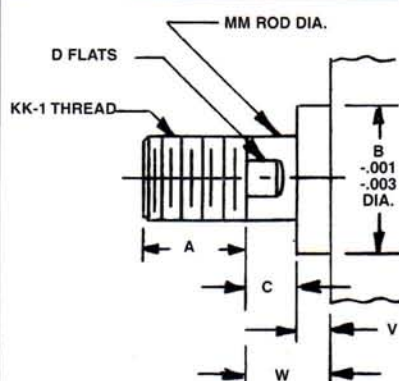

**Style #1 Optional Full Male Thread**

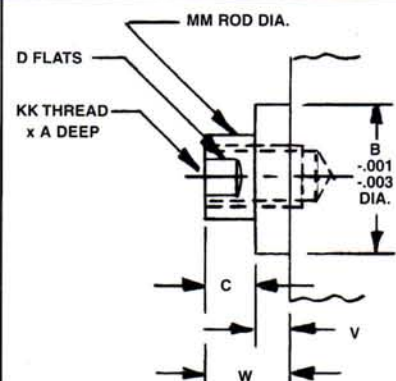

**Style #3 Optional Female Thread**

# NFPA MOUNTING STYLES (6" - 8" BORE)

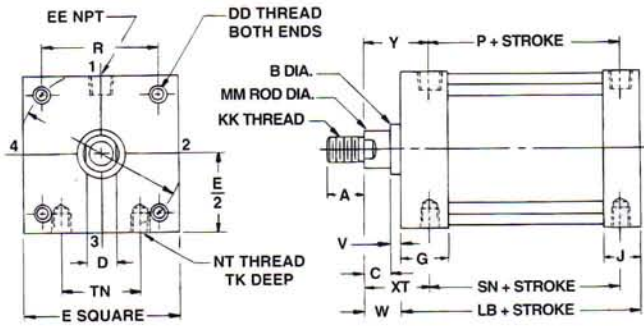

**SIDE TAPPED (MS4)**

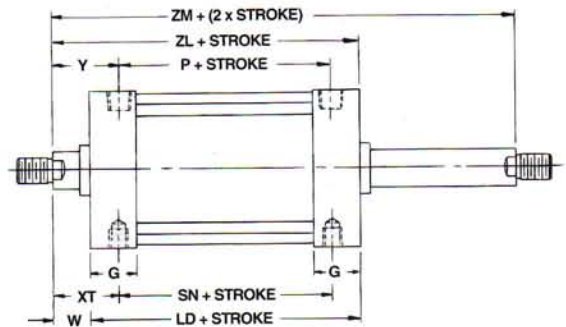

**DOUBLE ROD END SIDE TAPPED (MDMS4)**

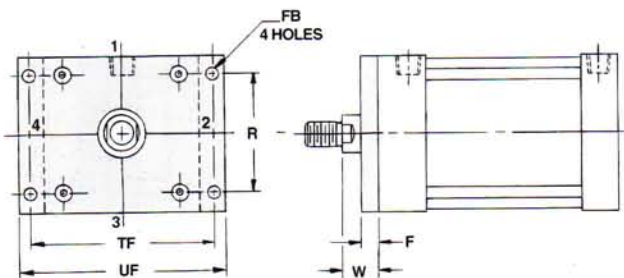

**HEAD RECTANGULAR FLANGE (MF1)**  
6" bore only

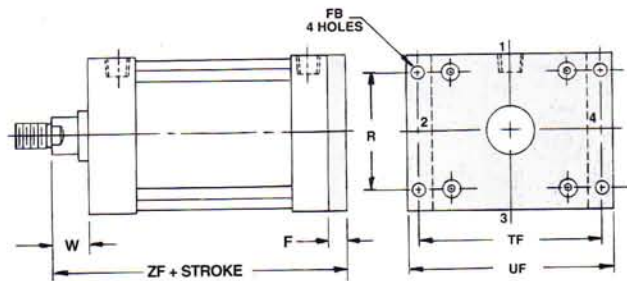

**CAP RECTANGULAR FLANGE (MF2)**  
6" bore only

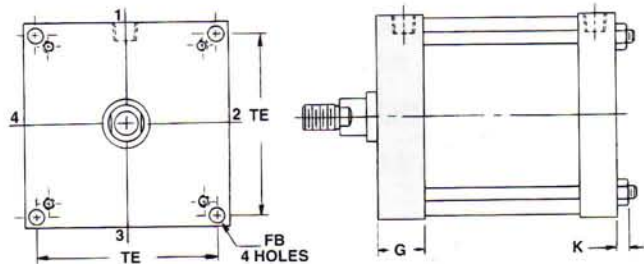

**HEAD SQUARE FLANGE (ME3)...**  
8" bore only

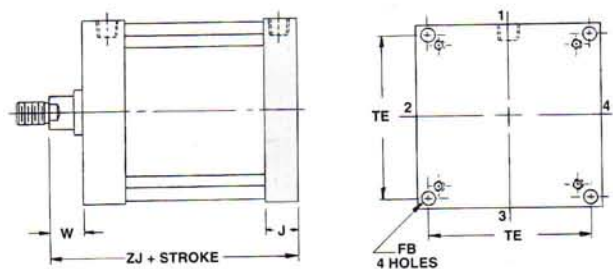

**CAP SQUARE FLANGE (ME4)**  
8" bore only

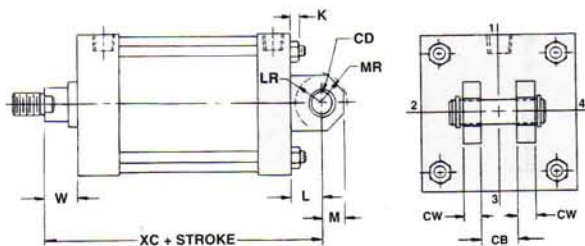

**CAP CLEVIS WELDED (MP1)**  
Furnished with pin & snaps

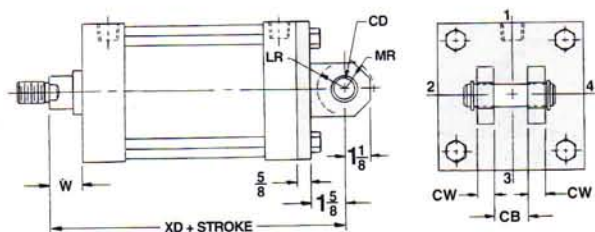

**CAP CLEVIS DETACHABLE (MP2)**  
Furnished with pin & snaps  
| 8" cap must be tapped to accept MP2  
Base plate is 6-7/16" square



# NFPA MOUNTING STYLES (6" - 8" BORE)

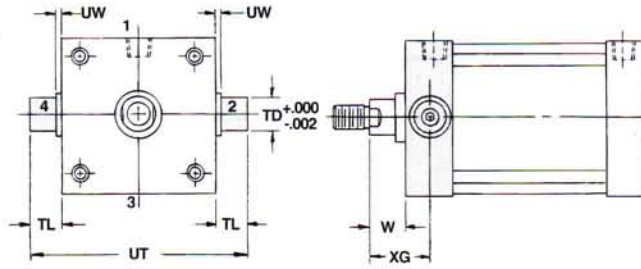

**HEAD TRUNNION (MT1)**

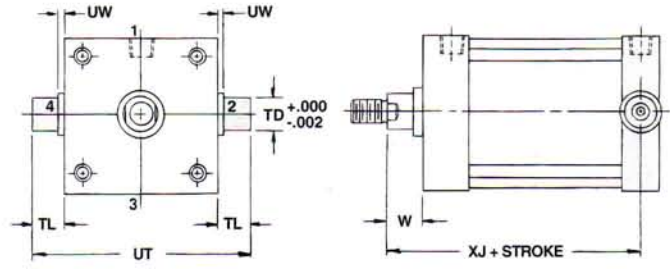

**CAP TRUNNION (MT2)**

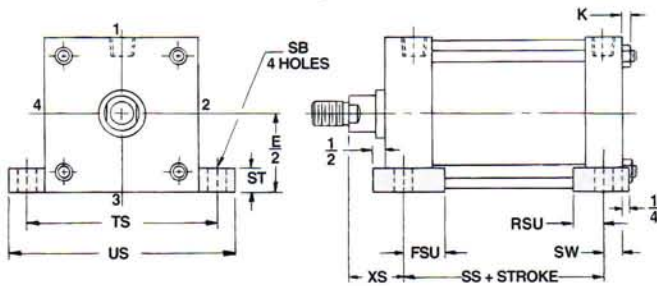

**SIDE LUGS WELDED (MS2)**

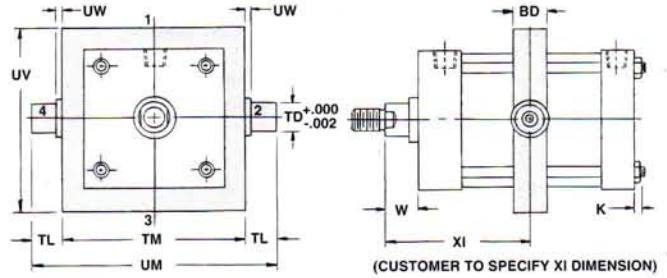

**INTERMEDIATE TRUNNION (MT4)**  
6" bore only

**BOTH ENDS TIE RODS EXTENDED (MX1)**  
(ILLUSTRATED)

**CAP TIE RODS EXTENDED (MX2)**

**HEAD TIE RODS EXTENDED (MX3)**

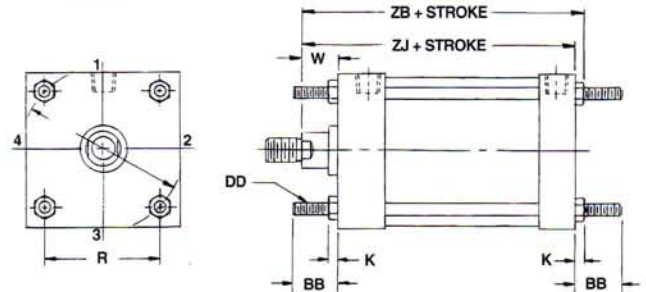

## ROD END STYLES (For other optional rod ends, specify thread, length or depth)

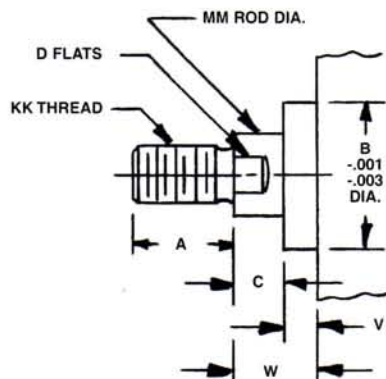

**Style #2 Standard Small Male Thread**

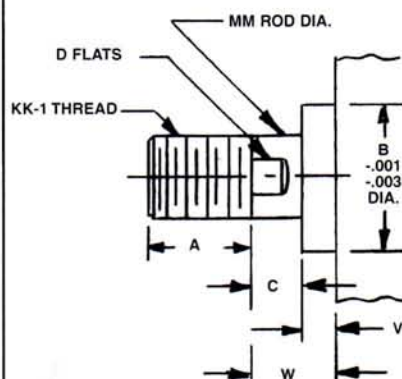

**Style #1 Optional Full Male Thread**

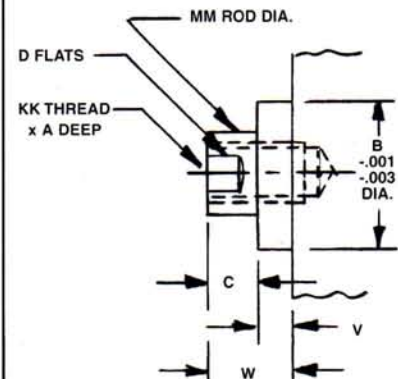

**Style #3 Optional Female Thread**

# SERIES I ACCESSORIES

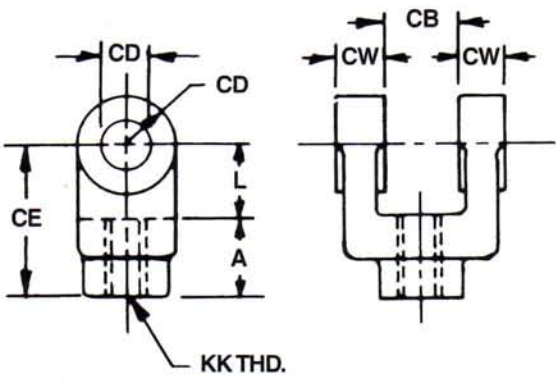

## ROD CLEVIS

PART NUMBER	THD. KK	A	L	CB	CD	CE	CW
RC-437	7/16-20	3/4	3/4	3/4	1/2	1 1/2	1/2
RC-750	3/4-16	1 1/8	1 1/4	1 1/4	3/4	2 3/8	5/8
RC-100	1-14	1 5/8	1 1/2	1 1/2	1	3 1/8	3/4
*BRC-125	1 1/4-12	1 5/8	1	1	1	3	1/2

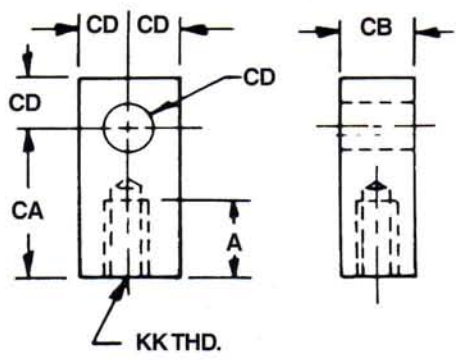

## ROD EYE

PART NUMBER	THD. KK	A	CA	CB	CD
RE-437	7/16-20	3/4	1 1/2	3/4	1/2
RE-750	3/4-16	1 1/8	2 1/16	1 1/4	3/4
RE-100	1-14	1 5/8	2 13/16	1 1/2	1
*BRE-125	1 1/4-12	1 5/8	3	2	1

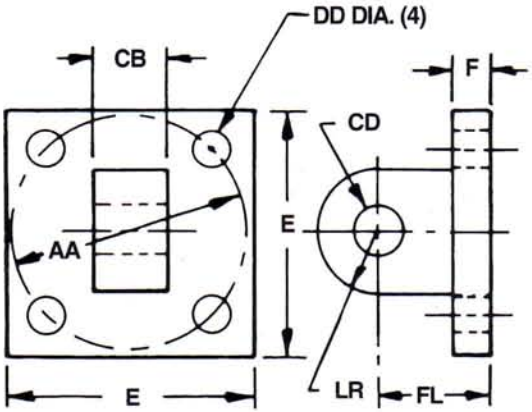

## EYE BRACKET

PART NUMBER	BORE SIZE	AA	E	F	CB	CD	DD	FL	LR
EM-500	1 1/2, 2 & 2 1/2	2.31	2 1/2	3/8	3/4	1/2	3/8	1 1/8	1/2
EM-750	3 1/4, 4 & 5	3.61	3 1/2	5/8	1 1/4	3/4	1/2	1 7/8	3/4
*BEM-100	6 & 8	6.89	6 1/2	5/8	1 1/2	1	1/2	2 1/4	1 1/4

Eye bracket interfaces with MP1 & MP2 clevis mount.  
To use with rod clevis, check CB & CD dimensions.

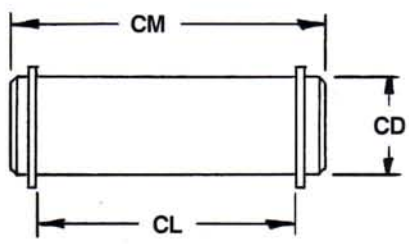

## PIVOT PIN & SNAPS

PART NUMBER	CD	CL	CM	W/ROD CLEVIS	W/ROD EYE
P-500	1/2	1 25/32	2	RC-437	RE-437
P-750	3/4	2 11/16	3 1/16	RC-750	RE-750
P-100	1	3 1/16	3 5/16	RC-100	RE-100
*BP-1100	1	2 1/16	2 5/16	BRC-125	—

\* From Series B & J



# MULTIPLE POSITION CYLINDERS

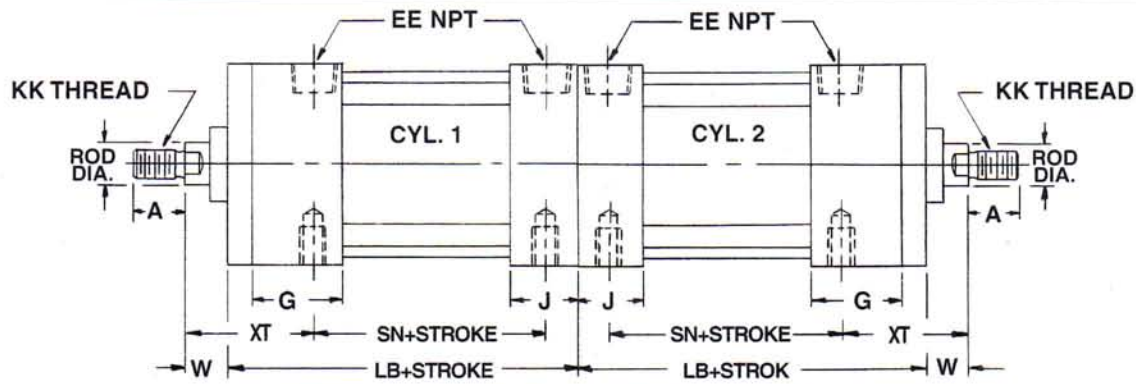

**SERIES I 1 1/2" - 5" BORE MULTIPLE POSITION  
TANDEM BACK TO BACK**

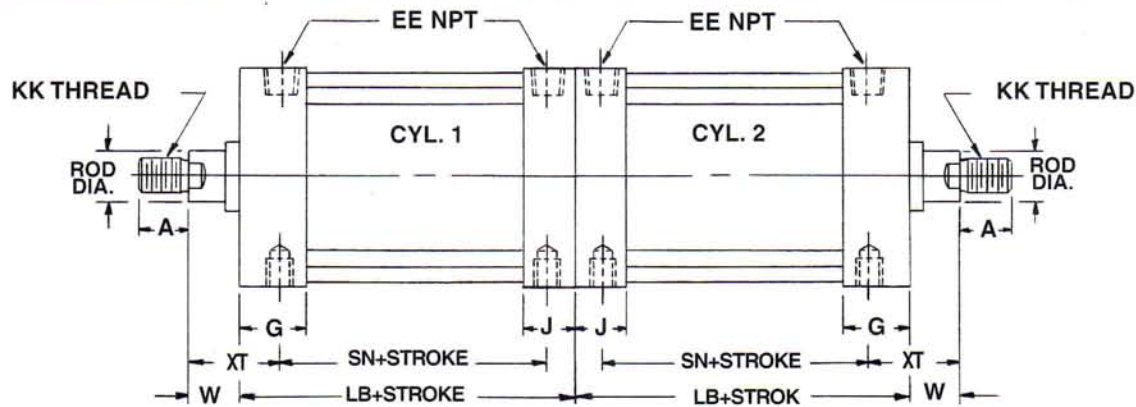

**SERIES I 6" - 8" BORE MULTIPLE POSITION      TANDEM BACK TO BACK**

CONSULT FACTORY FOR ORDERING INSTRUCTIONS

## SERIES I CYLINDER DIMENSIONS

BORE	ROD DIA.	A	G	J	W	EE NPT	LB	KK	SN	XT
1 1/2	5/8	3/4	1 3/8	1	5/8	3/8	4	7/16 - 20	2 1/4	1 15/16
2	5/8	3/4	1 3/8	1	5/8	3/8	4	7/16 - 20	2 1/4	1 15/16
	1	1 1/8			1					
2 1/2	5/8	3/4	1 3/8	1	5/8	3/8	4 1/8	7/16 - 20	2 3/8	1 15/16
	1	1 1/8			1					
3 1/4	1	1 1/8	1 5/8	1 1/4	3/4	1/2	4 7/8	3/4 - 16	2 5/8	2 7/16
	1 3/8	1 5/8			1					
4	1	1 1/8	1 5/8	1 1/4	3/4	1/2	4 7/8	3/4 - 16	2 5/8	2 7/16
	1 3/8	1 5/8			1					
5	1	1 1/8	1 5/8	1 1/4	3/4	1/2	5 1/8	3/4 - 16	2 7/8	2 7/16
	1 3/8	1 5/8			1					
6	1 3/8	1 5/8	2	1 1/2	1 9/16	3/4	5 1/8	1 - 14	3 1/8	2 13/16
	1 1/2	2			1 13/16					
8	1 3/8	1 5/8	2	1 1/2	1 9/16	3/4	5 1/4	1 - 14	3 1/4	2 13/16
	1 1/2	2			1 13/16					

# MULTIPLE POSITION CYLINDERS

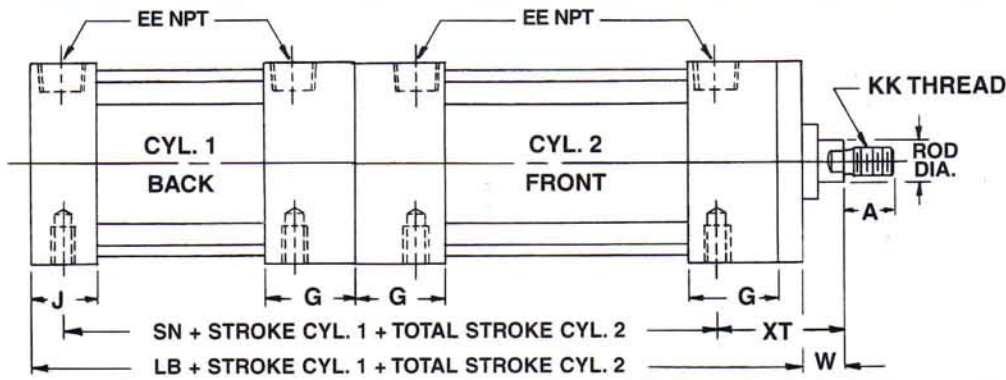

**SERIES I 1 1/2" - 5" BORE MULTIPLE POSITION TANDEM FRONT TO BACK**  
 CONSULT FACTORY FOR ONE CENTER HEAD DESIGN

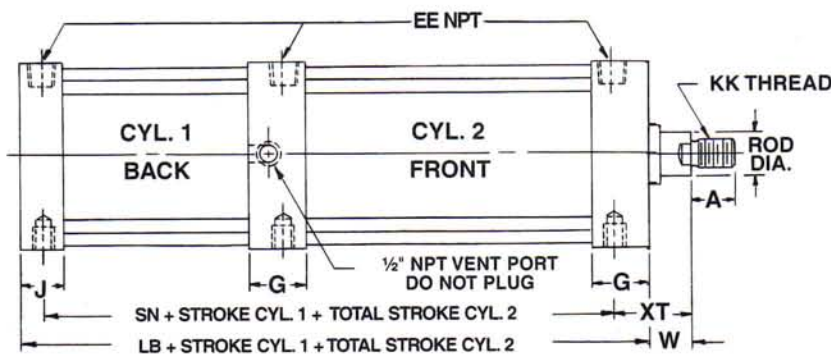

**SERIES I 6" - 8" BORE MULTIPLE POSITION TANDEM FRONT TO BACK**  
 CONSULT FACTORY FOR ORDERING INSTRUCTIONS

## SERIES I CYLINDER DIMENSIONS

BORE	ROD DIA.	A	G	J	W	EE NPT	LB	KK	SN	XT
1 1/2	5/8	3/4	1 3/8	1	5/8	3/8	8	7/16 - 20	6 1/4	1 15/16
2	5/8	3/4	1 3/8	1	5/8	3/8	8	7/16 - 20	6 1/4	1 15/16
	1	1 1/8			1			3/4 - 16		2 5/16
2 1/2	5/8	3/4	1 3/8	1	5/8	3/8	8 1/4	7/16 - 20	6 1/2	1 15/16
	1	1 1/8			1			3/4 - 16		2 5/16
3 1/4	1	1 1/8	1 5/8	1 1/4	3/4	1/2	9 1/2	3/4 - 16	7 1/4	2 7/16
	1 3/8	1 5/8			1			1 - 14		2 11/16
4	1	1 1/8	1 5/8	1 1/4	3/4	1/2	9 1/2	3/4 - 16	7 1/4	2 7/16
	1 3/8	1 5/8			1			1 - 14		2 11/16
5	1	1 1/8	1 5/8	1 1/4	3/4	1/2	10	3/4 - 16	7 3/4	2 7/16
	1 3/8	1 5/8			1			1 - 14		2 11/16
6	1 3/8	1 5/8	2	1 1/2	1 9/16	3/4	9 3/4	1 - 14	7 3/4	2 13/16
	1 1/2	2			1 13/16			1 1/4 - 12		3 1/16
8	1 3/8	1 5/8	2	1 1/2	1 9/16	3/4	10	1 - 14	8	2 13/16
	1 1/2	2			1 13/16			1 1/4 - 12		3 1/16



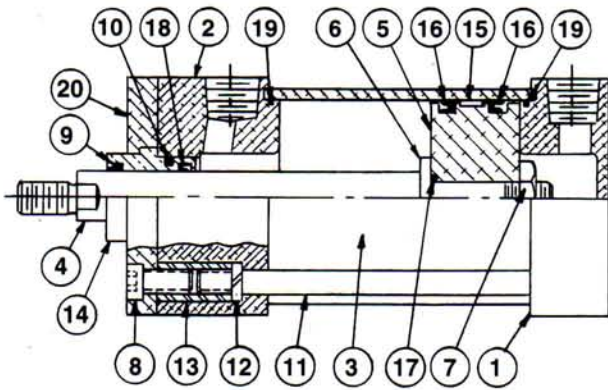

**SERIES I NON-CUSHION**

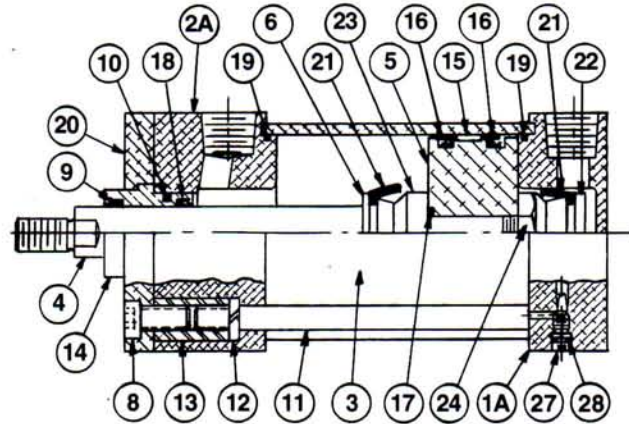

**SERIES I DOUBLE CUSHION**

**PARTS LIST**

P/N	DESCRIPTION	QTY.
1	REAR CAP	1
1A	REAR CAP CUSHIONED (WITH P/N 27 & 28)	1
2	FRONT HEAD	1
2A	FRONT HEAD CUSHIONED (WITH P/N 27 & 28)	1
3	CYLINDER TUBE	1
4	PISTON ROD	1
5	PISTON	1
6	SUPPORT WASHER	1*
7	PISTON NUT	1
8	RETAINING PLATE BOLT	4
9	ROD WIPER	1
10	ROD BUSHING "O" RING	1
11	TIE ROD	4
12	TIE ROD LOCKWASHER	4
13	TIE ROD NUT	4
14	ROD BUSHING	1
15	PISTON BEARING STRIP	1
16	PISTON SEAL	2
17	PISTON ROD "O" RING	1
18	ROD SEAL (STANDARD)	1
18PP	ROD SEAL (HYDRAULIC)	1
19	TUBE SEAL "O" RING	2
20	RETAINING PLATE	1
21	CUSHION CUP	1†
22	REAR CUSHION RETAINING BOLT	1
23	FRONT CUSHION SPACER	1
24	REAR CUSHION SPACER NUT	1
27	CUSHION SCREW	1†
28	CUSHION SCREW "O" RING	1†

† Per cushion

\* Not used on 1 1/2" - 5" bore with oversize rod.

**REPAIR KITS**

Repair kits containing all wearable replacement parts are available.

Please specify cylinder bore, rod diameter, single or double ended, type of cushion, air or hydraulic operated and any options which affect repair kit.

The 1 1/2" bore magno piston cylinder requires a special piston bearing strip. Please specify MAGNO when ordering this bore repair kit.

**STANDARD REPAIR KIT CONTAINS:**

P/N 9,10, 14, 15, 16, 17, 18 &19.

**CUSHION REPAIR KIT CONTAINS:**

Standard repair kit plus P/N 21 & 28.

**NOTE:** Cylinder design and cushion design for 1 6" & 8" bore are similar to Series J.

When ordering parts please specify cylinder bore, rod diameter, type of cushion and any options.



# Selecting Cylinder Bore Size

When selecting a cylinder bore size for your application, first determine the maximum push or pull force required. Next, add at least 10% to the push/pull force or the working pressure to compensate for pressure drop in the

line and friction in the cylinder. This 10% figure is adequate for normal applications. Finally, knowing the working pressure available, select your cylinder bore size from the selection chart.

CYL. BORE DIA.	PISTON ROD DIA.	CYL. WORK ACTION	WORK AREA SQ. IN.	AIR PRESSURE P.S.I.							FLUID REQUIRED PER IN. OF STROKE	
				60	80	90	100	150	200	250	GALLON	CU. FT.
1½	¾	Push	1.767	106	141	159	177	265	353	442	.00765	.00102
		Pull	1.460	88	117	131	146	219	292	365	.00632	.00084
2	1	Push	3.141	188	251	282	314	471	628	785	.01360	.00182
		Pull	2.835	170	227	255	284	425	567	709	.01227	.00164
2½	1	Push	4.908	294	392	441	490	736	981	1227	.02125	.00284
		Pull	4.602	276	368	414	460	690	920	1151	.01992	.00266
3¼	1½	Push	8.296	498	664	747	830	1245	1660	2074	.03590	.00480
		Pull	7.511	451	601	676	751	1127	1502	1878	.03250	.00435
4	1½	Push	11.081	665	886	997	1108	1662	2216	2770	.04800	.00641
		Pull	11.081	665	886	997	1108	1662	2216	2770	.04800	.00641
5	1½	Push	19.635	1178	1570	1767	1963	2945	3927	4908	.08500	.01136
		Pull	18.850	1131	1508	1697	1885	2828	3770	4713	.08160	.01091
6	1½	Push	28.274	1696	2262	2544	2827	4241	5654	7068	.12240	.01636
		Pull	26.789	1607	2144	2411	2679	4018	5358	6697	.11600	.01550
8	1½	Push	50.265	3015	4021	4523	5026	7539	10053	12566	.21760	.02915
		Pull	48.780	2927	3902	4390	4878	7317	9756	12195	.21120	.02823
8	1½	Push	48.498	2909	3879	4364	4849	7274	9699	12124	.20990	.02810
		Pull	48.498	2909	3879	4364	4849	7274	9699	12124	.20990	.02810

# Selecting Cylinder Rod Diameter

**Standard Rods** - Standard rods can usually be selected when a cylinder is used for a pull or tension application. In some applications where long stroke cylinders are used for pull or tension, oversize rods may be required to eliminate rod sag.

**Oversize Rods** - Oversize rods are often required when a cylinder is used in a thrust or push application. In these applications, the designer must treat the piston rod as a column in compression and specify a rod large enough to prevent rod buckling.

## MOUNTING TYPES

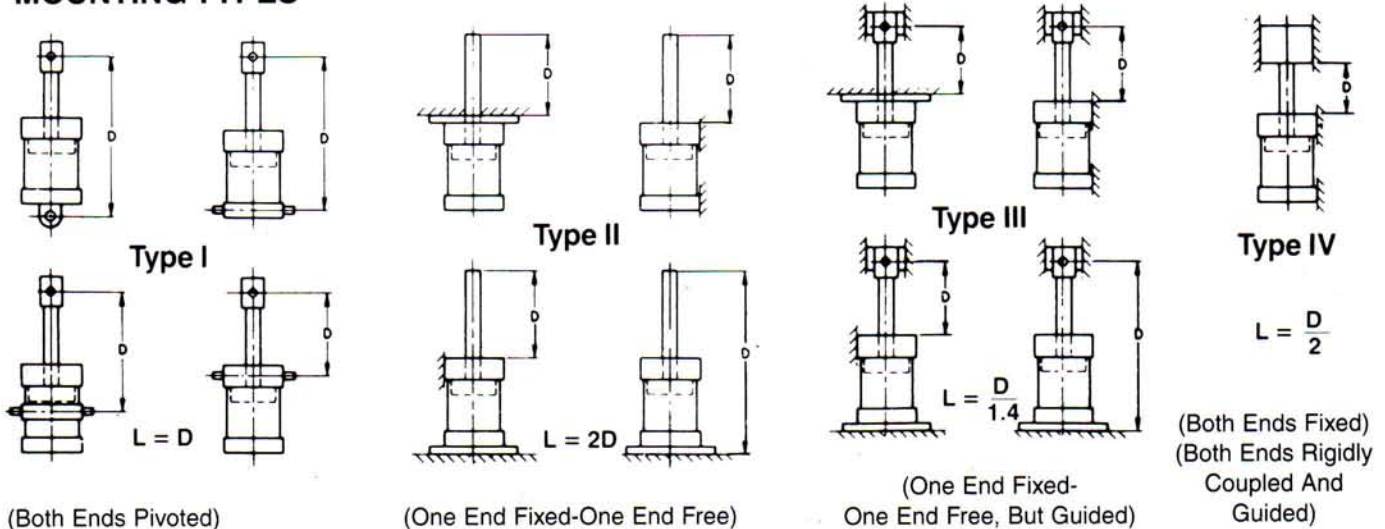



# Rod Diameter Selection

To determine the correct rod for your application, follow the steps listed below:

- Determine the load or maximum thrust required.
- Classify your application as one of the mounting types illustrated.
- Determine stop tube length-see stop tube instructions.
- Determine the value of "L" for your application with the rod fully extended. (See dimensional chart below.)
- By referring to chart, select a thrust figure from the left-hand column, equal to or greater than the thrust of your application.
- Scan to the right of the thrust figure selected until an "L" value is equal to or greater than the "L" value determined above.
- Follow the "L" value column to the top of the chart to find the recommended rod diameter.
- In some cases, the recommended rod diameter may be larger than is available in the bore size selected. In this case, a larger bore size should be selected.

Thrust Load in Lbs.	VALUES OF "L" IN INCHES PISTON ROD DIAMETERS			
	5/8	1	1 1/8	1 1/2
100	75	191		
150	61	156		
200	53	135	255	
250	47	121	228	
300	43	110	208	250
350	40	102	193	232
400	38	96	180	217
450	35	90	170	205
500	34	86	161	194
600	31	79	147	177
700	28	72	137	164
800	27	68	128	154
900	25	64	120	145
1000	24	61	114	138
1200	22	55	104	125
1400	20	51	97	116

Thrust Load in Lbs.	VALUES OF "L" IN INCHES PISTON ROD DIAMETERS			
	5/8	1	1 1/8	1 1/2
1600	19	48	90	108
1800	18	45	85	102
2000	17	43	81	97
2200	16	41	77	92
2600	15	38	71	85
3000	14	35	66	79
3500	13	32	61	73
4000	12	30	57	68
5000	11	27	50	61
6000	10	25	47	56
7000	9	23	43	52
8000	8	22	41	49
9000		20	38	45
10000		19	36	43
12500		17	32	38

## Stop Tubes

A stop tube is a spacer placed between the piston and the rod end head to reduce bearing loads. The reduction in bearing load is done by increasing the distance between bearing surfaces.

Stop tubes are recommended for mounting types I and II any time the "L" dimension of that application exceeds 40".

Stop tubes are normally not required with mounting types III and IV but the designer should use his own discretion to keep bearing loads to a minimum. Stop tubes should be specified at a rate of 1" for every 10", or fraction thereof, over an "L" dimension of 40".

Adjust "L" dimension by adding stop tube length when using "L" to determine rod diameter.

Note: Increasing rod diameter to reduce bearing load is not recommended. Stop tubes are more effective and generally more economical.

# CYLINDER OPTIONS

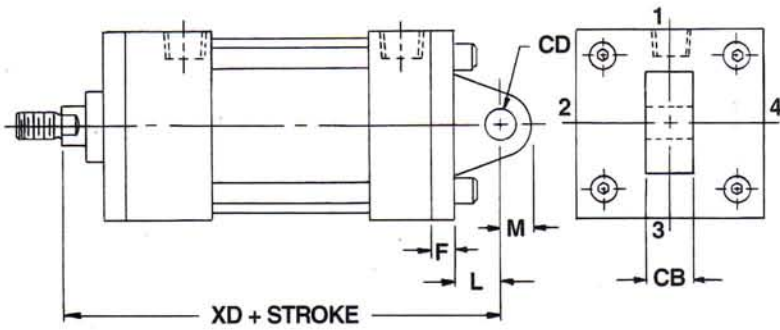

**CAST IRON CAP EYE MOUNT  
DETACHABLE (MP4)**

BORE	ROD DIA.	F	L	M	CB	CD	XD
1½	5/8	3/8	3/4	5/8	3/4	1/2	5¼
2	5/8	3/8	3/4	5/8	3/4	1/2	5¾
	1						6½
2½	5/8	3/8	3/4	5/8	3/4	1/2	5¾
	1						6¼
3¼	1	5/8	1¼	7/8	1¼	3/4	7½
	1¾						7¾
4	1	5/8	1¼	7/8	1¼	3/4	7½
	1¾						7¾

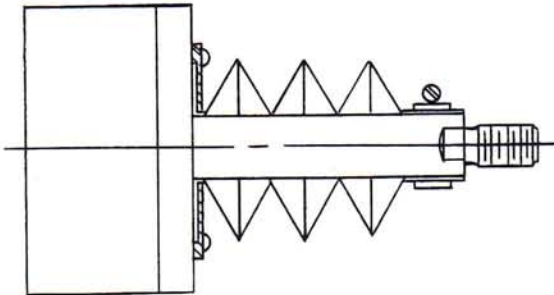

Rod boots are used for added protection from environmental conditions. Material is Neoprene/Nylon .050-.060 gauge with an operating temperature of 0°F to 200°F.

NOTE: Rod extension increases 1" in length for every 3" of stroke. Maximum stroke is 24".

Not available on 1 1/2" bore, Model B120, or Series R cylinders.

Design changes for 1 3/8" & 1 1/2" rod diameter.

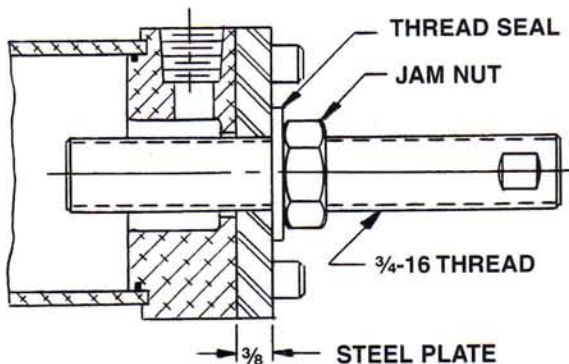

## ADJUSTABLE STROKE

The adjustment is suitable for infrequent adjustments in the reduction of stroke length in the retracted position.

Length of adjustment must be specified when ordering.

Rear cap cushion is not available.

Steel plate may not be the same square size as rear cap on larger bore cylinders.



# CYLINDER OPTIONS

## STOP TUBE

A stop tube increases the distance between the rod bushing and piston to reduce bearing loads when the piston rod is fully extended. See page 17 to determine stop tube length.

When ordering please specify nominal stroke, stop tube length and effective stroke.

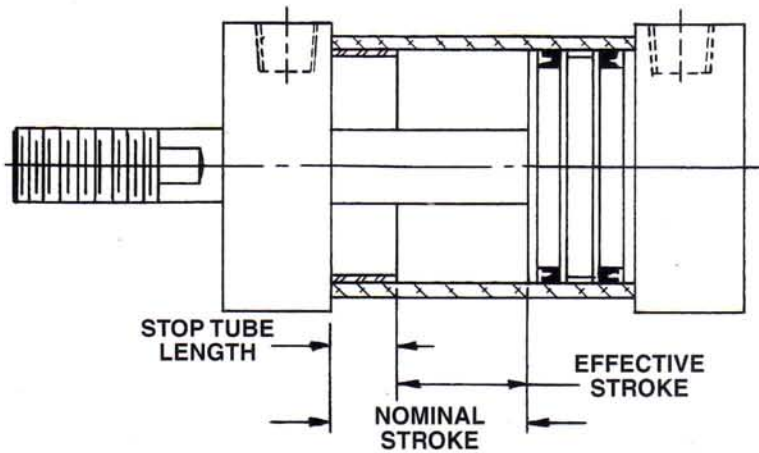

**SERIES B, J OR R**  
(SERIES B ILLUSTRATED)

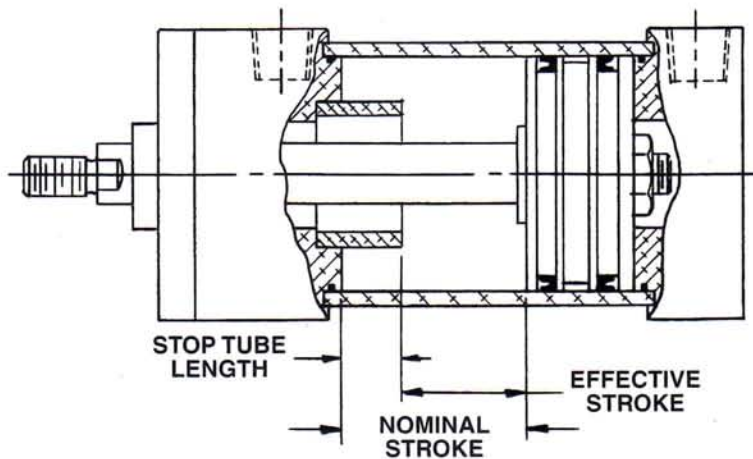

**SERIES I**  
(SERIES I 1 1/2" - 5" BORE ILLUSTRATED)  
SERIES I 6" - 8" BORE MAY VARY

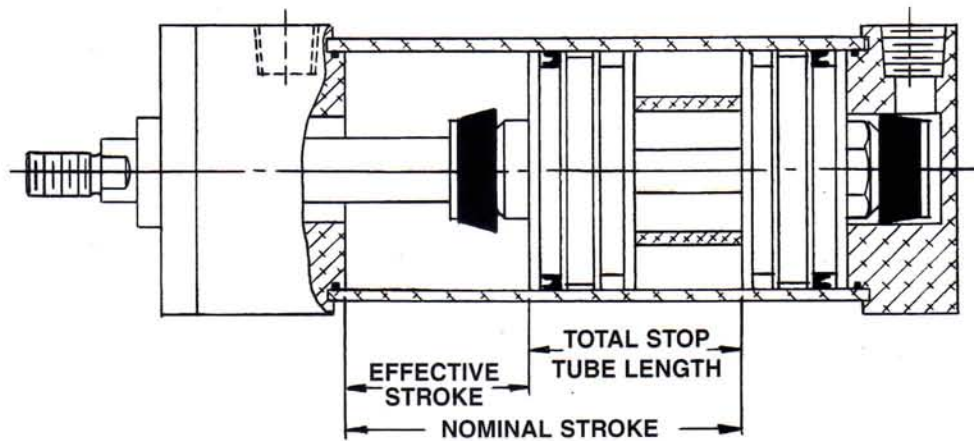

## DUAL PISTON DESIGN

(SERIES I ILLUSTRATED)

All cylinders with cushion front head or both ends

## CYLINDER OPTIONS

### BUMPERS

A Buna N 90 durometer "O" ring is LOCTITED™ to the front head and/or rear cap surface to prevent metal to metal contact. Each bumper increases the cylinder length. Consult factory for bumper diameter. When ordering please specify bumper front head, rear cap or both ends.

### SPRING RETURN OR EXTEND

This light duty spring cylinder is available with a 3" maximum stroke and a rod diameter of 1" or less. The cylinder length will be 1" longer than standard and have an approximate 10 pound pre-load with a spring rate of approximately 10 pounds per inch.

### FAIL-SAFE SPRING RETURN

The cylinder provides fail-safe retraction, if air pressure is lost, with a heavy duty high force spring. It is available in certain models of the Series B and all Series J cylinders. Consult factory for specifications.

### HOLLOW PISTON RODS

They are available on Series B cylinders only. Standard sizes are: 3/4" diameter piston rod with a 1/4" diameter thru hole and 1" diameter piston rod with a 7/16" diameter thru hole.

### PHENOLIC ROD BUSHINGS

Phenolic material is a hard, dense laminated thermoset plastic produced by applying heat and pressure to layers of a fine weave cotton fabric reinforced with a phenolic binder. Phenolic is generally not attacked by common solvents such as alcohol or petroleum products and resists low concentrations of mineral acids (except nitric and chromic). However, in cases of chemical attack by acids such as nitric and chromic, the material retains its strength and may have a long and useful life. Phenolic offers excellent resistance to fruit acids. The material may be used continuously at 200°F.



# SERIES B & J

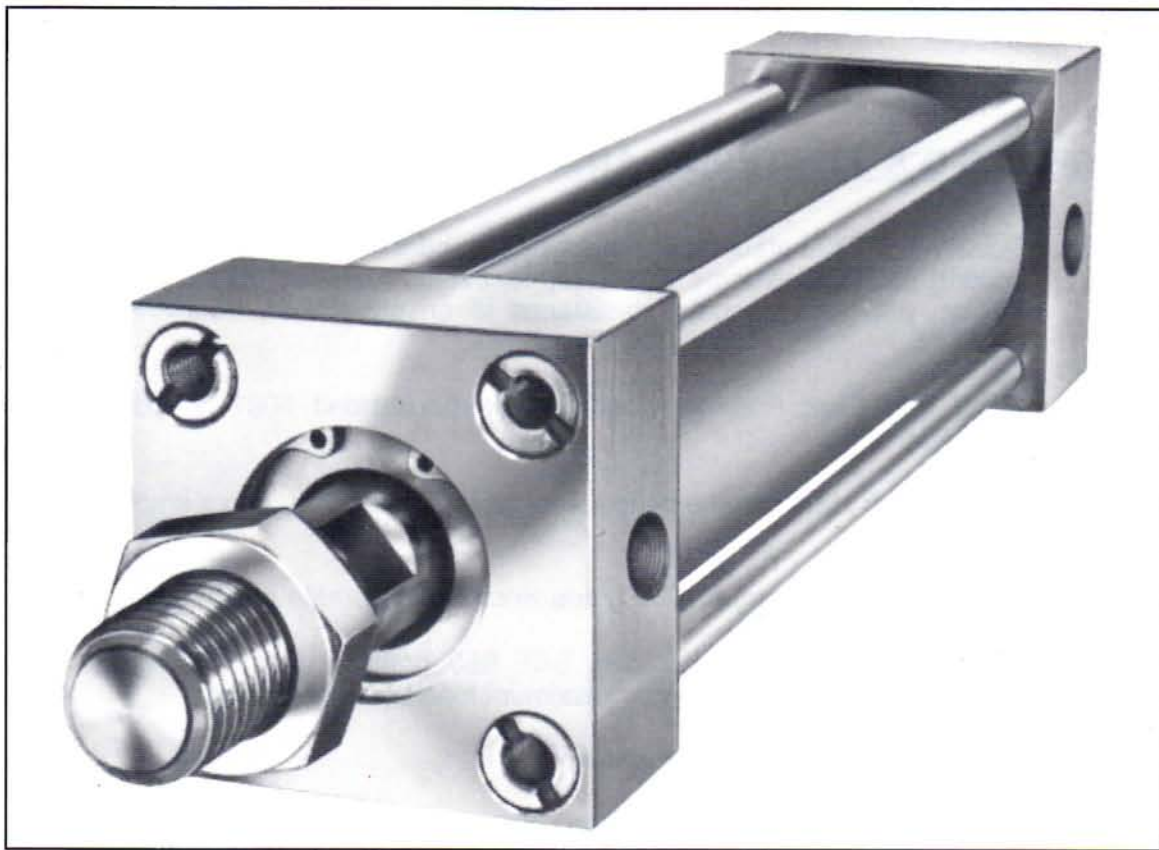

OEM Economy Line  
1 1/4" - 8" Bores  
250 PSI Pneumatic  
250 PSI Non-Shock Hydraulic

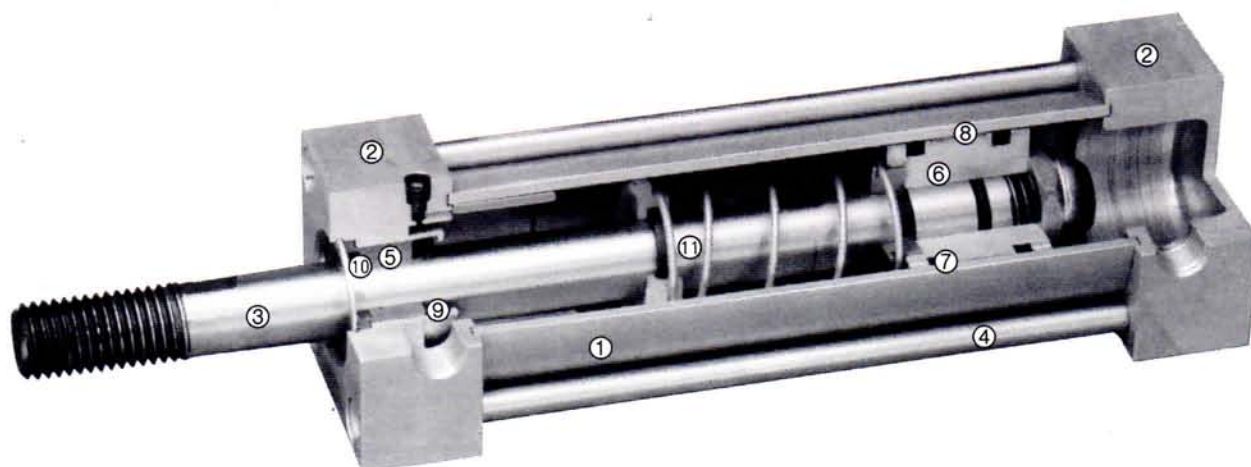

## **SERIES B & J MATERIAL AND DESIGN SPECIFICATIONS**

1. **Tube:** 6063-T832 grade aluminum alloy with hard coated I.D. This anodic coating provides extreme hardness, excellent wear, low coefficient of friction, and high corrosion resistance to ensure longer, trouble-free cycle life.
2. **Head and Cap:** Precision machined from extruded 6061-T6 grade aluminum alloy.
3. **Piston Rod:** Hard chrome plated steel ground and polished to a smooth finish.
4. **Tie Rods:** High strength 1215 grade zinc clear chromate plated steel.
5. **Rod Bushing:** Continuous cast SAE 660 grade bronze bushing is piloted into the head to provide maximum load bearing support.
6. **Piston:** High grade aluminum alloy.
7. **Piston Seals:** Block-Vee type, Buna N material is furnished as standard.
8. **Piston Bearing Strip:** A low friction, dimensionally stable nylon wear band constitutes an excellent bearing surface.
9. **Rod Seal:** Block-Vee type is self-adjusting to ensure proper seal.
10. **Rod Wiper:** Lip type urethane seal cleans piston rod and prevents foreign particles from entering cylinder.
11. **Cushion:** One inch long cushion for deceleration. (Optional)



## ORDERING INSTRUCTIONS FOR SERIES B & J CYLINDERS

4      B490    X      12      DC      Style #1      -      -

Quantity \_\_\_\_\_ ↑

Model \_\_\_\_\_ ↑

Stroke \_\_\_\_\_ ↑

Type of Cushion<sup>1</sup> \_\_\_\_\_ ↑

NC – Non-Cushion  
FC – Front Head  
RC – Rear Cap  
DC – Front Head and Rear Cap

Rod End Style \_\_\_\_\_ ↑

Style #1 Standard Full Male Thread (B Series)  
Style #2 Standard Small Male Thread (J Series)  
Style #3 Optional Female Thread - This Thread and All Optional Rod Ends,  
Please Specify Thread, Length or Depth, Plus "B" Dimension

Options (Most Common)<sup>2</sup> \_\_\_\_\_ ↑

416SS Rod  
303SS Rod, Tie Rods, & Nuts  
Magno Piston (Required for Reed Switch Operation)  
Poly Pak Rod Seal (Required for Hydraulic Application)  
Non-Lube (Teflon Bearing Strip Inside Rod Bushing)  
Pre-Lube (Moly Coat Spray)  
Hard Coat (Head, Cap, & Piston)  
Complete Corrosion Resistance (Hard Coat Option, Plus 303SS Rod, Tie Rods, & Nuts)  
Viton Seals  
Metallic Rod Wiper (Do not use with stainless steel rod.)  
Spring Return or Spring Extend  
Phenolic Rod Bushing  
Rod Boot  
Bumpers<sup>3</sup> (Specify Front Head, Rear Cap, or Both Ends)  
Epoxy Paint  
Adjustable Stroke

Mounting Options and Accessories \_\_\_\_\_ ↑

Ports at Position #1 and Flush Mount Tapped Holes at Position #3 are standard in all cylinders.

Cushion Screw at Position #4 is standard.

**Note:** If not specified, AAC will assume cylinder desired is non-cushion, standard rod end and "B" dimension, hard chrome plated steel rod, Buna N seals, and ports at #1.

<sup>1</sup> 1" long standard. Consult factory for longer cushions.

<sup>2</sup> Consult factory for other options not listed.

<sup>3</sup> Bumpers increase cylinder length. Consult factory.

# SERIES B & J CYLINDER DIMENSIONS

MODEL	BORE	ROD DIA.	EXTEND POWER MULTIPLE	RETRACT POWER MULTIPLE	A	B BD	C CD	D	E	F	G
B120	1¼	⅜	1.23	1.12	2 <sup>29</sup> / <sub>32</sub>	1⅝	⅜-16x1	1.281	1 <sup>13</sup> / <sub>16</sub>	1 <sup>19</sup> / <sub>16</sub>	¼-28x¼
B240	1¾	¾	2.40	1.96	3 <sup>51</sup> / <sub>64</sub>	2¼	¾-10x1½	1.718	2⅜	2⅜	⅝-24x⅜
B300	2	¾	3.14	2.70	3 <sup>51</sup> / <sub>64</sub>	2¼	¾-10x1½	1.875	2⅜	2⅜	⅝-24x⅜
B490	2½	¾	4.91	4.47	3 <sup>51</sup> / <sub>64</sub>	2¼	¾-10x1½	2.203	2 <sup>7</sup> / <sub>8</sub>	2 <sup>7</sup> / <sub>8</sub>	⅝-24x <sup>9</sup> / <sub>16</sub>
B700	3	¾	7.07	6.62	3 <sup>51</sup> / <sub>64</sub>	2¼	¾-10x1½	2.625	3⅜	3⅜	⅝-24x <sup>9</sup> / <sub>16</sub>
B960	3½	1	9.62	8.84	4 <sup>35</sup> / <sub>64</sub>	2⅝	1-8x1⅝	3.219	4	4⅞	⅜-24x1 <sup>1</sup> / <sub>16</sub>
B1600	4½	1	15.90	15.12	4 <sup>35</sup> / <sub>64</sub>	2⅝	1-8x1⅝	4.031	5	5⅞	½-20x1 <sup>1</sup> / <sub>16</sub>
B1960	5	1	19.63	18.85	4 <sup>51</sup> / <sub>64</sub>	2⅝	1-8x1⅝	4.100	5½	5½	½-20x1 <sup>1</sup> / <sub>16</sub>
J2800	6	1½	28.27	26.50	5¾	2½	1¼-12x1⅝	4.875	6½	6½	½-20x <sup>5</sup> / <sub>8</sub>
J5000	8	1½	50.26	48.50	5¾	2½	1¼-12x1⅝	6.440	8½	8½	⅝-18x¾

(1) AH dimension is minimum distance from cylinder face to centerline of rod clevis pin.

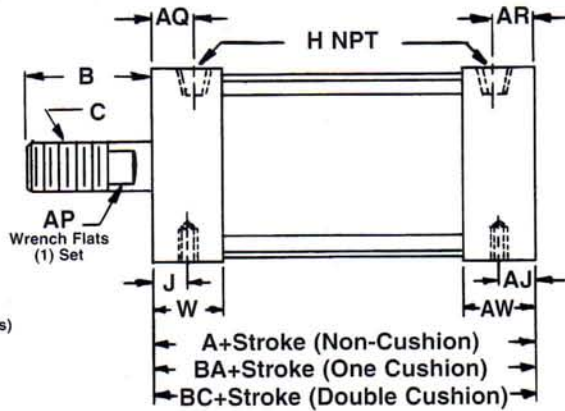
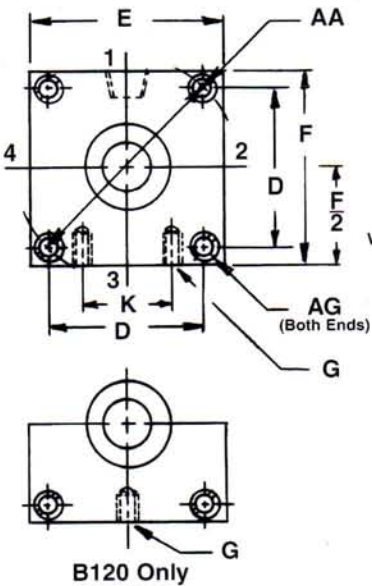

### OPTIONAL ROD END STYLES FOR SERIES B

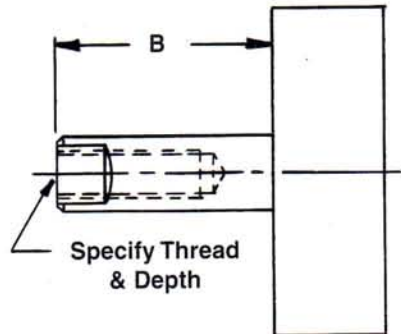
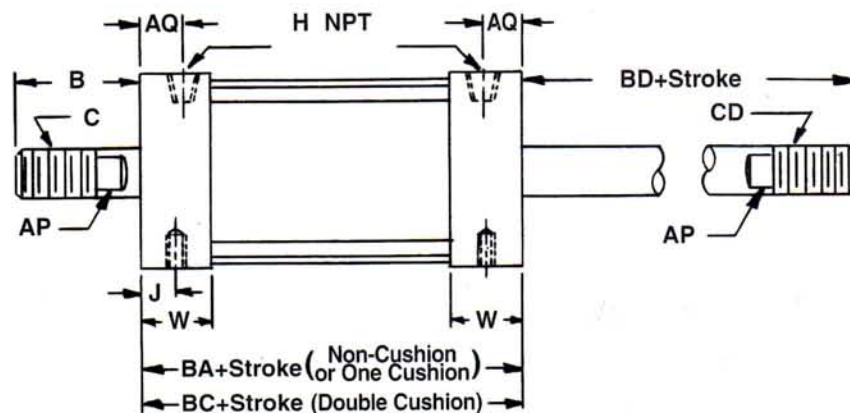
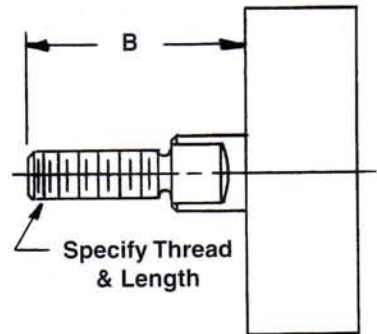



# SERIES B & J CYLINDER DIMENSIONS

H NPT	J	K	W	AA	AG	(1) AH	AJ	AO	AP	AQ	AR	AW	BA	BC	JA
1/8	7/16	—	7/8	1.811	1/4-28x3/8	23/16	7/16	—	5/16	1/2	1/2	7/8	329/32	429/32	—
1/4	19/32	25/32	13/16	2.430	5/16-24x1/2	31/8	19/32	—	5/8	3/4	3/4	13/16	451/64	551/64	—
1/4	19/32	25/32	13/16	2.652	1/4-28x3/8	31/8	19/32	—	5/8	3/4	3/4	13/16	451/64	551/64	—
3/8	19/32	11/4	13/16	3.115	5/16-24x1/2	39/16	19/32	—	5/8	11/16	11/16	13/16	451/64	551/64	—
3/8	19/32	11/4	13/16	3.712	5/16-24x1/2	39/16	19/32	—	5/8	11/16	11/16	13/16	451/64	551/64	—
1/2	23/32	127/32	11/2	4.552	3/8-24x11/16	315/16	23/32	—	7/8	27/32	27/32	11/2	535/64	635/64	—
1/2	23/32	21/2	11/2	5.701	1/2-20x11/16	315/16	23/32	—	7/8	27/32	27/32	11/2	535/64	635/64	—
1/2	3/4	211/16	11/2	5.798	1/2-20x11/16	315/16	3/4	—	7/8	27/32	27/32	11/2	551/64	651/64	—
3/4	11/4	31/4	2	6.894	1/2-20x1/2	37/8	3/4	2	11/4	11/4	3/4	11/2	—	—	61/4
3/4	11/4	41/2	2	9.108	5/8-18x1/2	37/8	3/4	2	11/4	11/4	3/4	11/2	—	—	61/4

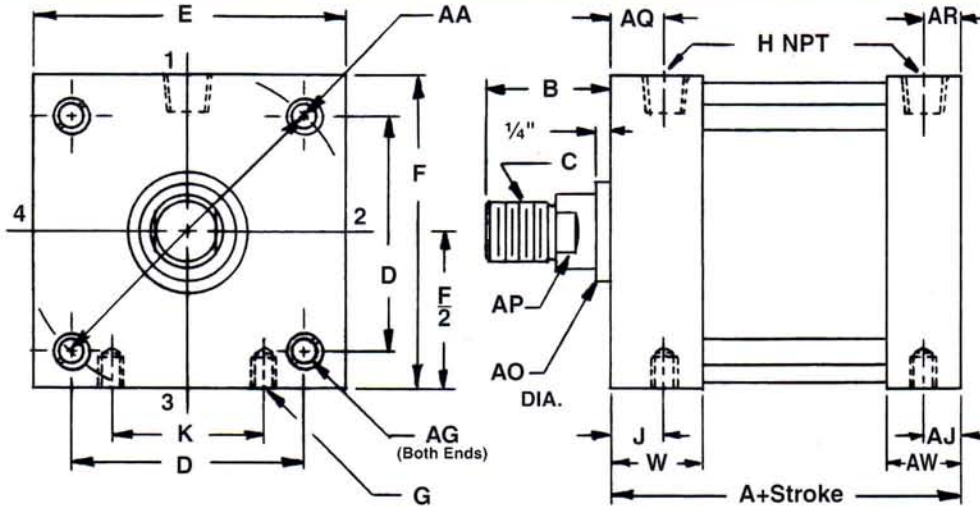

**STANDARD OR CUSHION**

**STYLE #2 Standard Small Male Thread**

**OPTIONAL ROD END STYLES FOR SERIES J**

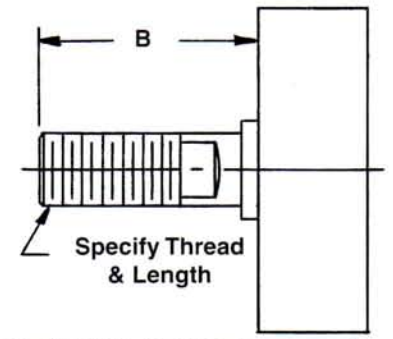

**STYLE #1 Full Male Thread**  
unless specified, "B" dimension furnished standard length

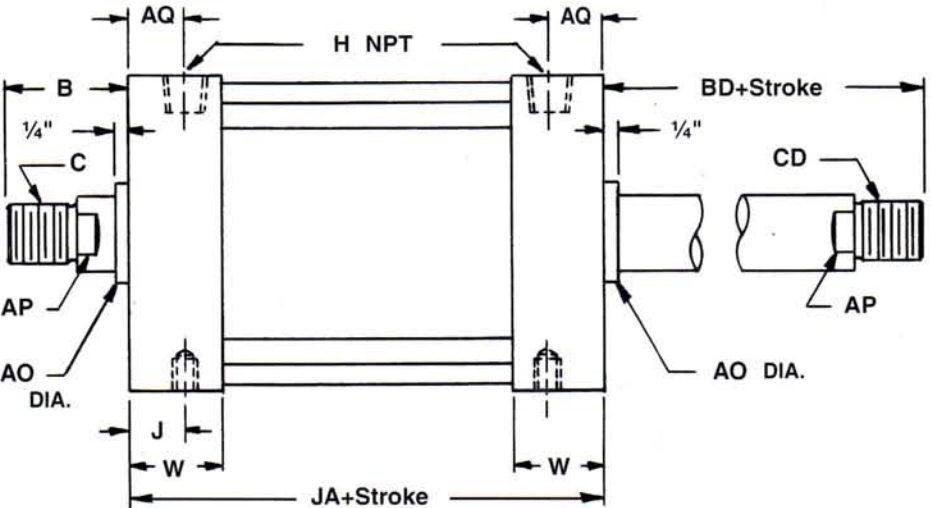

**STANDARD OR CUSHION DOUBLE ROD END**

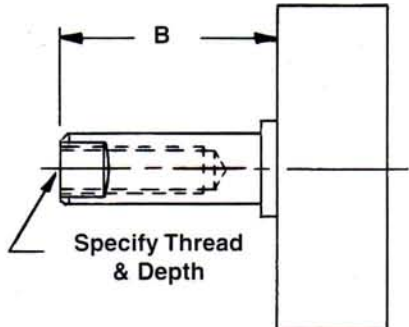

**STYLE #3 Female Thread**  
unless specified, "B" dimension furnished standard length

# SERIES B & J MOUNTING OPTIONS

## CLEVIS MOUNT & PIN

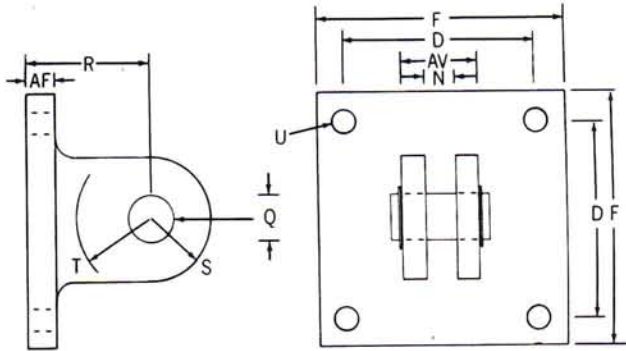

MODEL	PART NO.	D	F	N	Q	R	S	T	U	AF	AV
B120	B120CM	1.281	1 <sup>13</sup> / <sub>16</sub>	¼	¾	1	7/16	9/16	17/64	¼	¾
B240	B240CM	1.718	2 <sup>3</sup> / <sub>8</sub>	½	½	1 <sup>3</sup> / <sub>8</sub>	5/8	7/8	2 <sup>1</sup> / <sub>64</sub>	1 <sup>1</sup> / <sub>32</sub>	1 <sup>1</sup> / <sub>8</sub>
B300	B300CM	1.875	2 <sup>3</sup> / <sub>8</sub>	½	½	1 <sup>3</sup> / <sub>8</sub>	5/8	7/8	17/64	1 <sup>1</sup> / <sub>32</sub>	1 <sup>1</sup> / <sub>8</sub>
B490	B490CM	2.203	2 <sup>7</sup> / <sub>8</sub>	½	5/8	1½	1 <sup>3</sup> / <sub>16</sub>	1	2 <sup>1</sup> / <sub>64</sub>	7/16	1¼
B700	B700CM	2.625	3 <sup>3</sup> / <sub>8</sub>	½	5/8	2 <sup>1</sup> / <sub>8</sub>	1 <sup>3</sup> / <sub>16</sub>	1 <sup>5</sup> / <sub>8</sub>	2 <sup>1</sup> / <sub>64</sub>	3/8	1¼
B960	B960CM	3.219	4	½	¾	2 <sup>1</sup> / <sub>16</sub>	1	1¼	2 <sup>5</sup> / <sub>64</sub>	9/16	1½
B1600	B1600CM	4.031	4 <sup>7</sup> / <sub>8</sub>	½	¾	2 <sup>3</sup> / <sub>8</sub>	1 <sup>1</sup> / <sub>8</sub>	1½	3 <sup>3</sup> / <sub>64</sub>	9/16	1½
B1960	B1960CM	4.031	4 <sup>7</sup> / <sub>8</sub>	½	¾	2 <sup>3</sup> / <sub>8</sub>	1 <sup>1</sup> / <sub>8</sub>	1½	5/8	9/16	1½
J2800	J2800CM	4.875	6 <sup>7</sup> / <sub>16</sub>	1½	1	2¼	1 <sup>5</sup> / <sub>16</sub>	1¼	1 <sup>7</sup> / <sub>32</sub>	5/8	3
J5000	J5000CM	4.875	6 <sup>7</sup> / <sub>16</sub>	1½	1	2¼	1 <sup>5</sup> / <sub>16</sub>	1¼	1 <sup>7</sup> / <sub>32</sub>	5/8	3

NOTE: J5000 cap must be tapped to accept clevis mount.

## EYE MOUNT

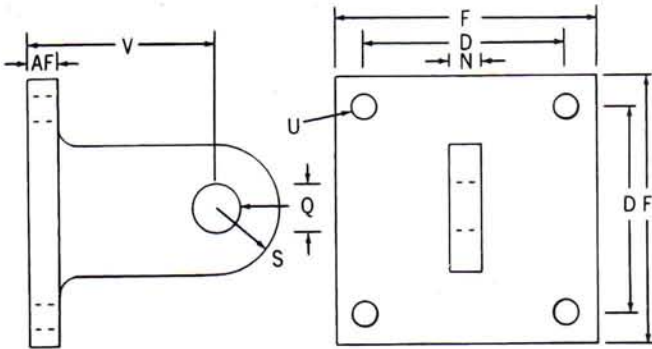

MODEL	PART NO.	D	F	N	Q	S	U	V	AF
B120	BEM-375	1.281	1 <sup>13</sup> / <sub>16</sub>	¼	¾	7/16	17/64	1½	¼
B240	BEM-500	1.718	2 <sup>3</sup> / <sub>8</sub>	½	½	5/8	2 <sup>1</sup> / <sub>64</sub>	1 <sup>7</sup> / <sub>8</sub>	1 <sup>1</sup> / <sub>32</sub>
B300	BEM-501	1.875	2 <sup>3</sup> / <sub>8</sub>	½	½	5/8	17/64	1 <sup>7</sup> / <sub>8</sub>	1 <sup>1</sup> / <sub>32</sub>
B490	BEM-625	2.203	2 <sup>7</sup> / <sub>8</sub>	½	5/8	1 <sup>3</sup> / <sub>16</sub>	2 <sup>1</sup> / <sub>64</sub>	2 <sup>1</sup> / <sub>8</sub>	7/16
B700	BEM-626	2.203	2 <sup>7</sup> / <sub>8</sub>	½	5/8	1 <sup>3</sup> / <sub>16</sub>	2 <sup>1</sup> / <sub>64</sub>	2 <sup>1</sup> / <sub>8</sub>	7/16
B960	BEM-750	3.219	4	½	¾	1	2 <sup>5</sup> / <sub>64</sub>	3	9/16
B1600	BEM-751	4.031	4 <sup>7</sup> / <sub>8</sub>	½	¾	1 <sup>1</sup> / <sub>8</sub>	3 <sup>3</sup> / <sub>64</sub>	3½	9/16
B1960	BEM-752	4.031	4 <sup>7</sup> / <sub>8</sub>	½	¾	1 <sup>1</sup> / <sub>8</sub>	5/8	3½	9/16
J2800	BEM-100	4.875	6 <sup>7</sup> / <sub>16</sub>	1½	1	1 <sup>5</sup> / <sub>16</sub>	1 <sup>7</sup> / <sub>32</sub>	2¼	5/8
J5000	BEM-101	4.875	6 <sup>7</sup> / <sub>16</sub>	1½	1	1 <sup>5</sup> / <sub>16</sub>	1 <sup>7</sup> / <sub>32</sub>	2¼	5/8

NOTE: B700 & J5000 cap must be tapped to accept eye mount.

## FLANGE MOUNT

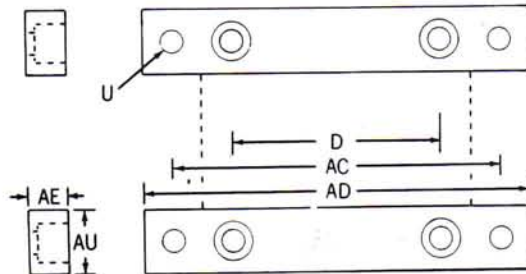

MODEL	PART NO.	D	U	AC	AD	AE	AU
B120	B120FM	1.281	17/64	2 <sup>5</sup> / <sub>16</sub>	2 <sup>3</sup> / <sub>4</sub>	3/8	5/8
B240	B240FM	1.718	2 <sup>1</sup> / <sub>64</sub>	3 <sup>1</sup> / <sub>32</sub>	3 <sup>19</sup> / <sub>32</sub>	7/16	5/8
B300	B300FM	1.875	2 <sup>1</sup> / <sub>64</sub>	3 <sup>1</sup> / <sub>32</sub>	3 <sup>5</sup> / <sub>8</sub>	7/16	¾
B490	B490FM	2.203	2 <sup>1</sup> / <sub>64</sub>	3 <sup>7</sup> / <sub>16</sub>	4	7/16	¾
B700	B700FM	2.625	2 <sup>1</sup> / <sub>64</sub>	3 <sup>7</sup> / <sub>8</sub>	4½	7/16	¾
B960	B960FM	3.219	2 <sup>5</sup> / <sub>64</sub>	5 <sup>1</sup> / <sub>16</sub>	5 <sup>15</sup> / <sub>16</sub>	5/8	1
B1600	B1600FM	4.031	3 <sup>3</sup> / <sub>64</sub>	6 <sup>1</sup> / <sub>16</sub>	7	5/8	1
B1960	B1960FM	4.100	3 <sup>3</sup> / <sub>64</sub>	6 <sup>9</sup> / <sub>16</sub>	7½	5/8	1
J2800	J2800FM	4.875	1 <sup>7</sup> / <sub>32</sub>	7 <sup>5</sup> / <sub>8</sub>	8½	¾	1 <sup>5</sup> / <sub>8</sub>
J5000	J5000FM	6.440	4 <sup>1</sup> / <sub>64</sub>	10	11¼	7/8	2



# SERIES B & J MOUNTING OPTIONS

## END LUG MOUNT

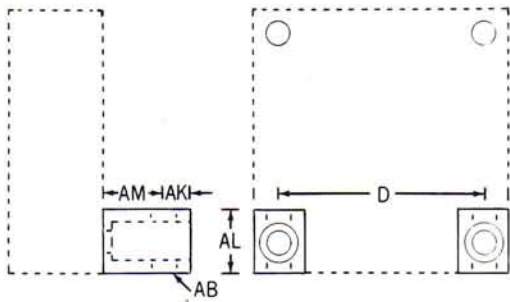

MODEL	PART NO.	D	AB	AK	AL	AM
B120	B120ELM	1.281	.257	5/16	9/16	1/2
B240	B240ELM	1.718	.323	5/16	1 1/16	5/8
B300	B120ELM	1.875	.257	5/16	9/16	1/2
B490	B240ELM	2.203	.323	5/16	1 1/16	5/8
B700	B240ELM	2.625	.323	5/16	1 1/16	5/8
B960	B960ELM	3.219	33/64	3/8	7/8	1
B1600	B1600ELM	4.031	33/64	3/8	1	1
B1960	B1960ELM	4.100	33/64	3/8	1 3/8	1
J2800	J2800ELM	4.875	33/64	3/8	1 5/8	1
J5000	J5000ELM	6.440	33/64	3/4	2	1 1/4

NOTE: (4) pieces total, (2) for each end.

## FRONT OR REAR TRUNNION

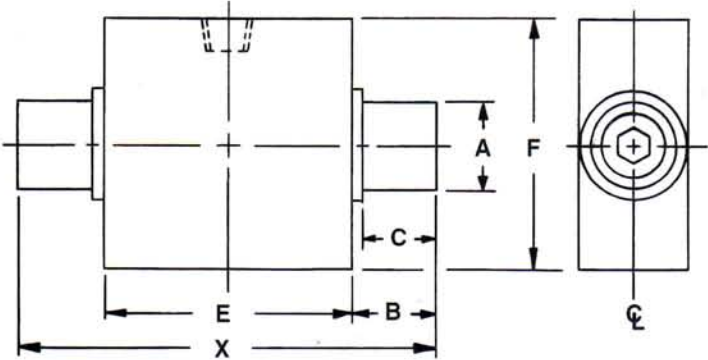

MODEL	A	B	C	E	F	X
B120	3/8	7/16	3/8	1 13/16	1 13/16	2 11/16
B240	1	15/16	7/8	2 3/8	2 3/8	4 1/4
B300	1	15/16	7/8	2 3/8	2 3/8	4 1/4
B490	1	15/16	7/8	2 7/8	2 7/8	4 3/4
B700	1	15/16	7/8	3 3/8	3 3/8	5 1/4
B960	1	15/16	7/8	4	4 1/8	5 7/8
B1600	1	15/16	7/8	5	5 1/8	6 7/8
B1960	1	15/16	7/8	5 1/2	5 1/2	7 3/8
J2800	1 3/8	1 3/8	1 1/4	6 1/2	6 1/2	9 1/4
J5000	1 3/8	1 3/8	1 1/4	8 1/2	8 1/2	11 1/4

## CENTER TRUNNION

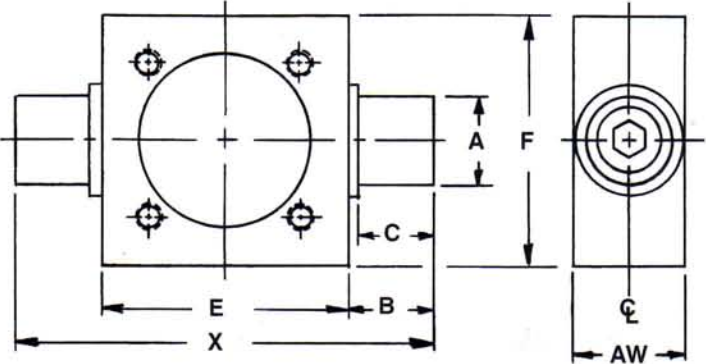

MODEL	A	B	C	E	F	X	AW
B240	1	15/16	7/8	2 7/8	2 7/8	4 3/4	1 3/16
B300	1	15/16	7/8	2 7/8	2 7/8	4 3/4	1 3/16
B490	1	15/16	7/8	3 3/8	3 3/8	5 1/4	1 3/16
B700	1	15/16	7/8	4	4 1/8	5 7/8	1 1/2
B960	1	15/16	7/8	5	5 1/8	6 7/8	1 1/2
B1600	1	15/16	7/8	5 1/2	5 1/2	7 3/8	1 1/2
B1960	1	15/16	7/8	6 1/2	6 1/2	8 3/8	1 1/2
J2800	1 3/8	1 3/8	1 1/4	8 1/2	8 1/2	11 1/4	1 1/2

NOTE: Unless specified, trunnion located in the center of cylinder.

# SERIES B & J ACCESSORIES

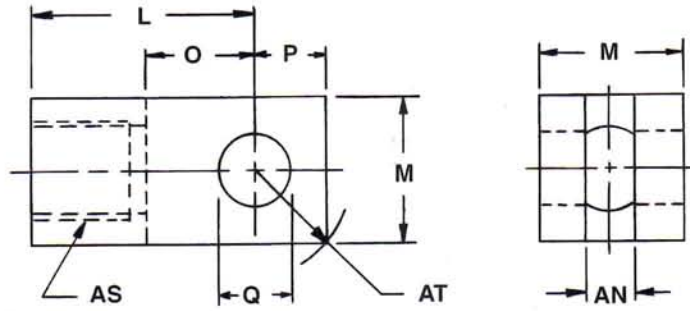

**ROD CLEVIS**

MODEL	PART NO.	L	M	O	P	Q	AN	AS	AT
B120	BRC-375	1 <sup>11</sup> / <sub>32</sub>	3/4	17/32	3/8	3/8	1/4	3/8-16 x 7/8	17/32
B240-300	BRC-750	1 <sup>7</sup> / <sub>8</sub>	1 <sup>1</sup> / <sub>8</sub>	3/4	9/16	1/2	1/2	3/4-10 x 1	5 <sup>1</sup> / <sub>64</sub>
B490-700	BRC-751	2 <sup>1</sup> / <sub>16</sub>	1 <sup>1</sup> / <sub>8</sub>	15/16	9/16	5/8	1/2	3/4-10 x 1	5 <sup>1</sup> / <sub>64</sub>
B960-1600 -1960	BRC-100	2 <sup>5</sup> / <sub>16</sub>	1 <sup>1</sup> / <sub>2</sub>	1 <sup>1</sup> / <sub>8</sub>	3/4	3/4	1/2	1-8 x 1	1 <sup>1</sup> / <sub>16</sub>
J2800-5000	BRC-125	3	2	1	1	1	1	1 <sup>1</sup> / <sub>4</sub> -12 x 1 <sup>5</sup> / <sub>8</sub>	1 <sup>27</sup> / <sub>64</sub>

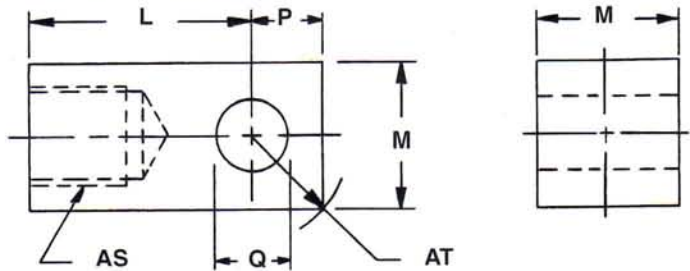

**ROD EYE**

MODEL	PART NO.	L	M	P	Q	AS	AT
B120	BRE-375	1 <sup>11</sup> / <sub>32</sub>	3/4	3/8	3/8	3/8-16 x 7/8	17/32
B240-300	BRE-750	1 <sup>7</sup> / <sub>8</sub>	1 <sup>1</sup> / <sub>8</sub>	9/16	1/2	3/4-10 x 1	5 <sup>1</sup> / <sub>64</sub>
B490-700	BRE-751	2 <sup>1</sup> / <sub>16</sub>	1 <sup>1</sup> / <sub>8</sub>	9/16	5/8	3/4-10 x 1	5 <sup>1</sup> / <sub>64</sub>
B960-1600 -1960	BRE-100	2 <sup>5</sup> / <sub>16</sub>	1 <sup>1</sup> / <sub>2</sub>	3/4	3/4	1-8 x 1	1 <sup>1</sup> / <sub>16</sub>
J2800-5000	BRE-125	3	2	1	1	1 <sup>1</sup> / <sub>4</sub> -12 x 1 <sup>5</sup> / <sub>8</sub>	1 <sup>27</sup> / <sub>64</sub>

## PIVOT PIN & SNAPS

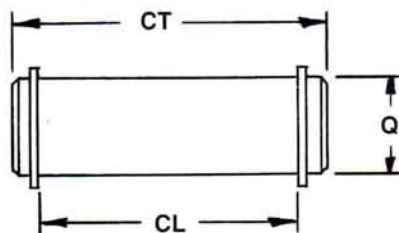

MODEL	PART NO.	Q	CL	CT	W/ROD CLEVIS
B120	BP-375	3/8	1 <sup>3</sup> / <sub>16</sub>	1 <sup>1</sup> / <sub>16</sub>	BRC-375
B240-300	BP-500	1/2	1 <sup>3</sup> / <sub>16</sub>	1 <sup>7</sup> / <sub>16</sub>	BRC-750
B490-700	BP-625	5/8	1 <sup>5</sup> / <sub>16</sub>	1 <sup>9</sup> / <sub>16</sub>	BRC-751
B960-1600 -1960	BP-750	3/4	1 <sup>9</sup> / <sub>16</sub>	1 <sup>7</sup> / <sub>8</sub>	BRC-100
J2800-5000	BP-1100	1	2 <sup>1</sup> / <sub>16</sub>	2 <sup>5</sup> / <sub>16</sub>	BRC-125



# MULTIPLE POSITION CYLINDERS

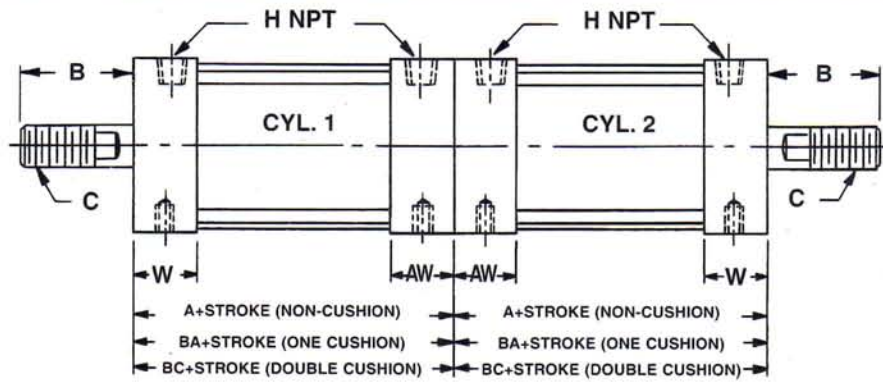

**SERIES B MULTIPLE POSITION  
TANDEM BACK TO BACK**

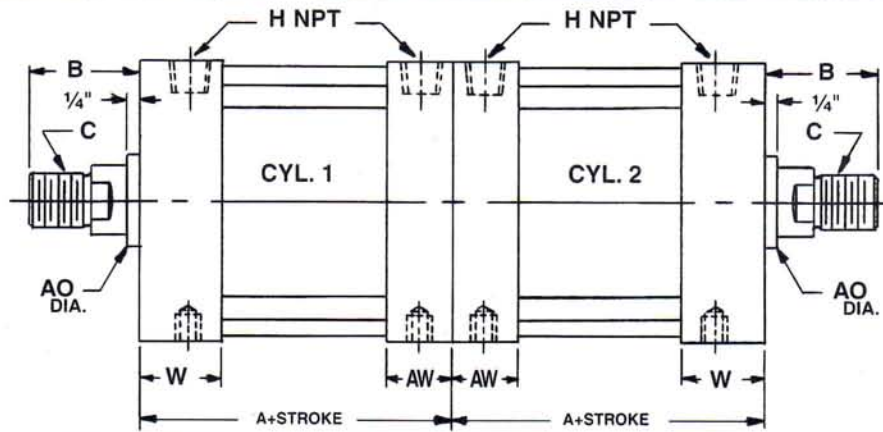

**SERIES J MULTIPLE POSITION TANDEM BACK TO BACK STANDARD OR CUSHION**

CONSULT FACTORY FOR ORDERING INSTRUCTIONS

## SERIES B & J CYLINDER DIMENSIONS

MODEL	BORE	ROD DIA.	A	B	C	H NPT	W	AO	AW	BA	BC
B120	1 1/4	3/8	2 29/32	1 5/8	3/8-16 x 1	1/8	7/8	—	7/8	3 29/32	4 29/32
B240	1 3/4	3/4	3 51/64	2 1/4	3/4-10 x 1 1/2	1/4	1 3/16	—	1 3/16	4 51/64	5 51/64
B300	2	3/4	3 51/64	2 1/4	3/4-10 x 1 1/2	1/4	1 3/16	—	1 3/16	4 51/64	5 51/64
B490	2 1/2	3/4	3 51/64	2 1/4	3/4-10 x 1 1/2	3/8	1 3/16	—	1 3/16	4 51/64	5 51/64
B700	3	3/4	3 51/64	2 1/4	3/4-10 x 1 1/2	3/8	1 3/16	—	1 3/16	4 51/64	5 51/64
B960	3 1/2	1	4 35/64	2 5/8	1-8 x 1 5/8	1/2	1 1/2	—	1 1/2	5 35/64	6 35/64
B1600	4 1/2	1	4 35/64	2 5/8	1-8 x 1 5/8	1/2	1 1/2	—	1 1/2	5 35/64	6 35/64
B1960	5	1	4 51/64	2 5/8	1-8 x 1 5/8	1/2	1 1/2	—	1 1/2	5 51/64	6 51/64
J2800	6	1 1/2	5 3/4	2 1/2	1 1/4-12 x 1 5/8	3/4	2	2	1 1/2	—	—
J5000	8	1 1/2	5 3/4	2 1/2	1 1/4-12 x 1 5/8	3/4	2	2	1 1/2	—	—

# MULTIPLE POSITION CYLINDERS

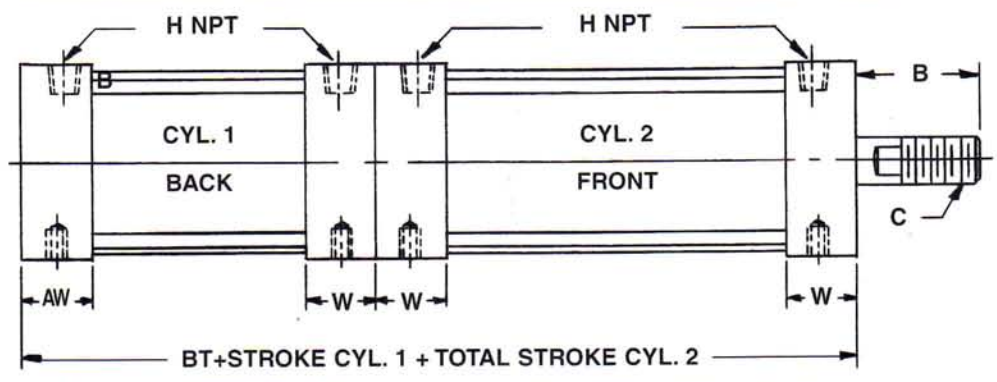

**SERIES B MULTIPLE POSITION TANDEM FRONT TO BACK**  
 CONSULT FACTORY FOR ONE CENTER HEAD DESIGN

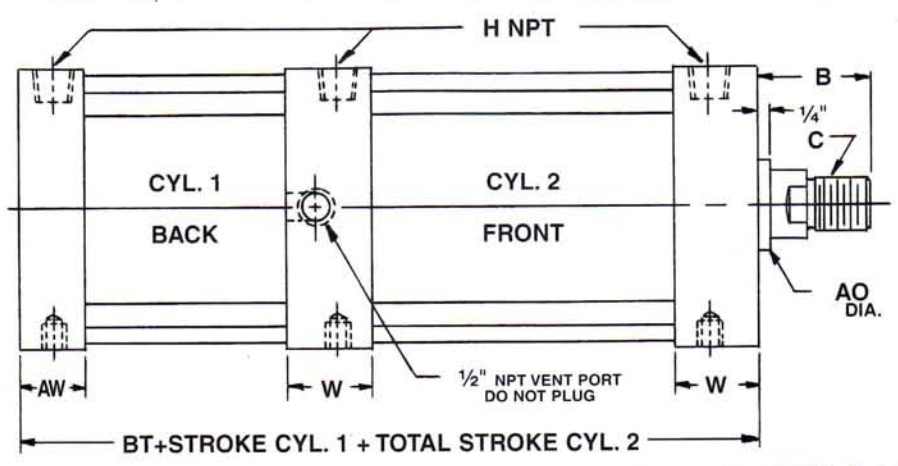

**SERIES J MULTIPLE POSITION TANDEM FRONT TO BACK**  
 CONSULT FACTORY FOR ORDERING INSTRUCTIONS

## SERIES B & J CYLINDER DIMENSIONS

MODEL	BORE	ROD DIA.	B	C	H NPT	W	AO	AW	BT
B120	1 1/4	3/8	1 5/8	3/8-16 x 1	1/8	7/8	—	7/8	6 13/16
B240	1 3/4	3/4	2 1/4	3/4-10 x 1 1/2	1/4	1 3/16	—	1 3/16	8 19/32
B300	2	3/4	2 1/4	3/4-10 x 1 1/2	1/4	1 3/16	—	1 3/16	8 19/32
B490	2 1/2	3/4	2 1/4	3/4-10 x 1 1/2	3/8	1 3/16	—	1 3/16	8 19/32
B700	3	3/4	2 1/4	3/4-10 x 1 1/2	3/8	1 3/16	—	1 3/16	8 19/32
B960	3 1/2	1	2 5/8	1-8 x 1 5/8	1/2	1 1/2	—	1 1/2	10 3/32
B1600	4 1/2	1	2 5/8	1-8 x 1 5/8	1/2	1 1/2	—	1 1/2	10 3/32
B1960	5	1	2 5/8	1-8 x 1 5/8	1/2	1 1/2	—	1 1/2	10 19/32
J2800	6	1 1/2	2 1/2	1 1/4-12 x 1 5/8	3/4	2	2	1 1/2	11
J5000	8	1 1/2	2 1/2	1 1/4-12 x 1 5/8	3/4	2	2	1 1/2	11



# TANDEM COMMON ROD CYLINDERS

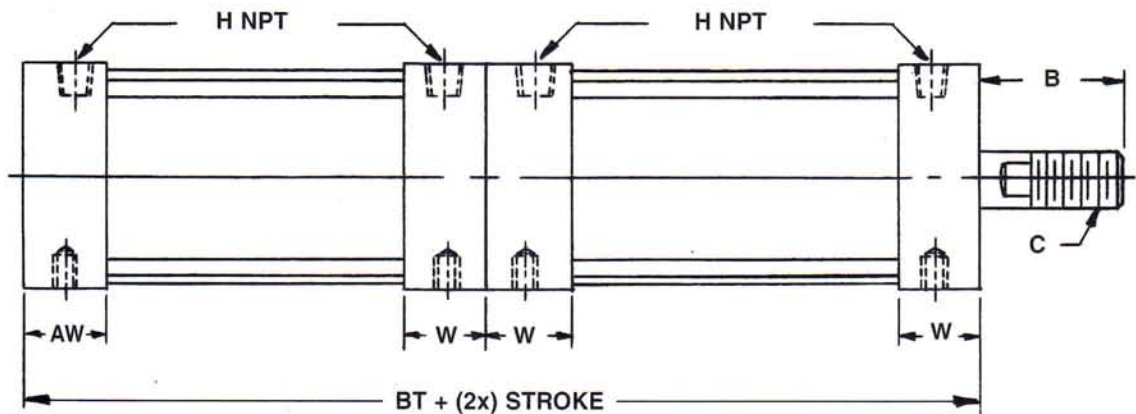

## SERIES B TANDEM FRONT TO BACK WITH COMMON ROD

CONSULT FACTORY FOR ORDERING INSTRUCTIONS

## SERIES B CYLINDER DIMENSIONS

MODEL	BORE	ROD DIA.	B	C	H NPT	W	AW	BT
B120	1¼	⅜	1⅝	⅝-16 x 1	⅛	⅞	⅞	6 <sup>13</sup> / <sub>16</sub>
B240	1¾	¾	2¼	¾-10 x 1½	¼	1 <sup>3</sup> / <sub>16</sub>	1 <sup>3</sup> / <sub>16</sub>	8 <sup>19</sup> / <sub>32</sub>
B300	2	¾	2¼	¾-10 x 1½	¼	1 <sup>3</sup> / <sub>16</sub>	1 <sup>3</sup> / <sub>16</sub>	8 <sup>19</sup> / <sub>32</sub>
B490	2½	¾	2¼	¾-10 x 1½	⅜	1 <sup>3</sup> / <sub>16</sub>	1 <sup>3</sup> / <sub>16</sub>	8 <sup>19</sup> / <sub>32</sub>
B700	3	¾	2¼	¾-10 x 1½	⅜	1 <sup>3</sup> / <sub>16</sub>	1 <sup>3</sup> / <sub>16</sub>	8 <sup>19</sup> / <sub>32</sub>
B960	3½	1	2⅝	1-8 x 1⅝	½	1½	1½	10 <sup>3</sup> / <sub>32</sub>
B1600	4½	1	2⅝	1-8 x 1⅝	½	1½	1½	10 <sup>3</sup> / <sub>32</sub>
B1960	5	1	2⅝	1-8 x 1⅝	½	1½	1½	10 <sup>19</sup> / <sub>32</sub>

PARTS LIST

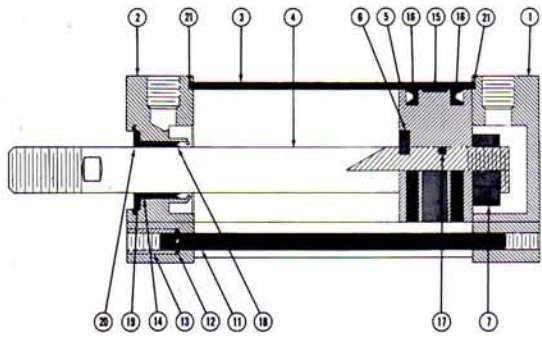

SERIES B DOUBLE ACTING

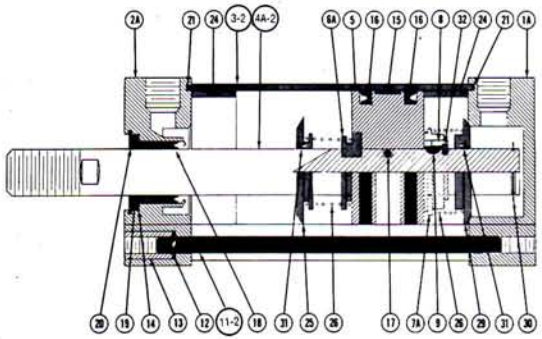

SERIES B DOUBLE CUSHION

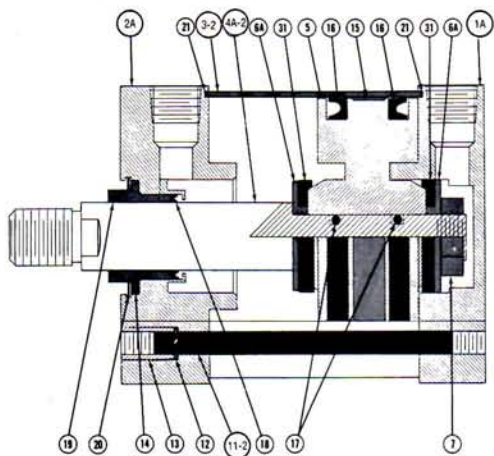

SERIES J DOUBLE CUSHION

P/N	DESCRIPTION	QTY.
1	REAR CAP	1
1A	REAR CAP CUSHIONED (WITH P/N 27 & 18)	1
2	FRONT HEAD	1
2A	FRONT HEAD CUSHIONED (WITH P/N 27 & 28)	1
3	CYLINDER TUBE	1
3-1	CYLINDER TUBE (CUSHION ONE END)	1
3-2	CYLINDER TUBE (DOUBLE CUSHION)	1
4	PISTON ROD	1
4A	PISTON ROD — REAR CUSHION (WITH P/N 7A, 8 & 9)	1
4A-1	PISTON ROD — FRONT CUSHION	1
4A-2	PISTON ROD — DOUBLE CUSHION (WITH P/N 7A, 8 & 9)	1
4A-B	PISTON ROD — DOUBLE ROD END (WITH P/N 7A, 8 & 9)	1
5	PISTON	1
6	PISTON SUPPORT	1*
6A	PISTON SUPPORT CUSHIONED	1*
7	PISTON NUT	1
7A	PISTON NUT (REAR CUSHION & DOUBLE ROD END)	1*
8-9	SPLIT SCREW & KEY	1*
10	PISTON ROD JAM NUT	1*
11	TIE ROD	4
11-1	TIE ROD (CUSHION ONE END)	4
11-2	TIE ROD (DOUBLE CUSHION)	4
12	TIE ROD LOCKWASHER	4
13	TIE ROD NUT	4
14	ROD BUSHING	1
15	PISTON BEARING STRIP	1
16	PISTON SEAL	2
17	PISTON ROD "O" RING	1*
18	ROD SEAL (STANDARD)	1
18PP	ROD SEAL (HYDRAULIC)	1
19	ROD WIPER	1
20	BUSHING RETAINING RING	1
21	TUBE SEAL GASKET OR ("O" RING J SERIES)	2
24	CUSHION INSERT	1*†
25	FRONT CUSHION	1*
26	CUSHION SPRING	1*†
27	CUSHION SCREW	1†
28	CUSHION SCREW "O" RING	1†
29	REAR CUSHION	1*
30	REAR CUSHION RETAINING RING	1*
31	CUSHION SEAL	1†
32	SPLIT SCREW SUPPORT	1*

NOTE: \* Difference in quantities between series  
 † Per cushion

REPAIR KITS

Repair kits containing all wearable replacement parts are available.

Please specify cylinder model, single or double ended, type of cushion, air or hydraulic operated and any options which affect repair kit.

**(B&J) STANDARD REPAIR KIT CONTAINS:** P/N 14, 15, 16, 17, 18, 19, 20 & 21.

**(B) REAR CUSHION REPAIR KIT CONTAINS:** Standard repair kit plus P/N 26, 28, 30 & 31.

**(B) FRONT CUSHION REPAIR KIT CONTAINS:** Standard repair kit plus P/N 26, 28 & 31.

**(J) CUSHION REPAIR KIT CONTAINS:** Standard repair kit plus P/N 28 & 31.

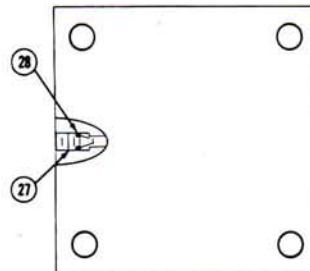

SERIES B & J CUSHION ADJUSTMENT



# SERIES R

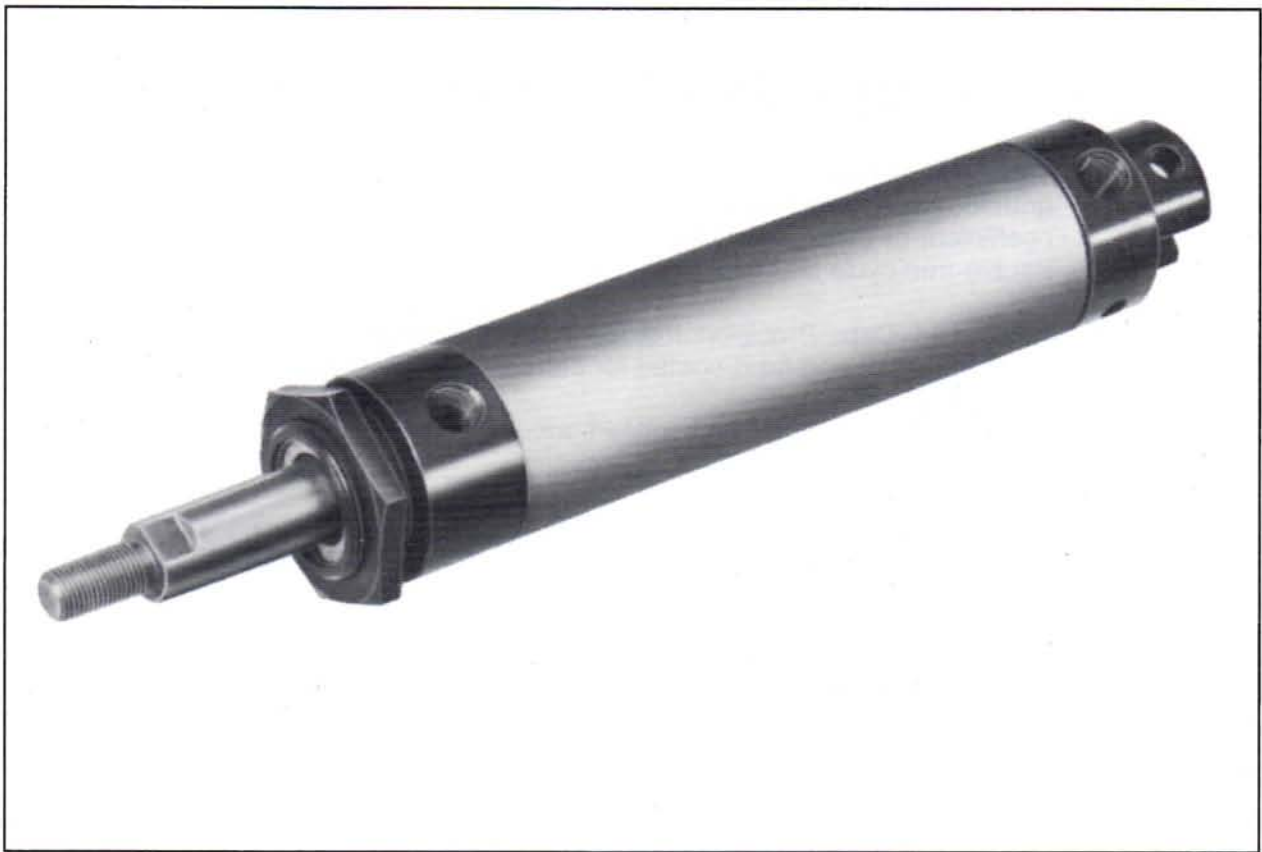

Space Saving Applications  
1 3/4" - 3" Bores  
250 PSI Pneumatic  
250 PSI Non-Shock Hydraulic

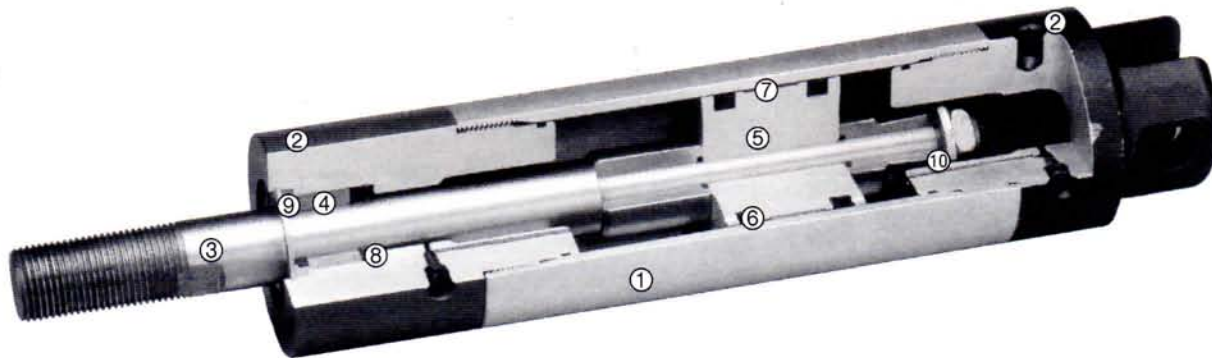

### **SERIES R MATERIAL AND DESIGN SPECIFICATIONS**

1. **Tube:** 6063-T832 grade aluminum alloy with hard coated I.D. This anodic coating provides extreme hardness, excellent wear, low coefficient of friction, and high corrosion resistance to ensure longer, trouble-free cycle life.
2. **Head and Cap:** Precision machined from extruded 6061-T6 grade aluminum alloy and hard coated for corrosion resistance as standard.
3. **Piston Rod:** Hard chrome plated steel ground and polished to a smooth finish.
4. **Rod Bushing:** Continuous cast SAE 660 grade bronze bushing is piloted into the head to provide maximum load bearing support.
5. **Piston:** High grade aluminum alloy.
6. **Piston Seals:** Block-Vee type, Buna N material is furnished as standard.
7. **Piston Bearing Strip:** A low friction, dimensionally stable nylon wear band constitutes an excellent bearing surface.
8. **Rod Seal:** Block-Vee type is self-adjusting to ensure proper seal.
9. **Rod Wiper:** Lip type urethane seal cleans piston rod and prevents foreign particles from entering cylinder.
10. **Cushion:** Self-adjusting urethane cup moves into the head/cap to insure a positive seal and allows air to meter across the cushion screw. This method provides a fast breakaway and more precise adjustment. (Optional)



## ORDERING INSTRUCTIONS FOR SERIES R CYLINDERS

	4	R300	X	6	Clevis Mount	DC	Style #1	-	-	
Quantity	↑			↑	↑	↑	↑	↑	↑	↑
Model	↑									
Stroke	↑									
Mounting Style	↑									
Type of Cushion	↑									
	<ul style="list-style-type: none"> <li>NC – Non-Cushion</li> <li>FC – Front Head</li> <li>RC – Rear Cap</li> <li>DC – Front Head and Rear Cap</li> </ul>									
Rod End Style	↑									
	<ul style="list-style-type: none"> <li>Style #1 Standard Full Male Thread (R300, R490, &amp; R700)</li> <li>Style #2 Standard Small Male Thread (R240)</li> <li>Style #3 Optional Female Thread - This Thread and all Optional Rod Ends, Please Specify Thread, Length or Depth, Plus "B" Dimension</li> </ul>									
Options (Most Common) <sup>1</sup>	↑									
	<ul style="list-style-type: none"> <li>416SS Rod</li> <li>303SS Rod</li> <li>Magno Piston (Required for Reed Switch Operation)<sup>2</sup></li> <li>Poly Pak Rod Seal (Required for Hydraulic Application)</li> <li>Non-Lube (Teflon Bearing Strip Inside Rod Bushing)</li> <li>Pre-Lube (Moly Coat Spray)</li> <li>Hard Coat (Piston Only)</li> <li>Complete Corrosion Resistance (Hard Coat Option, Plus 303SS Rod)</li> <li>Viton Seals</li> <li>Metallic Rod Wiper (Do not use with stainless steel rod.)</li> <li>Spring Return or Spring Extend</li> <li>Phenolic Rod Bushing</li> <li>Bumpers<sup>3</sup> (Specify Front Head, Rear Cap, or Both Ends)</li> <li>Epoxy Paint</li> </ul>									
Cylinder Accessories	↑									

**Note:** If not specified, AAC will assume cylinder desired is non-cushion, standard rod end and "B" dimension, hard chrome plated steel rod, and Buna N seals.

<sup>1</sup> Consult factory for other options not listed.

<sup>2</sup> A tie rod is attached to outside of cylinder to mount switch.

<sup>3</sup> Bumpers increase cylinder length. Consult factory.

# SERIES R CYLINDER & ACCESSORIES DIMENSIONS

MODEL	BORE	ROD DIA.	EXTEND POWER MULTIPLE	RETRACT POWER MULTIPLE	A	B	C	D	E	F	G	H NPT	J	K	L	M	N	P	Q	R	S	T	U	V
R240	1 3/4	3/4	2.40	1.96	5 7/16	1 1/2	1/2-20x1	5/8	7/8	2	1 1/2	1/4	1 25/32	1 5/16	1 3/32	3/4	1 1/16	1 1/2-16UN-2A	3/8	2	3 1/32	3/8	1 5/32	5/16
R300	2	3/4	3.14	2.70	6 3/8	2	3/4-16x1 1/2	5/8	1 1/16	2 1/4	1 3/4	1/4	1 57/64	1 29/64	5/8	3/4	1 1/16	2-16UN-2A	3/8	2 1/2	1 1/4	1/2	1 17/32	3/8
R490	2 1/2	3/4	4.91	4.47	6 9/16	2	3/4-16x1 1/2	5/8	1 7/64	2 3/4	2 1/4	3/8	1 29/32	1 15/32	4 3/64	1	1 1/16	2 1/2-16UN-2A	3/8	3	1 27/64	1/2	1 17/32	3/8
R700	3	1	7.07	6.28	6 5/8	2 1/2	1-14x2	7/8	1	3 1/4	2 3/4	3/8	2	1 9/16	9/16	1 1/4	1 1/16	3-16UN-2A	3/8	3 1/2	1 7/16	3/4	3/4	7/16

## CLEVIS MOUNT (Furnished with Clevis Pin)

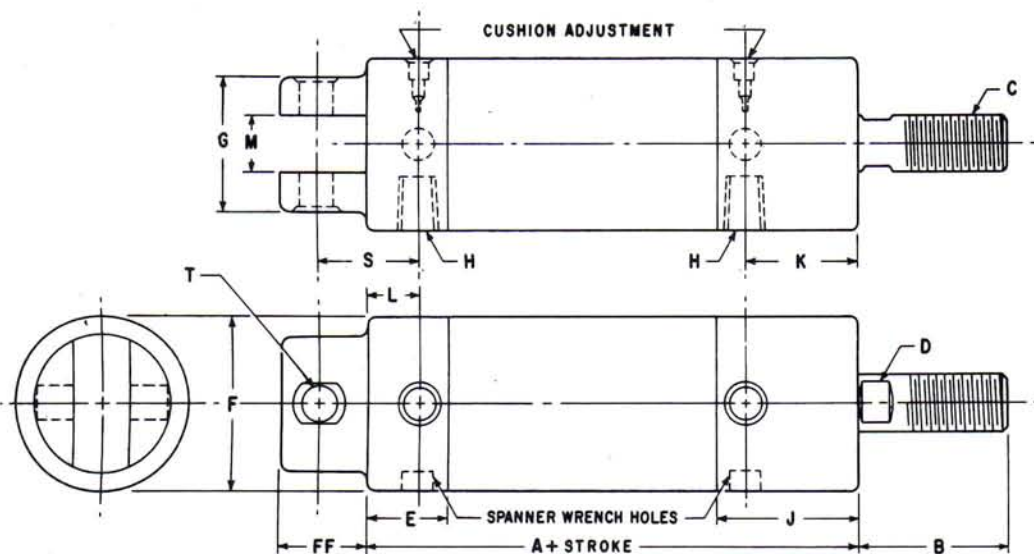

## ROD END STYLES

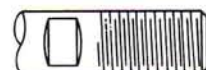

Style #1 Standard Full Male Thread on Models R300, R490 & R700

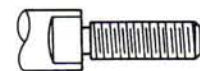

Style #2 Standard Small Male Thread on Model R240



Style #3 Optional Female Thread

## NOSE MOUNT (Nose Mount Nut Optional)

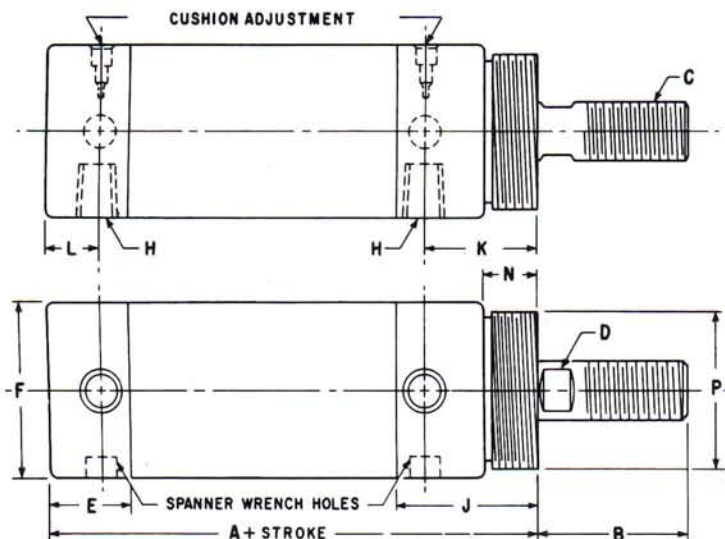

For female thread and optional rod ends, please specify thread, length or depth, plus "B" dimension.

## NOSE MOUNT NUT

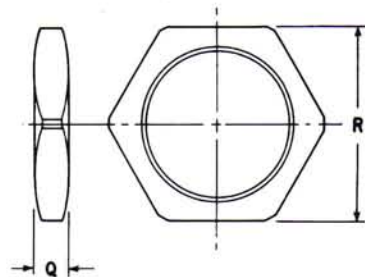



# SERIES R CYLINDER & ACCESSORIES DIMENSIONS

W	X	Y	Z	AA DIA.	AC	AD	BB	CC	DD	EE	FF	GG	HH	JJ	KK	LL	MM	NN	OO	PP	RR	SS	TT	VV	XX DIA.	YY RAD.
17/16	13/4	11/4	3/4	1/4	125/32	2	2	11/2	13/4	3/4	1	3/4	1/2	3/8	1	1/2-20	15/8	1/4	21/2	15/8	11/4	7/16	1/4	5/16	1	1/8
19/16	21/4	15/8	3/4	5/16	125/32	2	211/16	21/8	11/2	3/4	11/8	11/8	9/16	1/2	11/8	3/4-16	15/8	1/4	21/2	15/8	11/4	7/16	1/4	5/16	1	1/8
19/16	21/4	15/8	1	5/16	125/32	2	23/4	21/8	13/4	1	11/4	11/8	5/8	1/2	11/8	3/4-16	23/8	5/16	31/2	21/4	17/8	5/8	1/4	1/2	13/8	3/16
21/4	31/4	23/8	11/4	3/8	21/32	27/32	33/8	23/4	2	11/4	15/8	13/8	7/8	3/4	13/8	1-14	23/8	5/16	31/2	21/4	17/8	5/8	1/4	1/2	13/8	3/16

## BASIC MOUNT

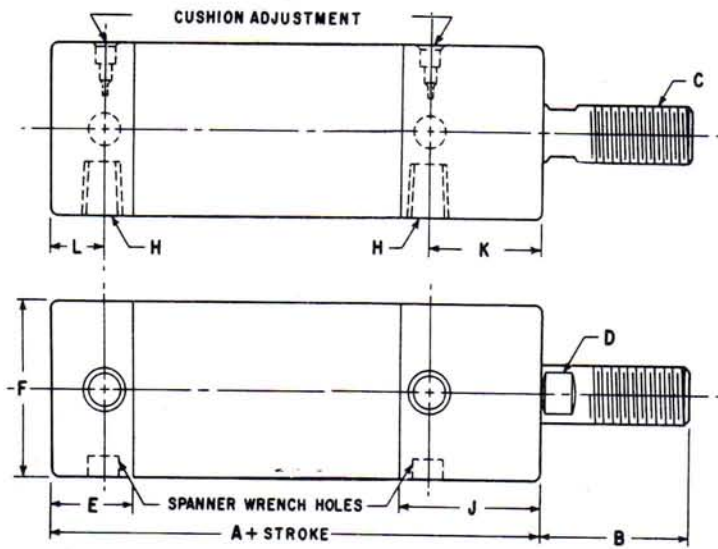

## FOOT MOUNT BRACKET

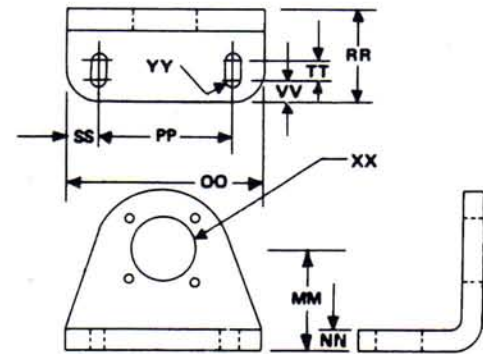

ATTACHES TO BASIC MOUNT. HEAD AND CAP MUST BE TAPPED TO ATTACH.

## ROD CLEVIS

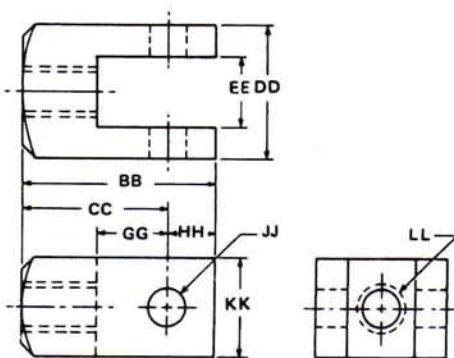

## PIVOT PIN & SNAPS

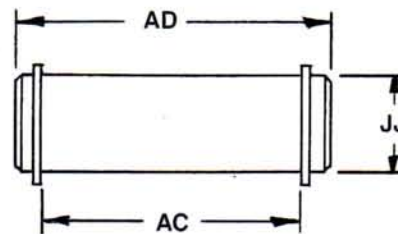

## EYE MOUNT

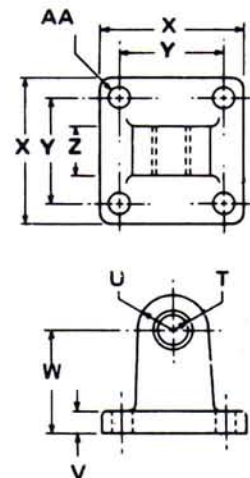

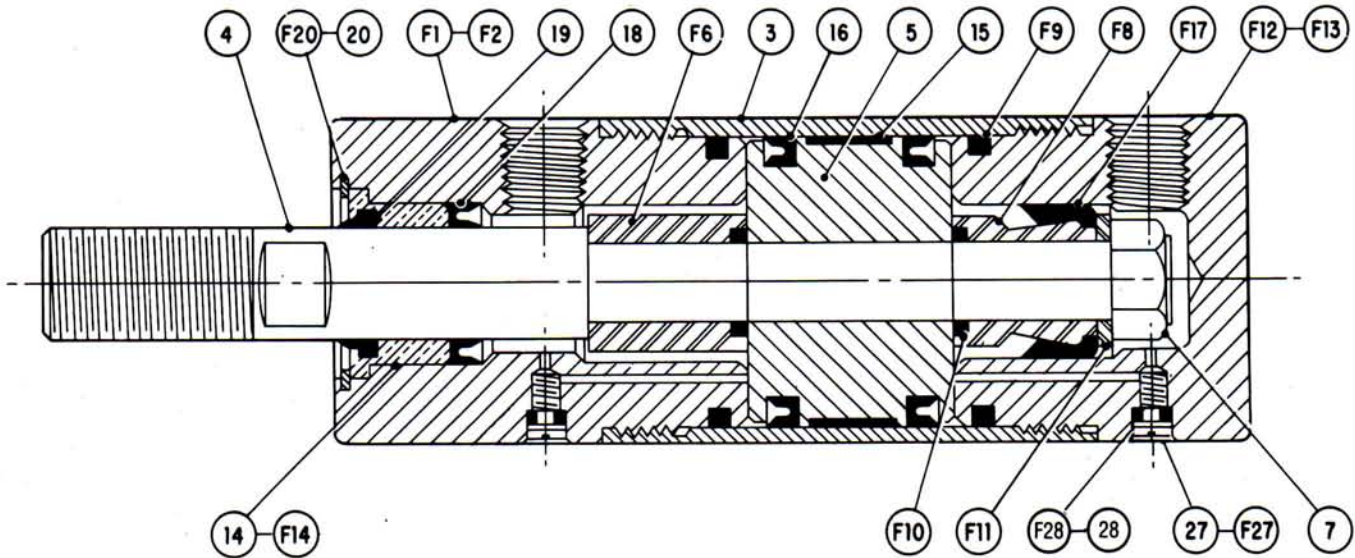

**PARTS LIST**

P/N	DESCRIPTION	QTY.
F-1	FRONT HEAD (STANDARD) WITH P/N 27 & 28	1
F-2	FRONT HEAD (NOSE MOUNT) WITH P/N 27 & 28	1
3	CYLINDER TUBE	1
4	PISTON ROD	1
5	PISTON	1
F-6	STANDARD SPACER	2
7	PISTON NUT	1
F-8	CUSHION SPACER	1*
F-9	TUBE SEAL "O" RING	2
F-10	PISTON ROD "O" RING	2
F-11	WASHER	1*
F-12	REAR CAP (STANDARD) WITH P/N 27 & 28	1
F-13	REAR CAP (CLEVIS MOUNT) WITH PIN & P/N 27 & 28	1
14	ROD BUSHING (STANDARD)	1
F-14	ROD BUSHING (R240 NOSE MOUNT ONLY)	1
15	PISTON BEARING STRIP	1
16	PISTON SEAL	2
F-17	CUSHION CUP	1*
18	ROD SEAL (STANDARD)	1
18-PP	ROD SEAL (HYDRAULIC)	1
19	ROD WIPER	1
20	BUSHING RETAINING RING (STANDARD)	1
F-20	BUSHING RETAINING RING (R240 NOSE MOUNT ONLY)	1
27	CUSHION SCREW (STANDARD)	2
F-27	CUSHION SCREW (R700 ONLY)	2
28	CUSHION SCREW "O" RING (STANDARD)	2
F-28	CUSHION SCREW "O" RING (R700 ONLY)	2

**NOTE:** \*Refers to amount per cushion

**REPAIR KITS**

Repair kits containing all wearable replacement parts are available.

Please specify cylinder model, single or double ended, type of cushion, air or hydraulic operated and any options which affect repair kit.

The R240 nose mount cylinder requires a special size rod bushing and bushing retaining ring. Please specify nose mount when ordering this model repair kit.

**STANDARD REPAIR KIT**

**CONTAINS:**

P/N F-9, F-10, 14, 15, 16, 18, 19, 20 & 28.

**CUSHION REPAIR KIT CONTAINS:**

Standard repair kit plus P/N F-17.



# SERIES AP



**Process Control Device  
Utilized with Series B & J Cylinders  
2 1/2" - 8" Bores  
250 PSI Pneumatic**

C31 ACTUATOR POSITIONER

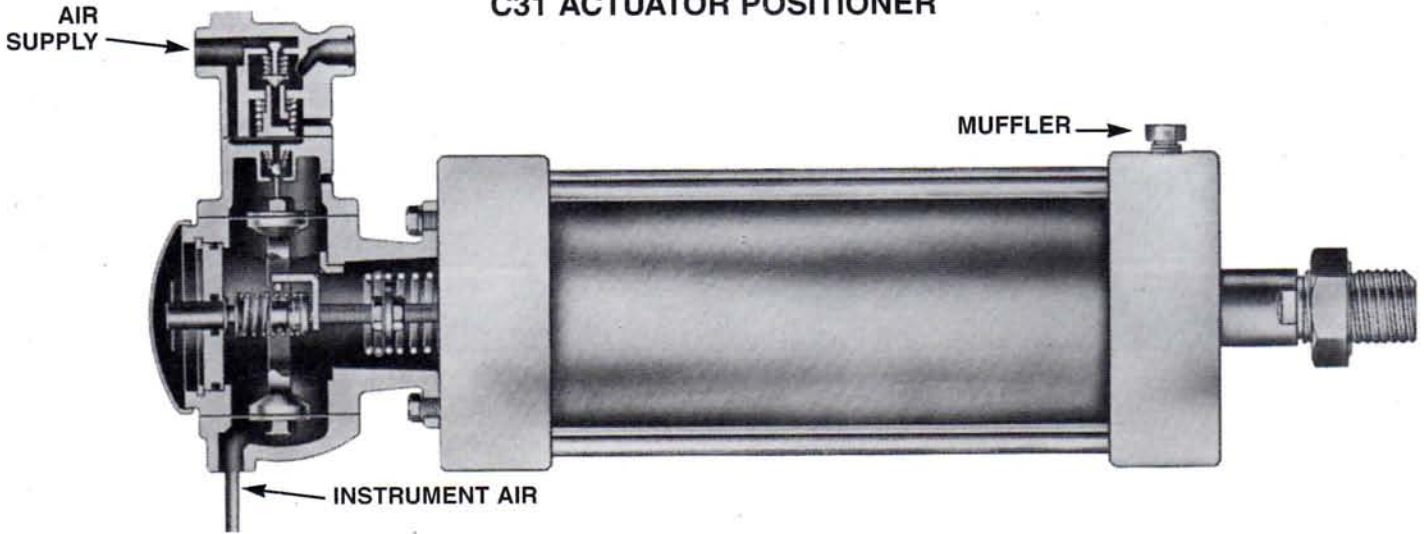

# ACTUATOR POSITIONER FOR AIR CYLINDERS

*Ideal for the positioning of:*

1. Butterfly Valves
2. Dampers
3. Louvers
4. Gas and Oil Burner Valves
5. Blast Gates
6. Variable Pitch Fans
7. Metering Pumps
8. Speed Change

Positioner cylinder operating pressure: 20 to 100 PSI air only.

**Standard:** Instrument span .....12 PSI  
 Range .....3 PSI to 15 PSI  
 Consult factory for other options.

**Repeatability:** 1/8" to 1/4" on all positioners.

**DO NOT ROTATE PISTON ROD.** This will affect factory setting.

**Mounting Options:** Flush mount (except Model B490)  
 Front face mount  
 Front flange mount (from Series B & J)  
 Front, rear or center trunnion (from Series B & J)  
 Accessories (from Series B & J)

## SERIES AP ACTUATOR POSITIONER DIMENSIONS

MODEL	BORE	ROD DIA.	EXTEND POWER MULTIPLE	RETRACT POWER MULTIPLE	A	B	C	D	* E	* F	* G
B490	2½	¾	4.91	4.47	5 <sup>5</sup> / <sub>64</sub>	2¼	¾-10 x 1½	2.203	2 <sup>7</sup> / <sub>8</sub>	2 <sup>7</sup> / <sub>8</sub>	5/16-24 x 9/16
B700	3	¾	7.07	6.62	5 <sup>5</sup> / <sub>64</sub>	2¼	¾-10 x 1½	2.625	3 <sup>3</sup> / <sub>8</sub>	3 <sup>3</sup> / <sub>8</sub>	5/16-24 x 9/16
B960	3½	1	9.62	8.84	6 <sup>35</sup> / <sub>64</sub>	2 <sup>5</sup> / <sub>8</sub>	1-8 x 1 <sup>5</sup> / <sub>8</sub>	3.219	4	4 <sup>1</sup> / <sub>8</sub>	3/8-24 x 1 <sup>1</sup> / <sub>16</sub>
B1600	4½	1	15.90	15.12	6 <sup>35</sup> / <sub>64</sub>	2 <sup>5</sup> / <sub>8</sub>	1-8 x 1 <sup>5</sup> / <sub>8</sub>	4.031	5	5 <sup>1</sup> / <sub>8</sub>	½-20 x 1 <sup>1</sup> / <sub>16</sub>
B1960	5	1	19.63	18.85	6 <sup>5</sup> / <sub>64</sub>	2 <sup>5</sup> / <sub>8</sub>	1-8 x 1 <sup>5</sup> / <sub>8</sub>	4.100	5½	5½	½-20 x 1 <sup>1</sup> / <sub>16</sub>
J2800	6	1½	28.27	26.50	7¾	2½	1¼-12x1 <sup>5</sup> / <sub>8</sub>	4.875	6½	6½	½-20 x 5/8
J5000	8	1½	50.26	48.50	7¾	2½	1¼-12x1 <sup>5</sup> / <sub>8</sub>	6.440	8½	8½	5/8-18 x ¾

\*Dimensions shown for model B490 are for front head only. Back cap is 3¾" diameter.



## J21 OR J22 ACTUATOR POSITIONER

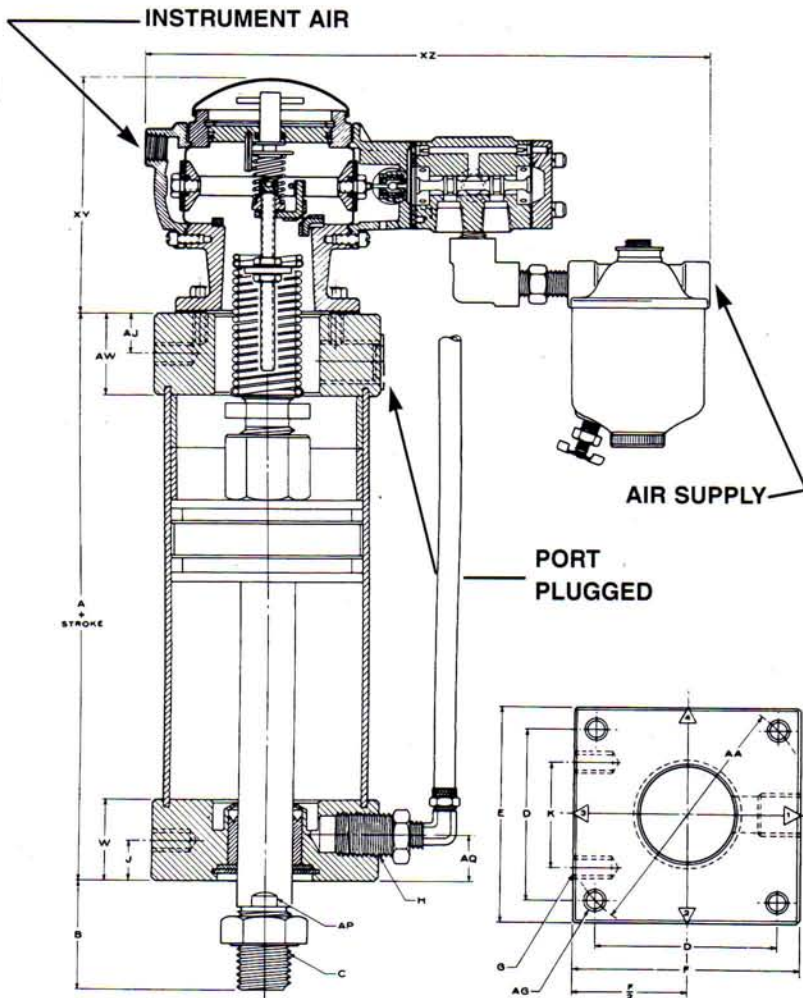

NOTE: All dimensions apply to J21 or J22.  
All but A & XZ dimensions apply to the C31. Consult factory for C31 dimensions.

### POSITIONER SPECIFICATIONS

The C31 Positioner is a single acting, spring return. The piston rod extends on instrument air increase. A spring on the piston rod end causes the piston rod to retract as instrument air is decreased or lost. If air supply is lost, piston rod will retract. The extending force is diminished by the spring force; therefore, it is impossible to get 100% force in either direction.

MODEL	SPRING FORCES	AVAILABLE STROKES
B490	Consult Factory	2" - 10"
B700	Not Available	
B960	Consult Factory	2" - 10"
B1600	Consult Factory	2" - 10"
B1960	Not Available	
J2800	Consult Factory	2" - 10"
J5000	Consult Factory	6" - 14"

The J21 or J22 Positioners are double acting. The J21 starts out with the piston rod fully retracted and extends on instrument air increase. The J22 starts out with the piston rod fully extended and retracts on instrument air increase. 100% force in both directions is possible with the J21 or J22.

Standard stroke lengths are 2" through 14" in 1" increments.

*H NPT	J	* K	W	AA	AG	AJ	AP	AQ	AR	AW	XY	XZ
3/8	19/32	1 1/4	1 3/16	3.115	5/16-24 x 1/2	—	5/8	1 1/16	—	1 3/16	4 9/16	10 1/8
3/8	19/32	1 1/4	1 3/16	3.712	5/16-24 x 1/2	19/32	5/8	1 1/16	1 1/16	1 3/16	4 9/16	10 1/8
1/2	23/32	1 27/32	1 1/2	4.552	3/8-24 x 1 1/16	23/32	7/8	2 7/32	2 7/32	1 1/2	4 9/16	10 1/8
1/2	23/32	2 1/2	1 1/2	5.701	1/2-20 x 1 1/16	23/32	7/8	2 7/32	2 7/32	1 1/2	4 9/16	10 1/8
1/2	3/4	2 11/16	1 1/2	5.798	1/2-20 x 1 1/16	3/4	7/8	2 7/32	2 7/32	1 1/2	4 9/16	10 1/8
3/4	1 1/4	3 1/4	2	6.894	1/2-20 x 1/2	3/4	1 1/4	1 1/4	3/4	1 1/2	4 9/16	10 1/8
3/4	1 1/4	4 1/2	2	9.108	5/8-18 x 1/2	3/4	1 1/4	1 1/4	3/4	1 1/2	4 9/16	10 1/8

**C31 SPECIFICATIONS**

**J21 OR J22 SPECIFICATIONS**

**Supply Pressure Effect:** Less than 0.15% per PSI

**Supply Pressure Effect:** Less than 0.15% per PSI.

**Ambient Temperature Range:** -20°F to +150°F

**Ambient Temperature Range:** -20°F to +150°F

**Flow Capacity (Dynamic):** Up to 5.0 SCFM in either direction with a 100 PSI supply.

**Flow Capacity (Dynamic):** Up to 5.0 SCFM in either direction with a 100 PSI supply.

**Air Consumption (Static):** 0.3 SCFM with 40 PSI supply pressure.

**Air Consumption (Static):** 1.0 SCFM with 40 PSI supply pressure.

**Air Supply:** 20 PSI to 100 PSI

**Air Supply:** 20 PSI to 100 PSI

**Adjustment:** Zero adjust is external and can be made without tools.

**Adjustment:** Zero adjust is external and can be made without tools.

**STANDARD REPAIR KITS CAN BE USED TO REPAIR J21 OR J22 CYLINDERS. C31 CYLINDERS SHOULD BE REPAIRED AT THE FACTORY BECAUSE OF HIGH COMPRESSION SPRING INSIDE.**

**REPLACEMENT C31, J21 OR J22 POSITIONERS, RANGE SPRING OR RANGE SPRING ASSEMBLIES CAN BE PURCHASED. CONSULT FACTORY FOR OTHER PARTS.**

**ORDERING INSTRUCTIONS FOR SERIES AP CYLINDERS**

4      B490   X      12      J21      Style #1 - - -

Quantity ———— ↑

Model ———— ↑

Stroke ———— ↑

Type of Positioner ———— ↑

Rod End Style ———— ↑

Style #1 Standard Full Male Thread (B Series)  
 Style #2 Standard Small Male Thread (J Series)  
 Style #3 Optional Female Thread - This Thread and all Optional Rod Ends, Please Specify Thread, Length or Depth, Plus "B" Dimension

Options ———— ↑

416SS Rod  
 303SS Rod, Tie Rods, & Nuts  
 Magno Piston (Required for Reed Switch Operation)  
 Hard Coat (Head, Cap, & Piston)  
 Complete Corrosion Resistance (Hard Coat Option, Plus 303SS Rod, Tie Rods, & Nuts)  
 Metallic Rod Wiper (Do not use with stainless steel rod.)

Mounting Options and Accessories ———— ↑



# SERIES T



**Air-Oil Tank**  
**2 1/2" - 8" Bores**  
**250 PSI Hydraulic**  
**NFPA Porting**

# SERIES T AIR-OIL TANKS

Advance Automation Air-Oil Tanks offer a way of using workplace air pressure and converting it into hydraulic pressure. The hydraulic pressure is the same as the air pressure supplied.

Air-Oil Tanks are mainly used in slow speed applications where smooth piston rod travel is required.

Advance Automation Air-Oil Tanks use aluminum head, cap and tube. They feature baffles on the top and bottom, shatterproof sight gauge and flush-type fill and drain plugs. The operating pressure is 250 PSI maximum.

## TANK SELECTION

1. Calculate work cylinder volume in cubic inches, Area x Stroke = Volume.
2. Select the proper tank bore and height from the usable oil capacity chart. Since there are usually several combinations, select the one having a capacity closest to but greater than your volume requirements.
3. Base your selection on a combination of economics, space requirements and port size.

## EXAMPLE

1. Work cylinder: B1600 X 10  
Area of 4½" bore = 15.9 square inches x 10" Stroke = 159 cubic inches Volume
2. Possible combinations:  
 T960 x 20" Tank Height = 163 cubic inches  
 T1600 x 13" Tank Height = 159 cubic inches  
 T1960 x 12" Tank Height = 163 cubic inches  
 T2800 x 10" Tank Height = 183 cubic inches  
 T5000 x 7" Tank Height = 195 cubic inches

MODEL	TANK BORE IN INCHES	TANK HEIGHT WITH							
		4	5	6	7	8	9	10	
T490	2½	5	10	15	20	25	29	34	
T960	3½	10	19	29	38	48	58	67	
T1600	4½	16	32	48	64	80	95	111	
T1960	5	20	39	57	76	93	110	127	
T2800	6	28	55	82	110	135	158	183	
T5000	8	50	98	146	195	239	280	324	



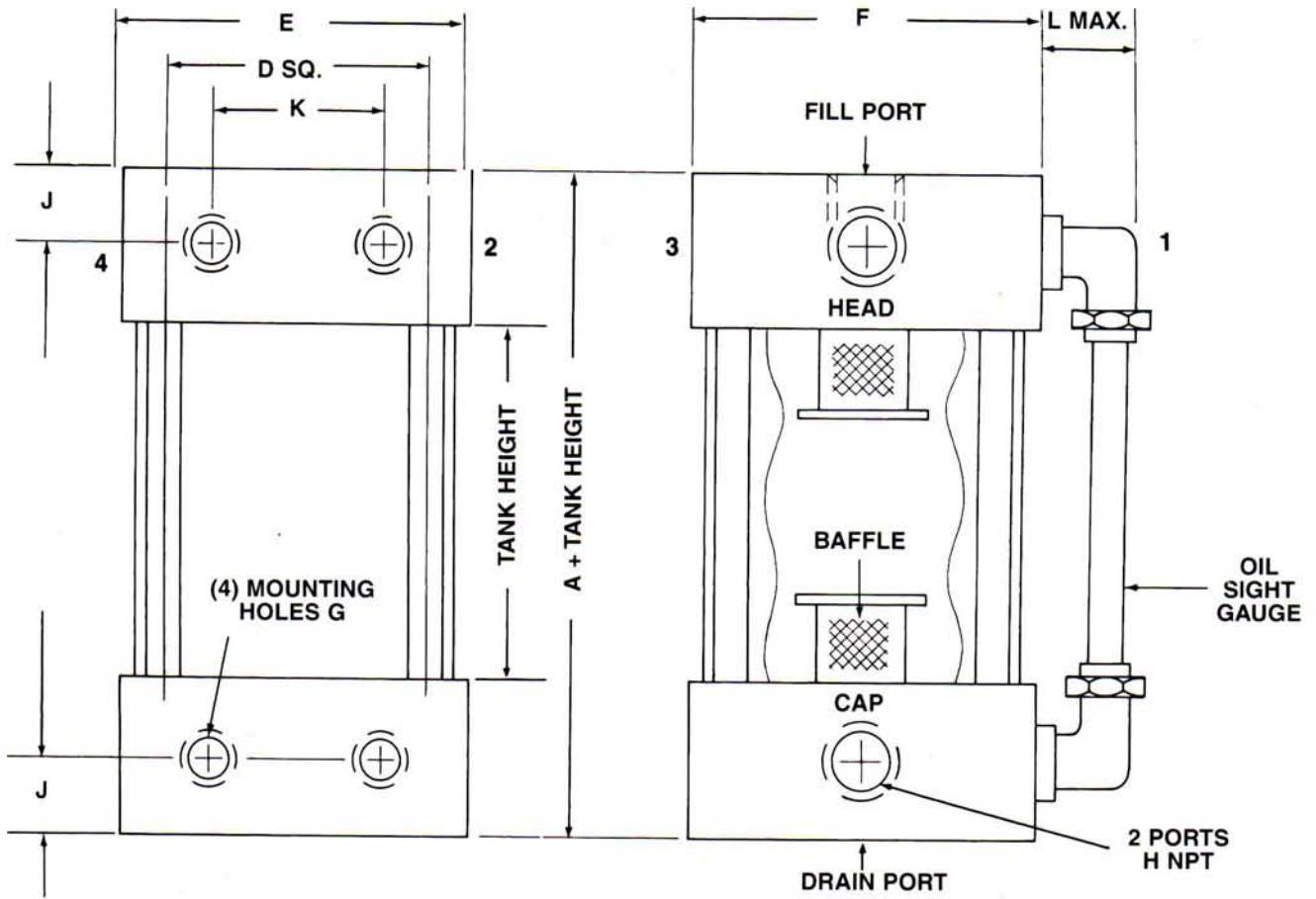

MODEL	BORE	AIR-OIL TANK DIMENSIONS								
		A	D	E	F	G	H	J	K	L
T490	2½	2¾	2.203	2⅞	2⅞	⅝ - 24 x ⅞	⅜	19/32	1¼	1⅞
T960	3½	3	3.219	4	4⅞	¾ - 24 x 1⅞	½	23/32	127/32	1⅞
T1600	4½	3	4.031	5	5⅞	½ - 20 x 1⅞	½	23/32	2½	1⅞
T1960	5	3	4.100	5½	5½	½ - 20 x 1⅞	½	¾	211/16	1⅞
T2800	6	3	4.875	6½	6½	½ - 20 x ⅝	¾	¾	3¼	1⅞
T5000	8	3	6.440	8½	8½	⅝ - 18 x ¾	¾	¾	4½	1⅞

**USABLE OIL CAPACITY - CUBIC INCHES**

	11	12	13	14	15	16	17	18	19	20
	39	44	49	54	59	64	69	74	78	83
	77	86	96	106	115	125	134	144	154	163
	127	143	159	175	191	207	239	254	270	302
	143	163	181	198	215	232	250	268	304	337
	206	234	260	284	309	334	359	386	411	437
	365	414	461	504	547	592	637	684	729	774

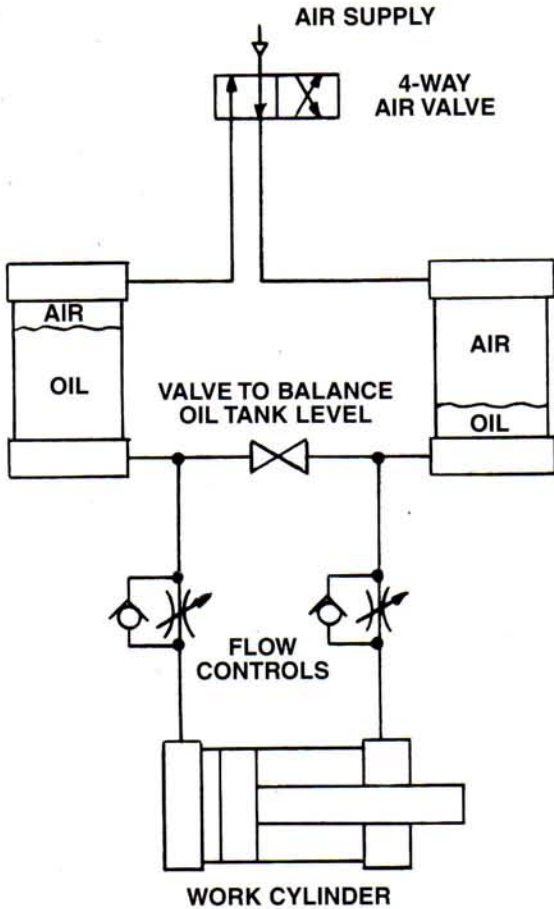

## DUAL TANK AIR-OIL SYSTEM

1. Flow controls are recommended to limit the fluid velocity.
2. Mount Air-Oil Tanks vertically at the highest point in the system. This allows self-bleeding of the tank.

### ORDERING INSTRUCTIONS FOR SERIES T AIR-OIL TANKS

Quantity 4

Model T960

Tank Height X

Options 10 - - -

Mounting Options \_\_\_\_\_

Hard Coat (Head & Cap)  
303SS Tie Rods & Nuts

Side Tapped Standard  
Flange Mount (From Series B & J)  
End Lug Mount (From Series B & J)

Sight Gauge at Position #1, Ports at Position #2 and Side Tapped at Position #3 are standard in all Air-Oil Tanks.



# SERIES LS

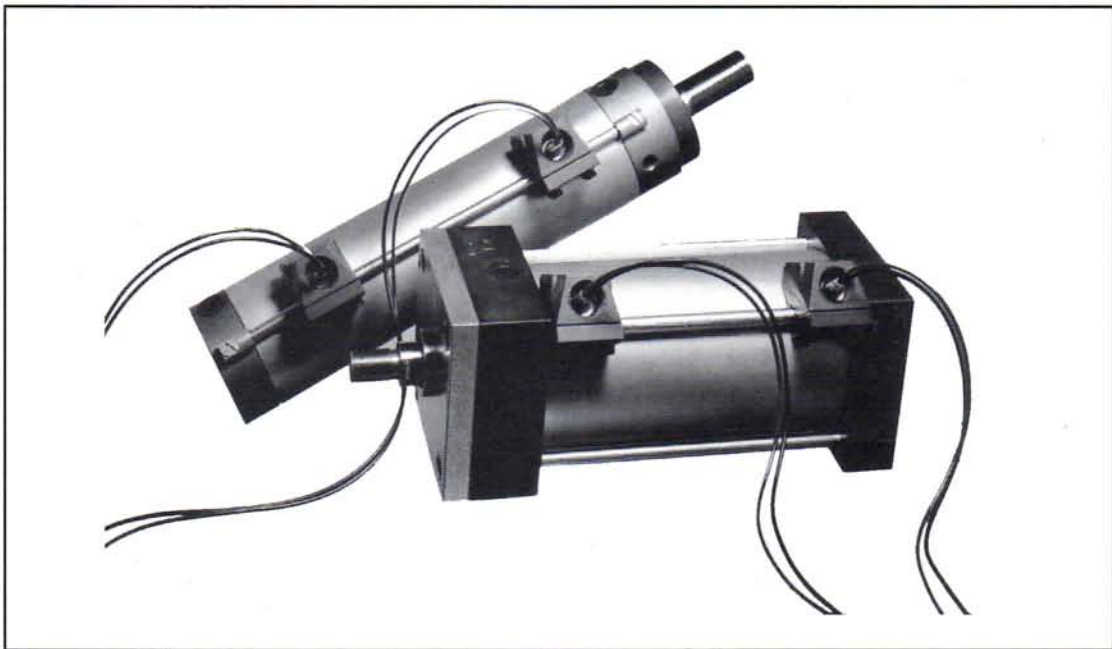

**Originators of Magno Reed Limit Switches  
UL Listed Models  
Indicator Light Feature**

SWITCH MODEL	SWITCH POSITION	MOUNTING
<b>LS10A</b>	NO — Normally Open	L — Left Hand or R — Right Hand

SWITCH MODEL	SWITCH POSITION	MOUNTING
<b>LS10 OR LS20</b>	NO — Normally Open OR NC — Normally Closed	L — Left Hand or R — Right Hand

SWITCH MODEL	SWITCH POSITION	MOUNTING
<b>LS30</b>	NO — Normally Open AND NC — Normally Closed	L — Left Hand or R — Right Hand

SWITCH MODEL	SWITCH POSITION	MOUNTING
<b>LS11 OR LS21</b>	NO — Normally Open	L — Left Hand or R — Right Hand

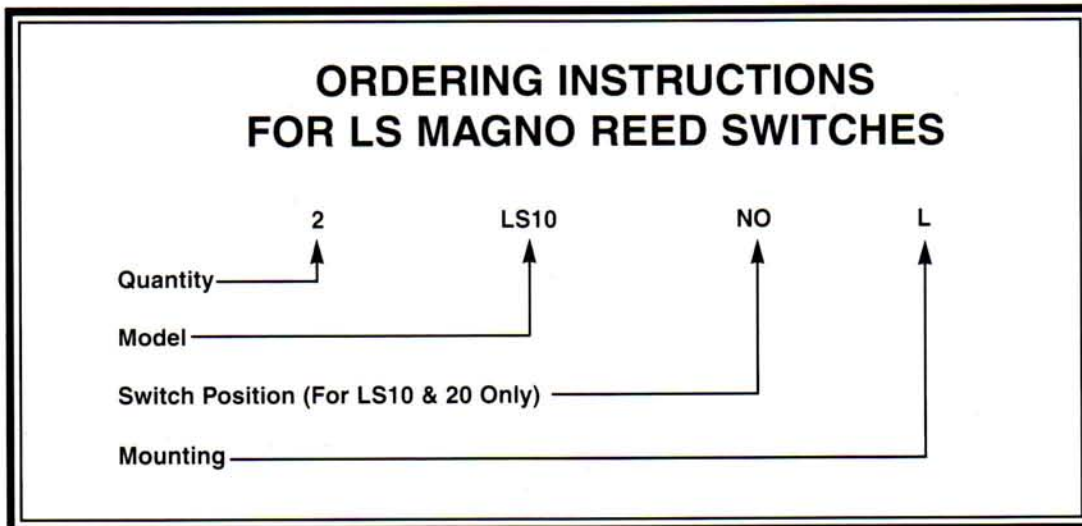

When ordering switch only, specify cylinder bore size or model.  
 Mounting brackets change: 1¼"-4½" and 5"-8" bore.  
 Model B120 cylinders require 303SS rod and tie rods for proper switch actuation.



# SWITCH RATINGS

## Do Not Exceed Switch Rating.

If you are not sure of your circuitry current ratings, we recommend you use the LS20.

## Caution

Limit switches can be destroyed by a very brief direct connection across line voltage, such as brushing a wire against conduit. **DO NOT CONNECT WITH A LIVE CIRCUIT.** Turn on power only after you are certain that the switch is connected in series with a properly rated load.

## SWITCH TESTING

All switches have been factory tested. If field testing is desired, the testing device must coincide with all switch data to prevent switch failures due to testing.

## FACTS

**LS10A & 10** — These switches have reeds only. To protect against contact deterioration, a contact protection circuit may be required. Consult ratings on page 54.

**LS20** — This switch has the necessary electrical components built in to allow direct wiring into the majority of circuits without the aid of additional resistors and capacitors. Consult ratings on page 54.

LS20 switches include a triac and will not operate on D.C. Switch will appear to malfunction if tested with a D.C. device such as a V.O.M. or continuity tester. For proper switch actuation, .05 AMP minimum current load required.

**LS30** — This switch contains a reed only with 3 leads. They are green (NO - Normally Open), red (NC - Normally Closed) and black (common). To protect against contact deterioration, a contact protection circuit may be required. Consult ratings on page 54.

### SAMPLE CIRCUIT

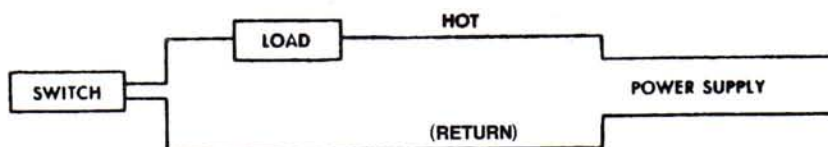

Listed

## FOR LS10, 20 & 30

Industrial Control Equipment for Hazardous Locations

Class I	Groups A, B, C, D	Div. 2
Class II	Groups F, G	Div. 2
Class III	Div. 2	

(LS10A, 11 & 21 are not UL Listed.)

# SWITCH SELECTION FOR LS10A, 10, 20 & 30

## LIGHT DUTY LS10A, 10 & 30

VOLTAGE A.C. or D.C.	RATING*
0-24 VDC 0-24 VAC	.50A
0-120 VAC	.85A

\*Maximum rating in rush and holding.

- UL Listed (Not LS10A)
- 2 Millisecond Response
- Easily Adjustable
- Hard Coated Aluminum Housing with 1/2" conduit outlet (Not LS10A)
- 36" Standard Leads (48" LS30)
- Vibration and Shock Rating in excess of 50 G's
- Oil and Water Resistant

**NOTE:** For various loads encountered, consult page 54.

## HEAVY DUTY LS20 SWITCHES

VOLTAGE RATING	TEMPERATURE DERATING SCALE	
	TEMPERATURE	CURRENT RATING ANY TYPE LOAD*
24 VAC TO 120 VAC	80°F	1 AMP
	100°F	.83 AMP
	120°F	.66 AMP
	140°F	.49 AMP
	160°F	.32 AMP
	180°F	.16 AMP
	200°F	0

\*Ratings shown are holding current ratings. In rush can be equal to 10 times the holding current. Minimum current load, .05 AMP for proper switch actuation.

UL Rating                      24-120 VAC                      .50A

# INSTALLATION

VOLTAGE CONTACT	0-24VDC 0-.50 A	0-24VAC 0-.50 A	0-120VAC 0-.085 A	24-120VAC .05-.50 A	MOUNTING POSITIONS
SPST - Normally Open	LS10AL or LS10NOL			LS20NOL	A, B, E, or F
	LS10AR or LS10NOR			LS20NOR	B, C, D, or E
SPST - Normally Closed	LS10NCL			LS20NCL	A or B
	LS10NCR			LS20NCR	B or C
SPDT	LS30L			N/A	A, B, E, or F
	LS30R			N/A	B, C, D, or E

When sensing end of stroke, switch must be located precisely for magnet to actuate reed contact points.

LS10A MOUNTING POSITIONS

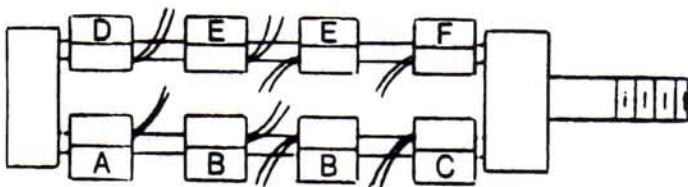

LS10, LS20, LS30 MOUNTING POSITIONS

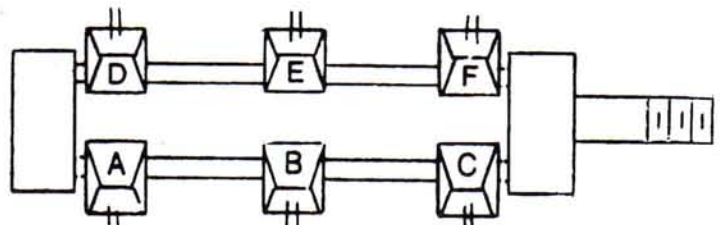



# LS11 & LS21 INDICATOR LIGHT REED SWITCH

In addition to all the industry leading features and benefits of the popular LS10 and LS20 switches, these models incorporate lights to show the on/off status of the switch.

**LS11** A two (2) wire device intended for lower level D.C. voltages. The LS11 is excellent for use with solid state logic systems and programmable controllers that require 12 to 30V D.C. inputs. A green L.E.D. provides the illumination (see specifications and wiring).

**LS21** A three (3) wire device intended for 110-120 A.C. operation at up to 1.00 AMP. An orange neon bulb provides the illumination (see specifications and wiring).

**MODELS AVAILABLE: These are not UL Listed.**

LS11L  
LS11R

LS21L  
LS21R

## LS11, 21 HOUSING

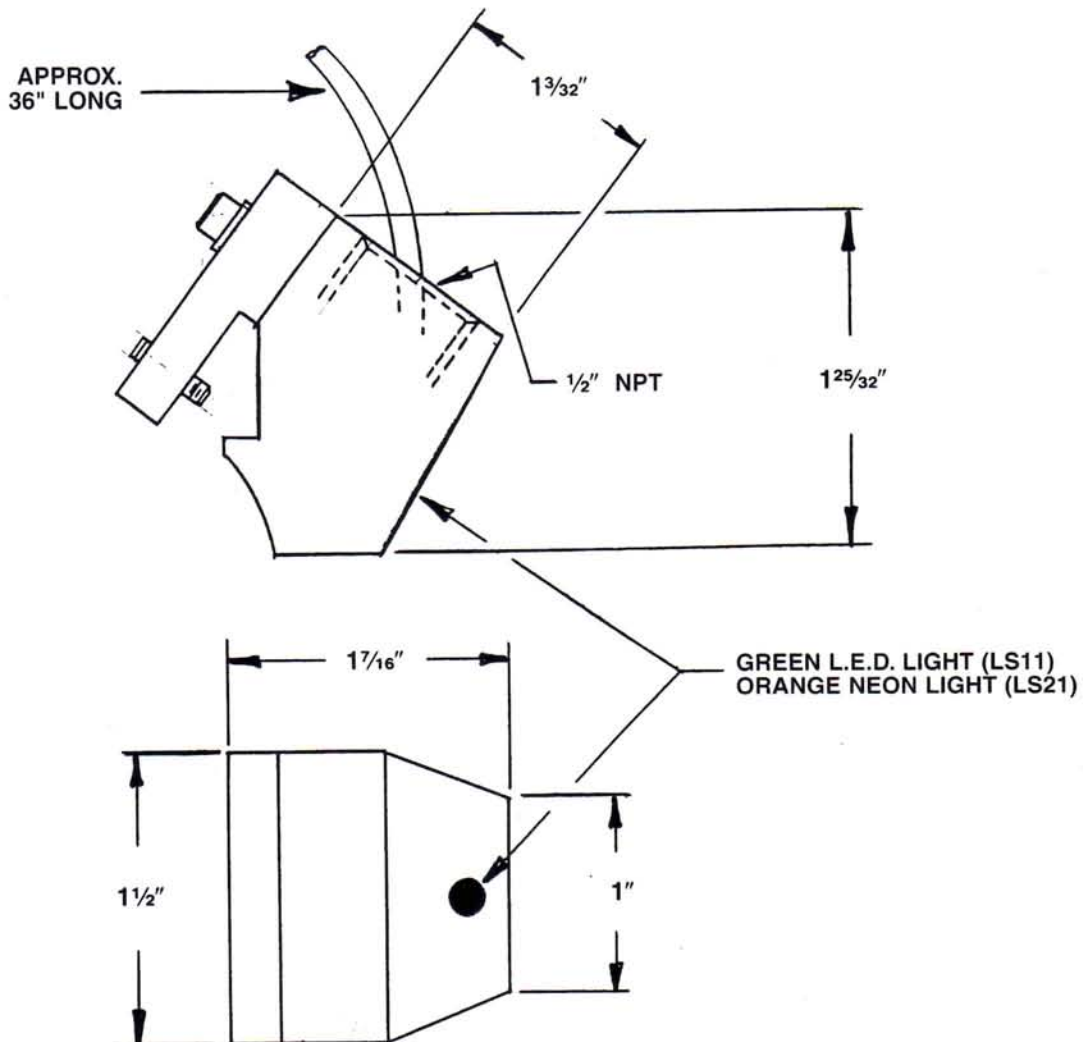

# SPECIFICATIONS FOR LS11 & LS21

**NOTE:** To find power in watts, simply multiply current times voltage (i.e.: Power = Volts x Amps)

	LS11		LS21
	D.C.	*A.C.	A.C. ONLY
MAXIMUM VOLTAGE	100	120	135
MAXIMUM CURRENT (AMPS)	.300	.200	1.00
MINIMUM VOLTAGE	10	12	90
MINIMUM CURRENT (AMPS)	.005	.050	.050
MAXIMUM POWER (WATTS)	10	10	100

\*The LS11 was designed primarily for D.C. applications; however, it can be used on A.C. voltages if a lower light output can be tolerated.

## WIRING DIAGRAMS

### LS11

#### SAMPLE CIRCUIT

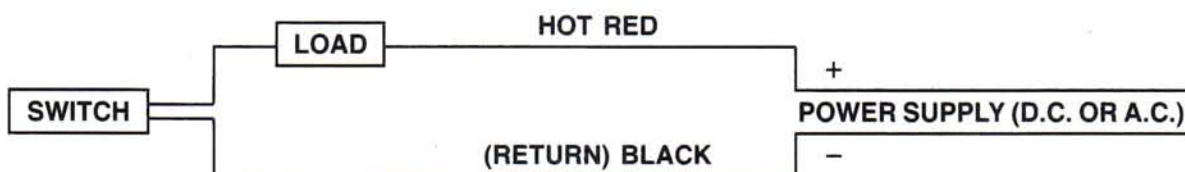

- NOTE:** 1) On D.C. circuits observe polarity (red is plus [+], black is minus [-]). No damage will occur if reversed, but the light will not operate.
- 2) On A.C. circuits there are no polarity requirements. The light output will be less on A.C. voltages than on D.C. voltages.

### LS21

#### SAMPLE CIRCUIT

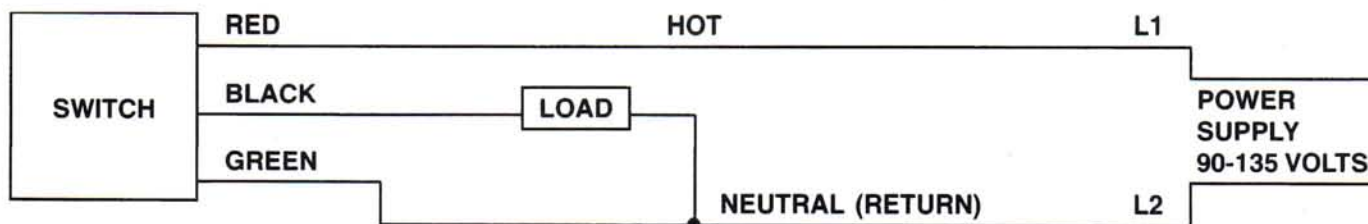

Protection circuits (page 54) and installation instructions (page 51) are identical. Example:

**LS11 Same as LS10NO**  
**LS21 Same as LS20NO**

See temperature derating scale on page 51 for LS21 ratings at higher temperature.



# CONTACT PROTECTION CIRCUITS

There are four types of loads which could be encountered:

A. **RESISTIVE** — For resistive loads a contact protection circuit is not required.

B. **INDUCTIVE** — An inductive load, such as a relay, solenoid, or counter, will cause an inverse voltage when the contacts are opened and contact deterioration may result. In order to prevent this, contact protection circuits 1 or 2 may be used.

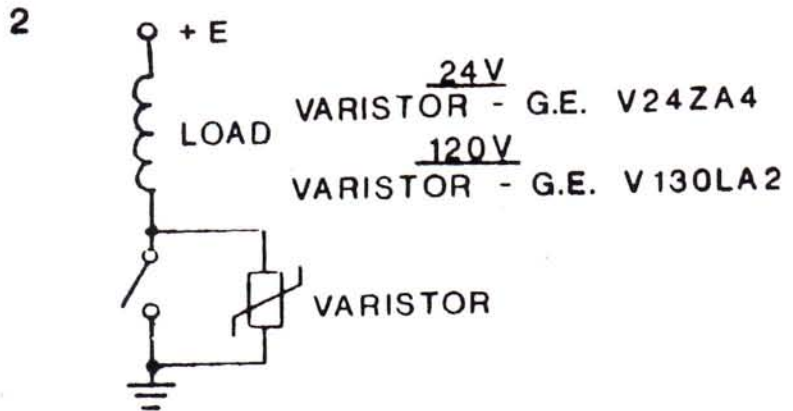
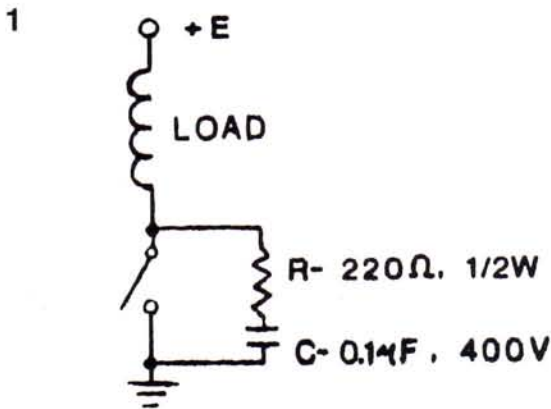

C. **INCANDESCENT** — Incandescent lamp loads cause high inrush current resulting in short contact life. To prevent this, contact protection circuit 3 or 4 may be used.

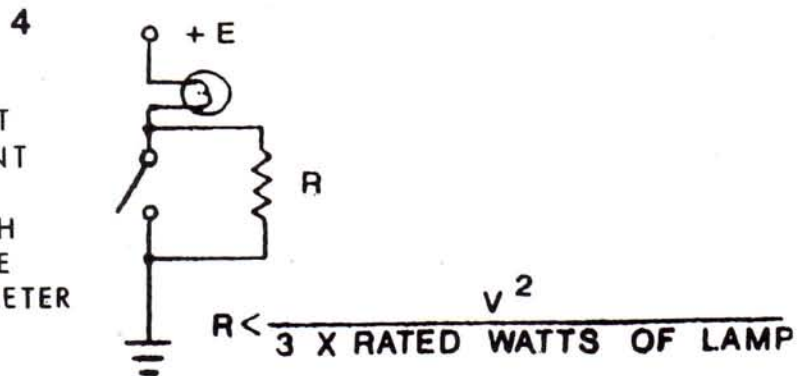
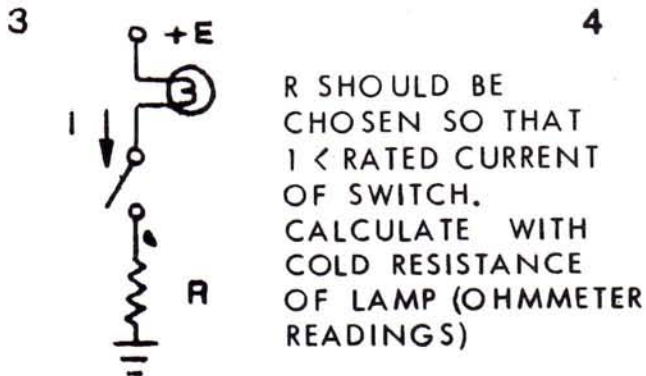

D. **CAPACITIVE** — Capacitive loads are seldom encountered. Consult the factory for contact protection circuit.

# ARC LINEAR ALIGNMENT COUPLER



**Extend the service life of Advance Automation cylinders by installing an ARC LINEAR ALIGNMENT COUPLER to compensate for misalignment.**

**An alignment coupler can reduce cylinder and component wear to save you money.**

**Sixteen thread sizes, both fine and coarse, are available.**



# SPECIFICATIONS

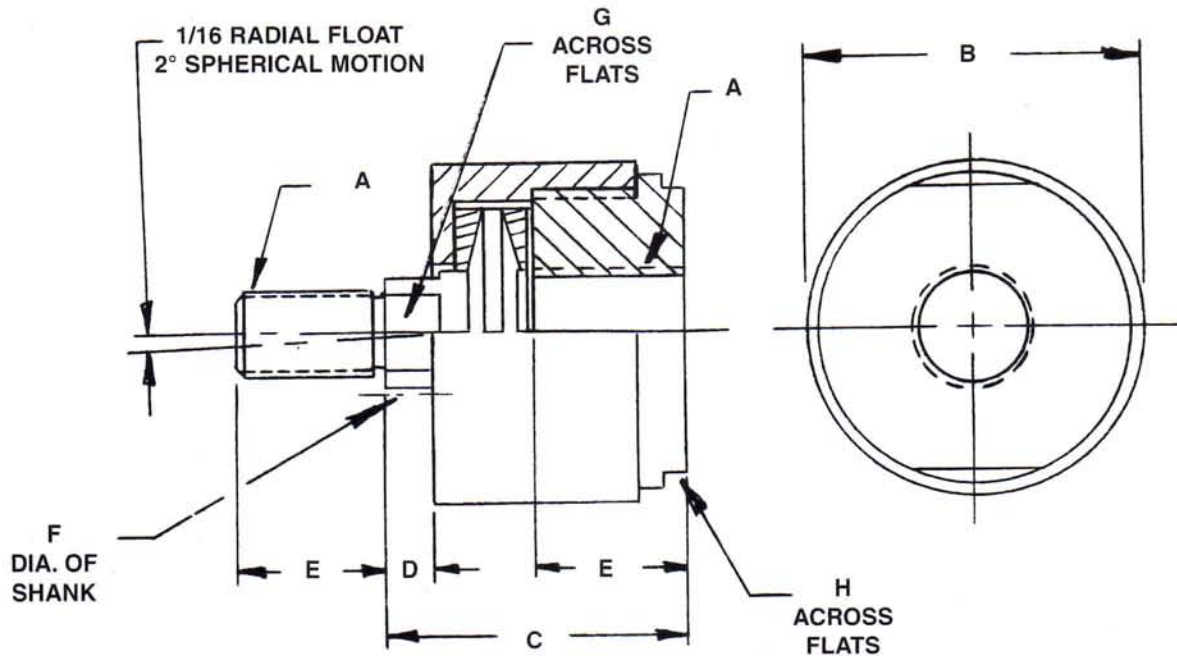

MODEL NUMBER	A TH'D	B	C	D	E	F	G	H	MAX. PULL AT YIELD
ARC-3125F	5/16-24	7/8	1 1/4	1/4	5/8	5/16	1/4	3/4	8,300
ARC-375F	3/8-24	7/8	1 1/4	1/4	5/8	5/16	5/16	3/4	8,300
ARC-375C	3/8-16	7/8	1 1/4	1/4	5/8	5/16	5/16	3/4	5,000
ARC-437F	7/16-20	1 1/4	2	1/2	3/4	5/8	1/2	1	10,000
ARC-500F	1/2-20	1 1/4	2	1/2	3/4	5/8	1/2	1	14,000
ARC-500C	1/2-13	1 1/4	2	1/2	3/4	5/8	1/2	1	14,000
ARC-625F	5/8-18	1 1/4	2	1/2	3/4	5/8	1/2	1	19,000
ARC-750F	3/4-16	1 3/4	2 5/16	1/2	1 1/8	31/32	13/16	1 1/2	34,000
ARC-750C	3/4-10	1 3/4	2 5/16	1/2	1 1/8	31/32	13/16	1 1/2	34,000
ARC-875F	7/8-14	1 3/4	2 5/16	1/2	1 1/8	31/32	13/16	1 1/2	39,000
ARC-1000F	1-14	2 1/2	2 15/16	1/2	1 5/8	1 3/8	1 5/32	2 1/4	64,000
ARC-1000C	1-8	2 1/2	2 15/16	1/2	1 5/8	1 3/8	1 5/32	2 1/4	64,000
ARC-1250F	1 1/4-12	2 1/2	2 15/16	1/2	1 5/8	1 3/8	1 5/32	2 1/4	78,000
ARC-1375F	1 3/8-12	2 1/2	2 15/16	1/2	1 5/8	1 3/8	1 5/32	2 1/4	78,000
ARC-1500F	1 1/2-12	3 1/4	4 3/8	13/16	2 1/4	1 3/4	1 1/2	3	134,000
ARC-1750F	1 3/4-12	3 1/4	4 3/8	13/16	2 1/4	1 3/4	1 1/2	3	134,000

NOTE: Use jam nut when piston rod has full threads.

Consult factory for other sizes or materials.



## Installation For Series I, B & J, and R Cylinders

**INSTALLATION:** Cylinder life is directly dependent on proper installation. Utilize an air line filter to free lines of dirt, chips, scale, pipe dope, and other contamination. Additionally, the air supply should not contain water.

Align the piston rod with the mating machine part, both in the extended and retracted position, while placing minimum side load on the cylinder. Not following this instruction will reduce service life and increase maintenance required on cylinder.

If the cylinder includes cushions, adjust the cushion screw (27) to the desired setting. High inertia and high velocity applications may require external flow controls to help increase back pressure.

### Maintenance for Series I

**MAINTENANCE:** Standard repair kits are available for convenient replacement of wearable parts (See Page 15). To replace rod bushing (14) and rod seal (18), remove retaining plate (20). Next, remove bushing and seal by pulling out piston rod (4), or if necessary, applying air pressure to front head port. When installing new parts, use care in passing them over threaded portion of piston rod. It may be necessary to seat rod seal (18) with a blunt instrument.

To replace piston seals (16), remove front head (2) by backing off flush tie rod nuts (13) with drag link socket. Then, remove piston rod and piston assembly from cylinder tube (3). Carefully stretch off elastic piston seals (16) for easy replacement. Hold bearing strip (15) in place (dull side out) and "rock" piston rod and piston assembly back into the cylinder tube. Replace both tube seal "O" rings (19). Reassemble in a vertical position, with blind end facing down. Apply equal torque when retightening tie rod nuts.

Avoid introducing any dirt or chips into the cylinder during repair operations, as well as damaging piston, piston rod, cylinder tube, and seals.

### Maintenance for Series B & J

**MAINTENANCE:** Standard repair kits are available for convenient replacement of wearable parts (See Page 32). To replace rod bushing (14) and rod seal (18), remove retaining ring (20) with needle nose pliers. Next, remove bushing and seal by pulling out piston rod (4), or if necessary, applying air pressure to front head port. When installing new parts, use care in passing them over threaded portion of piston rod. It may be necessary to seat rod seal (18) with a blunt instrument.

To replace piston seals (16), remove front head (2) by backing off flush tie rod nuts (13) with drag link socket. Then, remove piston rod and piston assembly from cylinder tube (3). Carefully stretch off elastic piston seals (16) for easy replacement. Hold bearing strip (15) in place (dull side out) and "rock" piston rod and piston assembly back into the cylinder tube. Replace both tube seals (21). Reassemble in a vertical position, with blind end facing down. Apply equal torque when retightening tie rod nuts.

Avoid introducing any dirt or chips into the cylinder during repair operations, as well as damaging piston, piston rod, cylinder tube, and seals.

### Maintenance for Series R

**MAINTENANCE:** Standard repair kits are available for convenient replacement of wearable parts (See Page 38). To replace rod bushing (14) and rod seal (18), remove retaining ring (20) with needle nose pliers. Next, remove bushing and seal by pulling out piston rod (4), or if necessary, applying air pressure to front head port. When installing new parts, use care in passing them over threaded portion of piston rod. It may be necessary to seat rod seal (18) with a blunt instrument.

To replace piston seals (16), remove front head (F-1 or F-2) using a spanner wrench on the hole supplied and turn the threaded head off the cylinder tube (3). Then, remove piston rod and piston assembly from cylinder tube (3). Carefully stretch off elastic piston seals (16) for easy replacement. Hold bearing strip (15) in place (dull side out) and "rock" piston rod and piston assembly back into the cylinder tube. Use care when passing piston through threaded barrel end. Replace tube seal "O" ring (F-9). Reassemble in vertical position, with blind end facing down. Replace head in the cylinder tube. When head is in place, replace rod seal, bushing, and snap ring.

Avoid introducing any dirt or chips into the cylinder during repair operations, as well as damaging piston, piston rod, cylinder tube, seals, and head.



**WARRANTY** — Advance Automation Company guarantees products of its manufacture against defective workmanship and/or material for a period of one year from the date of shipment. The guarantee is limited to repair or exchange at seller's option. No obligation is assumed for the repair or exchange of any product rendered defective or damaged through normal wear, or improper application, handling, or use. The guarantee is subject to Advance Automation Company being notified immediately upon discovery of any defective workmanship and/or material within said one year guarantee period, and the holding of the item for Advance Automation Company's inspection and disposition. No other liability, expressed or implied, is assumed by Advance Automation Company.

# **AAC** Advance Automation Company

3526 N. Elston Avenue, Chicago, Illinois 60618

Phone: 312/539-7633 • Fax: 312/539-7299

(Effective October 1996, new area code will be 773)



**NFPA**

*Solutions through motion technology*

MEMBER

