

WYKO

WYKO-TUFKON® CONVEYOR IDLERS

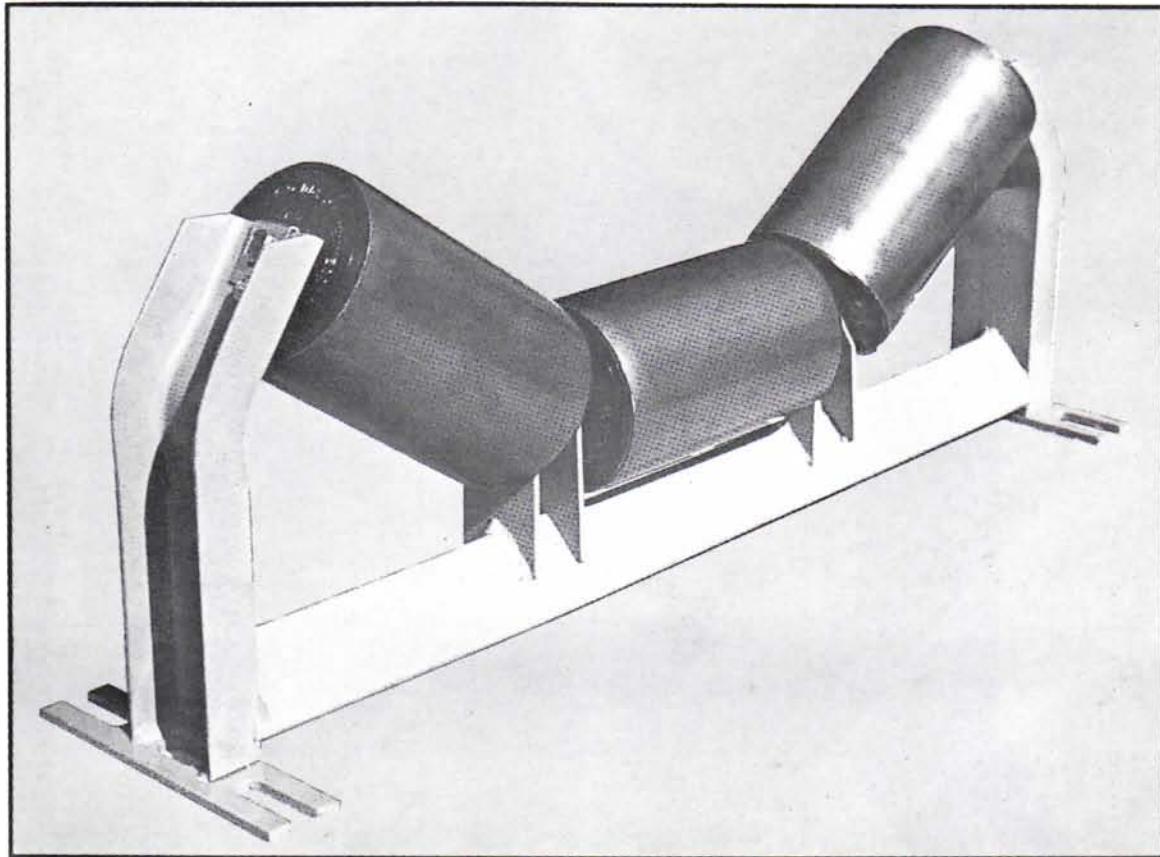

**BUILT TO HANDLE THE LOAD —
DESIGNED TO GIVE YOU THE
SERVICE YOU EXPECT**



MANUFACTURING AND SALES OFFICES:
P.O. BOX 130, GREENBACK, TENNESSEE 37742
PHONE (615) 856-2317 TELEX 6827104 FAX 615-856-2092

WYKO-TUFKON® "HT" SERIES STEEL ROLL IDLER

"THE CONVEYOR IDLER OF THE FUTURE"

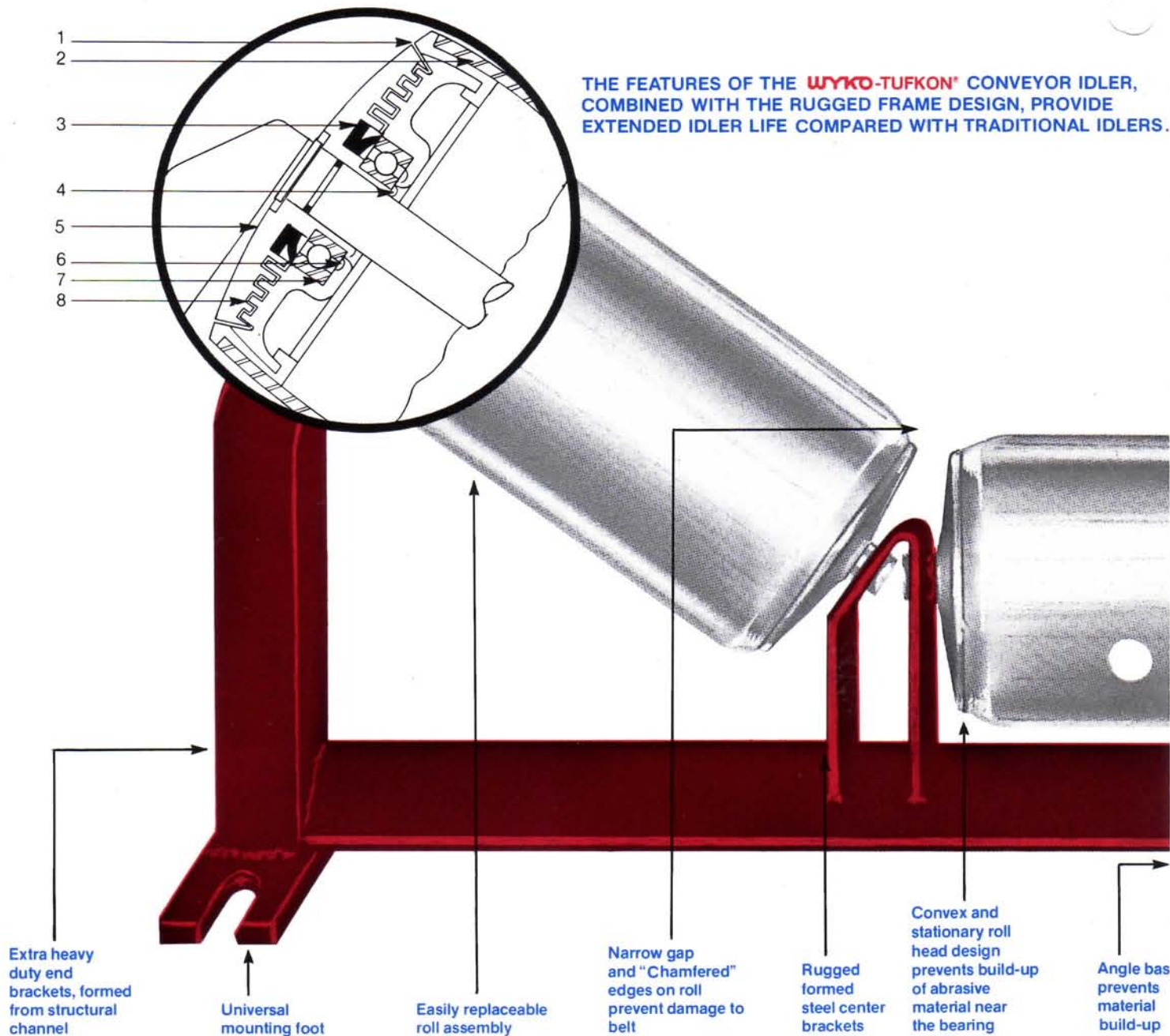

Patented design is tested and proven in a variety of applications.

1. Rotation of outer shell only maximizes centrifugal seal action at this point.
2. Chamfered roll shell protects belt and is chemically treated to prevent corrosion.
3. Patented low friction "V" type contact lip seal.
4. Full 1" diameter bearing is adapter mounted to a solid through shaft with a diameter of slightly greater than $\frac{3}{4}$ ".
5. Patented I. C. I. Maranyl non-corrosive, stationary end cap prevents possible locking of rolls due to chips, string, wire etc.
6. Inner side of bearing is sealed and grease packed.
7. Tests in contaminated conditions show the SKF seize-resistant idler bearing to have a 10 fold greater life when compared to conventional bearings.
8. Close clearance face type labyrinths.

WYKO-TUFKON® "HT" SERIES RUBBER IMPACT IDLER

"THE IMPACT IDLER BUILT TO TAKE THE LOAD"

WYKO-TUFKON® HEAVY DUTY RUBBER IMPACT IDLER

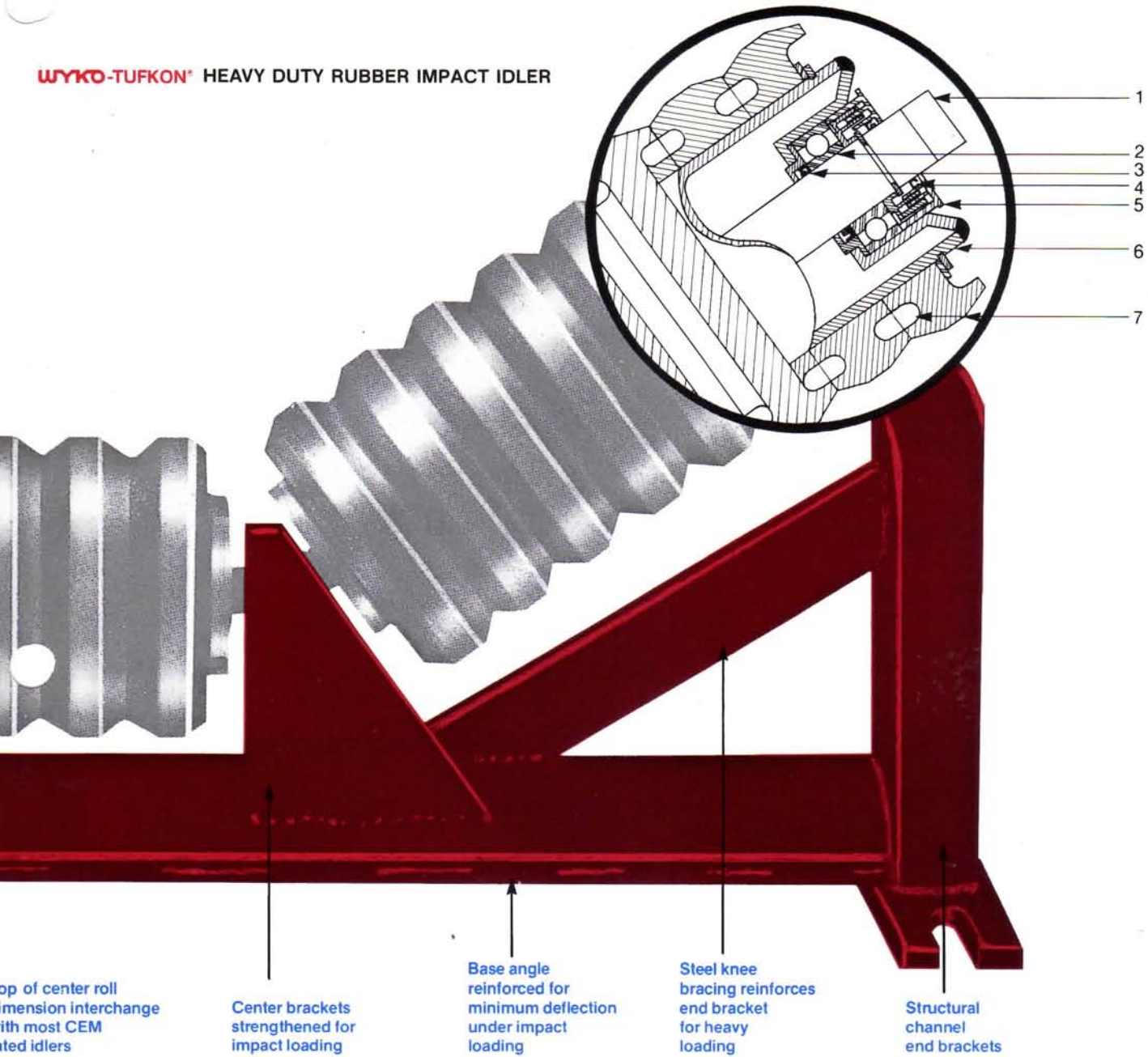

1. 1" diameter solid steel through shaft.
2. 1" diameter bearing.
3. Spring loaded rubber contact inner seal.
4. Spring loaded rubber contact seal.
5. Turbine type face labyrinth seal.

6. Heavy duty welded steel inner tube.
7. Patented semi-pneumatic, groove designed disc maximizes belt protection under impact loads.

WYKO-TUFKON® PATENTED DESIGN IS TESTED AND PROVEN IN A VARIETY OF APPLICATIONS INCLUDING:-

- Rock Products
- Sand and Gravel
- Cement
- Gypsum
- Grain and Food Products
- Fertilizers and AG Lime
- Coal
- Wood Chips

WYKO-TUFKON® PART NUMBER KEY

SAMPLE: 5" roll diameter, 35°Steel roll troughing idler, 36" B.W.
HT 5 3 36 S

SERIES	ROLL DIA.	DEGREE	BELT WIDTH	ROLL-TYPE
HT	4", 5" 6"	2 = 20° 3 = 35° 4 = 45° 0 = Flatbelt or Return	18-48	S = Steel Roll RI = Impact Roll R = Rubber Disc T = Trainer

WYKO-TUFKON® STEEL ROLL TROUGHING IDLERS

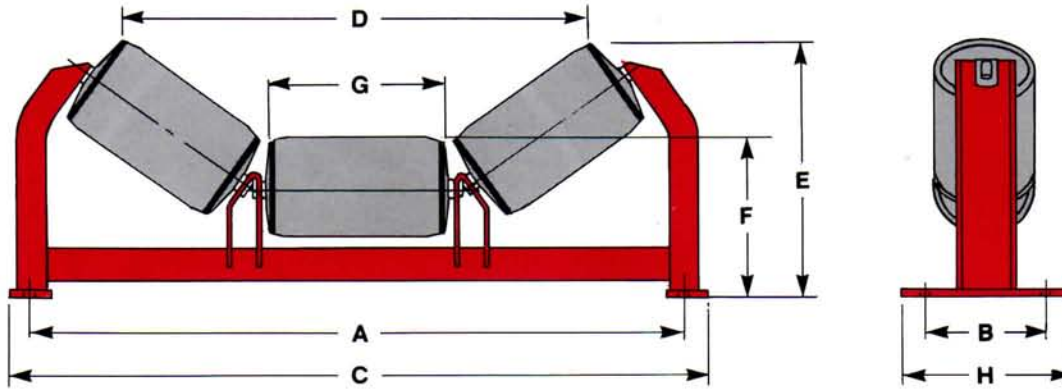

Slots for 5/8" bolts

20° EQUAL LENGTH

IDLER NUMBER			BW	A	B	C	D			E			F			G		H		WEIGHT		
4"	5"	6"					4"	5"	6"	4"	5"	6"	4"	5"	6"	4"	5"	6"	4,5"	6"	4"	5"
HT42-18S	HT52-18S	HT62-18S	18	27	6	29	21 1/4	21	22 1/8	10 3/8	11	11 1/4	8 1/2	8 1/2	9	6 1/8	7 1/4	8 1/2	10	32	38	51
HT42-24S	HT52-24S	HT62-24S	24	33	6	35	27 1/4	27	27 1/2	11 1/4	11 1/4	12 1/4	8 1/2	8 1/2	9	8 1/4	9 1/4	8 1/2	10	35	43	60
HT42-30S	HT52-30S	HT62-30S	30	39	6	41	33 3/4	33	33 1/2	12	12 1/2	13 1/8	9	9	9 1/2	10 3/8	11 1/4	8 1/2	10	43	54	69
HT42-36S	HT52-36S	HT62-36S	36	45	6	47	39 3/4	39	39 1/4	12 1/4	13 1/4	13 3/8	9	9	9 1/2	12 1/8	13 1/4	8 1/2	10	57	68	78
HT42-42S	HT52-42S	HT62-42S	42	51	7 1/2	53	45 1/4	45	45	13 3/8	13 3/8	14 1/8	9 1/2	9 1/2	9 1/2	14 1/8	15 1/4	10	10	63	75	87
HT42-48S	HT52-48S	HT62-48S	48	57	7 1/2	59	51 1/4	51	50 3/4	14 1/4	14 1/4	15 1/4	9 1/2	9 1/2	9 1/2	17	17 1/4	10	10	79	92	96
HT42-54S	HT52-54S	HT62-54S	54	63	9	65	57 1/4	57	56 3/4	15	15 1/2	16 1/8	9 1/2	9 1/2	10	19 1/8	19 1/4	11 1/2	11 1/2	95	102	108
HT42-60S	HT52-60S	HT62-60S	60	69	9	71	63 3/4	63	62 3/4	15 1/4	16 1/4	16 3/8	9 1/2	9 1/2	10	21 1/8	21 1/4	11 1/2	11 1/2	105	109	117

35° EQUAL LENGTH

IDLER NUMBER			BW	A	B	C	D			E			F			G		H		WEIGHT		
4"	5"	6"					4"	5"	6"	4"	5"	6"	4"	5"	6"	4"	5"	6"	4,5"	6"	4"	5"
HT43-18S	HT53-18S	HT63-18S	18	27	6	29	19	18 1/2	22 1/4	12 1/4	12 1/4	14 1/4	8 1/2	8 1/2	9	6 1/8	7 1/4	8 1/2	10	33	39	52
HT43-24S	HT53-24S	HT63-24S	24	33	6	35	24 1/2	24	24	13 1/2	13 3/8	14 1/2	8 1/2	8 1/2	9	8 1/4	9 1/4	8 1/2	10	37	45	64
HT43-30S	HT53-30S	HT63-30S	30	39	6	41	30	29 1/2	29 1/2	14 1/4	15	15 3/8	9	9	9 1/2	10 3/8	11 1/4	8 1/2	10	46	56	73
HT43-36S	HT53-36S	HT63-36S	36	45	6	47	35 1/2	35	34 1/4	15 1/4	16 1/4	16 1/8	9	9	9 1/2	12 1/8	13 1/4	8 1/2	10	49	60	83
HT43-42S	HT53-42S	HT63-42S	42	51	7 1/2	53	41	40 1/2	40	17	17 1/8	18	9 1/2	9 1/2	9 1/2	14 1/8	15 1/4	10	10	64	77	92
HT43-48S	HT53-48S	HT63-48S	48	57	7 1/2	59	46 1/2	46	45 1/2	18 1/4	18 1/2	19	9 1/2	9 1/2	9 1/2	17	17 1/4	10	10	81	84	99
HT43-54S	HT53-54S	HT63-54S	54	63	9	65	52	51 1/2	50 3/4	19	19 1/4	20 1/2	9 1/2	9 1/2	10	19 1/8	19 1/4	11 1/2	11 1/2	97	104	116
HT43-60S	HT53-60S	HT63-60S	60	69	9	71	57 1/4	57	56	19 1/4	20 1/4	21 1/4	9 1/2	9 1/2	10	21 1/8	21 1/4	11 1/2	11 1/2	105	111	126

45° EQUAL LENGTH

IDLER NUMBER			BW	A	B	C	D			E			F			G		H		WEIGHT		
4"	5"	6"					4"	5"	6"	4"	5"	6"	4"	5"	6"	4"	5"	6"	4,5"	6"	4"	5"
HT44-18S	HT54-18S	HT64-18S	18	27	6	29	17 1/4	16 1/4	17 1/4	13 1/4	13 1/4	13 1/8	8 1/2	8 1/2	9	6 1/8	7 1/4	8 1/2	10	36	43	50
HT44-24S	HT54-24S	HT64-24S	24	33	6	35	22 1/4	21 1/4	22 1/2	14 1/4	15 1/4	15 1/4	8 1/2	8 1/2	9	8 1/4	9 1/4	8 1/2	10	37	45	64
HT44-30S	HT54-30S	HT64-30S	30	39	6	41	27 1/2	26 1/2	27 1/4	16 1/4	16 1/4	17 1/8	9	9	9 1/2	10 3/8	11 1/4	8 1/2	10	51	60	71
HT44-36S	HT54-36S	HT64-36S	36	45	6	47	32 1/4	31 1/4	32	17 1/4	18	18 1/2	9	9	9 1/2	12 1/8	13 1/4	8 1/2	10	62	75	85
HT44-42S	HT54-42S	HT64-42S	42	51	7 1/2	53	38	37	38	19	19 1/2	19 3/4	9 1/2	9 1/2	9 1/2	14 1/8	15 1/4	10	10	68	84	95
HT44-48S	HT54-48S	HT64-48S	48	57	7 1/2	59	43	42	41 1/4	20 1/2	21	21 1/4	9 1/2	9 1/2	9 1/2	17	17 1/4	10	10	82	98	106
HT44-54S	HT54-54S	HT64-54S	54	63	9	65	48 1/2	47 1/2	47 1/4	22 1/4	22 1/4	23	9 1/2	9 1/2	10	19 1/8	19 1/4	11 1/2	11 1/2	96	112	120
HT44-60S	HT54-60S	HT64-60S	60	69	9	71	53 1/4	52 1/4	51 1/2	23 1/4	23	24 1/4	9 1/2	9 1/2	10	21 1/8	21 1/4	11 1/2	11 1/2	110	124	131

Have Dimensions Certified for Construction

WYKO-TUFKON® SELF-ALIGNING TROUGHING IDLERS

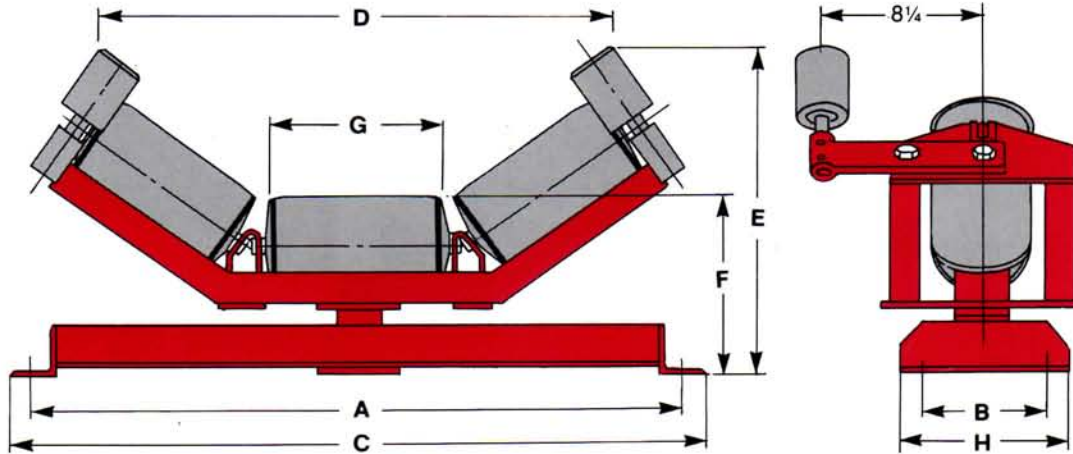

Slots for 5/8" bolts

20° EQUAL LENGTH SELF-ALIGNING IDLER

IDLER NUMBER			BW	A	B	C	D			E			F			G		H		WEIGHT		
4"	5"	6"					4"	5"	6"	4"	5"	6"	4"	5"	6"	4"	5"	6"	4,5"	6"	4,5"	6"
HT42-18ST	HT52-18ST	HT62-18ST	18	27	6	29	23 1/2	23 3/8	25 3/16	13 1/4	13 1/16	14	8 1/4	8 3/4	9 1/4	6 11/16	7 1/8	8 1/2	10	77	83	89
HT42-24ST	HT52-24ST	HT62-24ST	24	33	6	35	29 1/4	29	31 1/16	13 3/8	14 3/8	14 3/4	8 3/4	8 3/4	9 1/4	8 3/4	9 1/8	8 1/2	10	85	91	97
HT42-30ST	HT52-30ST	HT62-30ST	30	39	6	41	35 1/8	34 5/8	36 9/16	14 1/16	15 1/8	15 9/16	8 3/4	8 3/4	9 1/4	10 13/16	11 1/8	8 1/2	10	93	102	111
HT42-36ST	HT52-36ST	HT62-36ST	36	45	6	47	41 1/8	40 7/8	42 15/16	15 3/8	15 13/16	16 1/8	8 3/4	8 3/4	9 1/4	12 7/8	13 3/8	8 1/2	10	102	111	120
HT42-42ST	HT52-42ST	HT62-42ST	42	51	7 1/2	53	48	47 3/4	49 13/16	16 1/16	16 1/2	16 15/16	8 3/4	8 3/4	9 1/4	14 15/16	15 1/8	10	10	114	123	132
HT42-48ST	HT52-48ST	HT62-48ST	48	57	7 1/2	59	53 1/8	52 3/4	54 13/16	16 3/4	17 1/4	17 3/4	8 3/4	8 3/4	9 1/4	17	17 1/8	10	10	123	135	144
HT42-54ST	HT52-54ST	HT62-54ST	54	63	9	65	58 1/4	59 5/8	61	17 1/16	18 1/2	18 7/16	8 3/4	8 3/4	9 1/4	19 1/16	19 1/8	11 1/2	11 1/2	136	143	158
HT42-60ST	HT52-60ST	HT62-60ST	60	69	9	71	63 3/4	64 3/4	66	18 1/8	19 1/4	19 3/16	8 3/4	8 3/4	9 1/4	21 1/8	21 1/2	11 1/2	11 1/2	144	156	164

35° EQUAL LENGTH SELF-ALIGNING IDLER

IDLER NUMBER			BW	A	B	C	D			E			F			G		H		WEIGHT		
4"	5"	6"					4"	5"	6"	4"	5"	6"	4"	5"	6"	4"	5"	6"	4,5"	6"	4,5"	6"
HT43-18ST	HT53-18ST	HT63-18ST	18	27	6	29	19 1/2	18 3/4	19 15/16	14 9/16	15 1/16	16	8 1/4	8 3/4	9 1/4	6 11/16	7 1/8	8 1/2	10	78	84	90
HT43-24ST	HT53-24ST	HT63-24ST	24	33	6	35	24 5/8	24 3/8	25 1/2	16 3/8	16 5/8	17 5/16	8 3/4	8 3/4	9 1/4	8 3/4	9 3/16	8 1/2	10	86	92	98
HT43-30ST	HT53-30ST	HT63-30ST	30	39	6	41	28 1/2	29 7/8	30 15/16	17 1/8	17 13/16	18 9/16	8 3/4	8 3/4	9 1/4	10 13/16	11 1/4	8 1/2	10	94	103	112
HT43-36ST	HT53-36ST	HT63-36ST	36	45	6	47	35 3/4	31	36 9/16	18 1/2	19	19 13/16	8 3/4	8 3/4	9 1/4	12 7/8	13 3/16	8 1/2	10	103	112	121
HT43-42ST	HT53-42ST	HT63-42ST	42	51	7 1/2	53	41 1/4	40 5/8	42	19 11/16	20 3/16	21 1/4	8 3/4	8 3/4	9 1/4	14 15/16	15 9/16	10	10	115	124	133
HT43-48ST	HT53-48ST	HT63-48ST	48	57	7 1/2	59	46 3/4	46 1/8	47 9/16	20 7/8	21 3/8	22 5/8	8 3/4	8 3/4	9 1/4	17	17 1/2	10	10	124	136	145
HT43-54ST	HT53-54ST	HT63-54ST	54	63	9	65	52 1/4	47 5/8	52 7/8	23 11/16	23 3/4	23 13/16	8 3/4	8 3/4	9 1/4	19 1/16	19 5/16	11 1/2	11 1/2	137	144	159
HT43-60ST	HT53-60ST	HT63-60ST	60	69	9	71	57 3/4	53 3/8	58 1/2	24 13/16	24 7/8	25	8 3/4	8 3/4	9 1/4	21 1/8	21 11/16	11 1/2	11 1/2	145	157	165

45° EQUAL LENGTH SELF-ALIGNING IDLER

IDLER NUMBER			BW	A	B	C	D			E			F			G		H		WEIGHT		
4"	5"	6"					4"	5"	6"	4"	5"	6"	4"	5"	6"	4"	5"	6"	4,5"	6"	4,5"	6"
HT44-18ST	HT54-18ST	HT64-18ST	18	27	6	29	17 1/8	16 7/16	17 1/4	16	16 3/8	16 15/16	8 3/4	8 3/4	9 1/4	6 11/16	7 1/8	8 1/2	8 1/2	79	85	91
HT44-24ST	HT54-24ST	HT64-24ST	24	33	6	35	22 1/8	21 7/16	22 1/2	17 1/2	17 13/16	18 7/16	8 3/4	8 3/4	9 1/4	8 3/4	8 15/16	8 1/2	8 1/2	87	93	99
HT44-30ST	HT54-30ST	HT64-30ST	30	39	6	41	27 1/8	26 3/8	27 1/4	18 15/16	19 1/4	20 1/16	8 3/4	8 3/4	9 1/4	10 13/16	10 13/16	8 1/2	8 1/2	95	104	113
HT44-36ST	HT54-36ST	HT64-36ST	36	45	6	47	32 1/16	31 3/8	32 9/16	20 3/8	20 3/4	21 1/2	8 3/4	8 3/4	9 1/4	12 7/8	12 15/16	8 1/2	8 1/2	104	113	122
HT44-42ST	HT54-42ST	HT64-42ST	42	51	7 1/2	53	37 1/8	36 3/8	37 1/2	21 1/8	22 9/16	23 3/16	8 3/4	8 3/4	9 1/4	14 15/16	14 15/16	10	10	116	124	133
HT44-48ST	HT54-48ST	HT64-48ST	48	57	7 1/2	59	42 1/16	41 3/8	42 1/2	23 5/16	23 11/16	24 7/8	8 3/4	8 3/4	9 1/4	17	16 15/16	10	10	125	137	146
HT44-54ST	HT54-54ST	HT64-54ST	54	63	9	65	47 1/8	46 3/8	47 1/16	25 1/8	26 3/8	26 7/16	8 3/4	8 3/4	9 1/4	19 1/16	18 15/16	11 1/2	11 1/2	136	145	160
HT44-60ST	HT54-60ST	HT64-60ST	60	69	9	71	52 1/8	51 3/8	52 1/16	27 1/16	27 15/16	27 13/16	8 3/4	8 3/4	9 1/4	21 1/8	20 15/16	11 1/2	11 1/2	146	158	166

WYKO-TUFKON® RUBBER DISC IMPACT IDLER

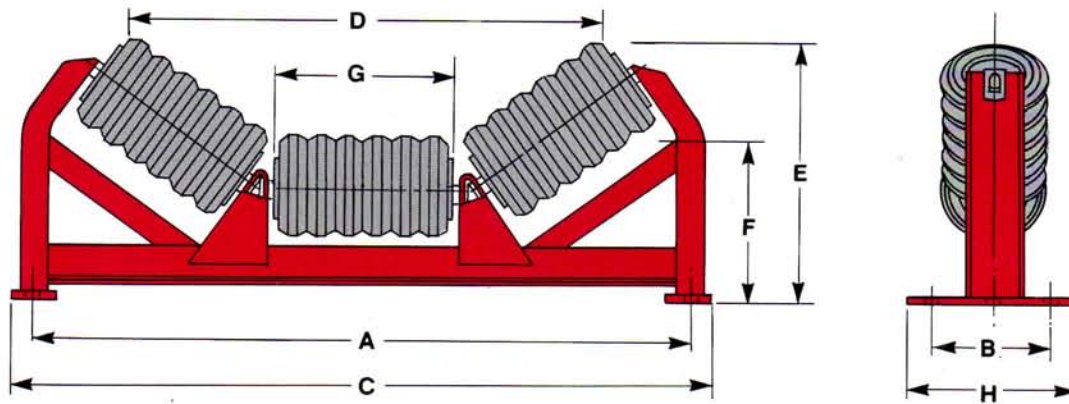

Slots for 5/8" bolts

20° EQUAL LENGTH IMPACT

IDLER NUMBER	BW	A	B	C	D	E	F	G	H	WEIGHT
5"										
HT52-18R	18	27	6	29	22 ¹ / ₈	10 ⁵ / ₈	8 ¹ / ₄	6 ¹ / ₁₆	8 ¹ / ₂	61
HT52-24R	24	33	6	35	26 ¹ / ₄	11 ³ / ₈	8 ¹ / ₄	8 ¹ / ₄	8 ¹ / ₂	74
HT52-30R	30	39	6	41	31 ⁵ / ₈	11 ¹¹ / ₁₆	8 ¹ / ₄	10 ¹³ / ₁₆	8 ¹ / ₄	92
HT52-36R	36	45	6	47	38 ¹ / ₈	12 ⁹ / ₁₆	8 ¹ / ₄	12 ⁷ / ₈	8 ¹ / ₂	107
HT52-42R	42	51	7 ¹ / ₂	53	43 ¹ / ₂	13 ¹ / ₈	8 ¹ / ₄	14 ¹³ / ₁₆	10	122
HT52-48R	48	57	7 ¹ / ₂	59	50 ¹ / ₈	13 ¹⁵ / ₁₆	8 ¹ / ₄	17	10	148

35° EQUAL LENGTH IMPACT

IDLER NUMBER	BW	A	B	C	D	E	F	G	H	WEIGHT
5"										
HT53-18R	18	27	6	29	18 ³ / ₄	11 ¹⁵ / ₁₆	8 ¹ / ₄	6 ¹ / ₁₆	8 ¹ / ₂	61
HT53-24R	24	33	6	35	23 ¹ / ₈	13	8 ¹ / ₄	8 ³ / ₄	8 ¹ / ₂	76
HT53-30R	30	39	6	41	28	14	8 ¹ / ₄	10 ¹³ / ₁₆	8 ¹ / ₂	94
HT53-36R	36	45	6	47	34	15 ⁵ / ₁₆	8 ¹ / ₄	12 ⁷ / ₈	8 ¹ / ₂	110
HT53-42R	42	51	7 ¹ / ₂	53	38 ⁷ / ₈	16 ³ / ₈	8 ¹ / ₄	14 ¹⁵ / ₁₆	10	125
HT53-48R	48	57	7 ¹ / ₂	59	44 ⁷ / ₈	17 ³ / ₄	8 ¹ / ₄	17	10	152

45° EQUAL LENGTH IMPACT

IDLER NUMBER	BW	A	B	C	D	E	F	G	H	WEIGHT
5"										
HT54-18R	18	27	6	29	18	13 ¹ / ₄	8 ¹ / ₄	6 ¹ / ₁₆	8 ¹ / ₂	63
HT54-24R	24	33	6	35	21 ¹ / ₂	14 ¹ / ₈	8 ¹ / ₄	8 ³ / ₄	8 ¹ / ₂	80
HT54-30R	30	39	8	41	26	15 ³ / ₈	8 ¹ / ₄	10 ¹³ / ₁₆	8 ¹ / ₂	99
HT54-36R	36	45	6	47	31 ³ / ₈	17 ¹ / ₁₆	8 ¹ / ₄	12 ⁷ / ₈	8 ¹ / ₂	115
HT54-42R	42	51	7 ¹ / ₂	53	36	18 ⁵ / ₁₆	8 ¹ / ₄	14 ¹⁵ / ₁₆	10	131
HT54-48R	48	57	7 ¹ / ₂	59	41 ³ / ₈	20	8 ¹ / ₄	17	10	151

Have Dimensions Certified for Construction

WYKO-TUFKON® RETURN AND FLATBELT IDLERS

SPACED RUBBER DISC RETURN IDLERS

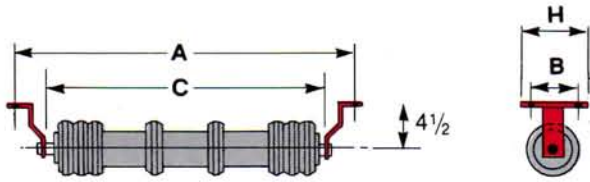

IDLER NUMBER	BW	No. DISC	A	B	C	H	WEIGHT
6"							
HT60-18R	18	7	27	4	20 ³ / ₄	6 ¹ / ₂	32
HT60-24R	24	8	33	4	26 ³ / ₄	6 ¹ / ₂	37
HT60-30R	30	9	39	4	32 ³ / ₄	6 ¹ / ₂	44
HT60-36R	36	10	45	4	38 ³ / ₄	6 ¹ / ₂	50
HT60-42R	42	11	51	4	44 ³ / ₄	6 ¹ / ₂	56
HT60-48R	48	12	57	4	50 ³ / ₄	6 ¹ / ₂	62

Note: Drop Brackets can be made to any dimension as required.

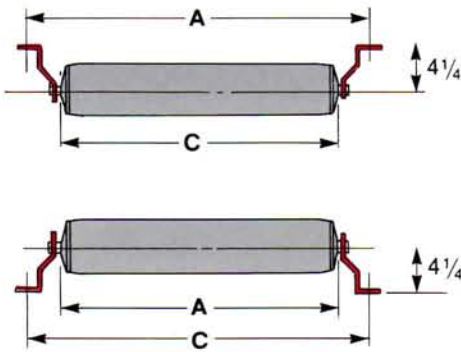

RETURN AND FLATBELT IDLERS

IDLER NUMBER			BW	A	C	WEIGHT		
4"	5"	6"				4"	5"	6"
HT40-18S	HT50-18S	HT60-18S	18	27	20 ¹³ / ₁₆	20	23	26
HT40-24S	HT50-24S	HT60-24S	24	33	26 ¹³ / ₁₆	24	28	32
HT40-30S	HT50-30S	HT60-30S	30	39	32 ¹³ / ₁₆	28	33	38
HT40-36S	HT50-36S	HT60-36S	36	45	38 ¹³ / ₁₆	32	37	42
HT40-42S	HT50-42S	HT60-42S	42	51	44 ¹³ / ₁₆	36	42	48
HT40-48S	HT50-48S	HT60-48S	48	57	50 ¹³ / ₁₆	40	46	52
HT40-54S	HT50-54S	HT60-54S	54	63	56 ¹³ / ₁₆	44	50	56
HT40-60S	HT50-60S	HT60-60S	60	69	62 ¹³ / ₁₆	48	54	62

Note: Drop brackets and rise brackets can be made to any dimension as required.

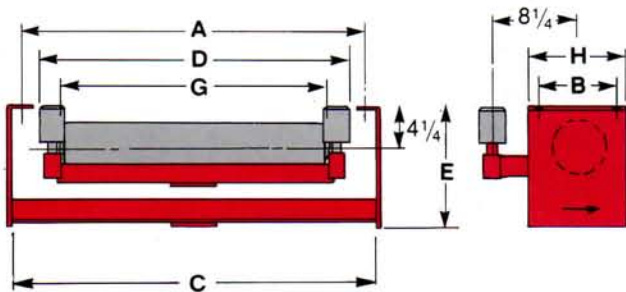

SELF-ALIGNING RETURN IDLERS

IDLER NUMBER											WEIGHT		
4"	5"	6"	BW	A	B	C	D	E	G	H	4"	5"	6"
HT40-18ST	HT50-18ST	HT60-18ST	18	27	6	25	24 ³ / ₈	9 ³ / ₄	20 ³ / ₈	8 ¹ / ₂	78	82	86
HT40-24ST	HT50-24ST	HT60-24ST	24	33	6	31	30 ³ / ₈	9 ³ / ₄	26 ³ / ₈	8 ¹ / ₂	86	92	96
HT40-30ST	HT50-30ST	HT60-30ST	30	39	6	37	36 ³ / ₈	9 ³ / ₄	32 ³ / ₈	8 ¹ / ₂	102	110	118
HT40-36ST	HT50-36ST	HT60-36ST	36	45	6	43	42 ³ / ₈	9 ³ / ₄	38 ³ / ₈	8 ¹ / ₂	112	121	130
HT40-42ST	HT50-42ST	HT60-42ST	42	51	7 ¹ / ₂	49	48 ³ / ₈	9 ³ / ₄	44 ³ / ₈	10	122	133	144
HT40-48ST	HT50-48ST	HT60-48ST	48	57	7 ¹ / ₂	55	54 ³ / ₈	9 ³ / ₄	50 ³ / ₈	10	132	145	158
HT40-54ST	HT50-54ST	HT60-54ST	54	63	9	61	60 ³ / ₈	9 ³ / ₄	56 ³ / ₈	11 ¹ / ₂	142	157	172
HT40-60ST	HT50-60ST	HT60-60ST	60	69	9	67	66 ³ / ₈	9 ³ / ₄	62 ³ / ₈	11 ¹ / ₂	152	169	186

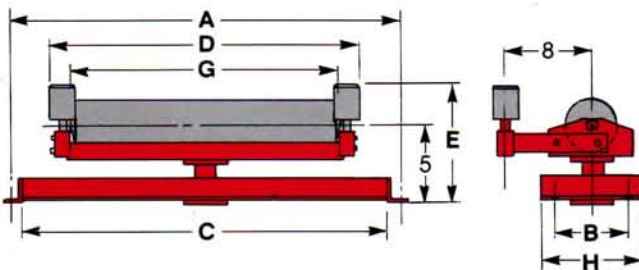

SELF-ALIGNING FLATBELT IDLERS

IDLER NUMBER											WEIGHT		
4"	5"	6"	BW	A	B	C	D	E	G	H	4"	5"	6"
HT40-18RT	HT50-18RT	HT60-18RT	18	27	6	25	24 ³ / ₈	9 ³ / ₄	20 ³ / ₈	9 ¹ / ₂	78	82	86
HT40-24RT	HT50-24RT	HT60-24RT	24	33	6	31	30 ³ / ₈	9 ³ / ₄	26 ³ / ₈	9 ¹ / ₂	86	92	96
HT40-30RT	HT50-30RT	HT60-30RT	30	39	6	37	36 ³ / ₈	9 ³ / ₄	32 ³ / ₈	9 ¹ / ₂	102	110	118
HT40-36RT	HT50-36RT	HT60-36RT	36	45	6	43	42 ³ / ₈	9 ³ / ₄	38 ³ / ₈	9 ¹ / ₂	112	121	130
HT40-42RT	HT50-42RT	HT60-42RT	42	51	7 ¹ / ₂	49	48 ³ / ₈	9 ³ / ₄	44 ³ / ₈	9 ¹ / ₂	122	133	144
HT40-48RT	HT50-48RT	HT60-48RT	48	57	7 ¹ / ₂	55	54 ³ / ₈	9 ³ / ₄	50 ³ / ₈	9 ¹ / ₂	132	145	158
HT40-54RT	HT50-54RT	HT60-54RT	54	63	9	61	60 ³ / ₈	9 ³ / ₄	56 ³ / ₈	9 ¹ / ₂	142	157	172
HT40-60RT	HT50-60RT	HT60-60RT	60	69	9	67	66 ³ / ₈	9 ³ / ₄	62 ³ / ₈	9 ¹ / ₂	152	169	186

Note: Also available with spaced rubber disc rolls.

WYKO-TUFKON®

PROVIDING THE FULL COMPONENT PACKAGE



SERVING ALL YOUR CONVEYOR REQUIREMENTS

- IDLERS
- PULLEYS
- SHAFT ASSEMBLIES
- ROLLER CHAIN AND SPROCKETS
- HOLDBACKS
- POWER TRANSMISSION EQUIPMENT

PLUS....Full Machine Shop Capabilities

WYKO-TUFKON® CONVEYOR COMPONENTS

MANUFACTURING AND SALES OFFICES:

P.O. BOX 130, GREENBACK, TENNESSEE 37742

PHONE (615) 856-2317 TELEX 6827104 FAX 615-856-2092

A Wyko Group PLC Company

AUTHORIZED DISTRIBUTOR:-



Box 130, Hwy. 411 South
Greenback, Tennessee 37742
Telephone: 615-856-2317
FAX: 615-856-2092

October 14, 1988

Mr. David K. Swindell, V.P.
Manufacturing
John B. Long Co.
P.O. Box 50608
Knoxville, TN 37950

Dear Mr. Swindell:

Per our telephone conversation, I have enclosed our brochure to introduce you to the WYKO-TUFKON patented line of conveyor components. We feel that our products are equal to any idlers on the market today and superior to most. All of our components are built to meet or exceed CEMA dimensions and are maintenance free. Our prices are competitive with the better components on the market and we are looking for distributors/end users in most market areas.

As a smaller, relatively new manufacturer of conveyor components, we have the flexibility to respond to our customers' needs in a timely and effective manner. We also are prepared to supply rolls only, since there's nothing more we enjoy than a head-to-head with our competitors' equipment.

I hope you will take time to study our literature. For more information and prices call us at (615)856-2317.

Sincerely,

A handwritten signature in black ink, appearing to read "Ian Smith", written over a horizontal line.

Mr. Ian Smith
President

IS/mf

Enclosure

cc: Mr. Delmar Dillan, Mgr. Engineering