

# Screw Conveyor Catalog & Engineering Manual

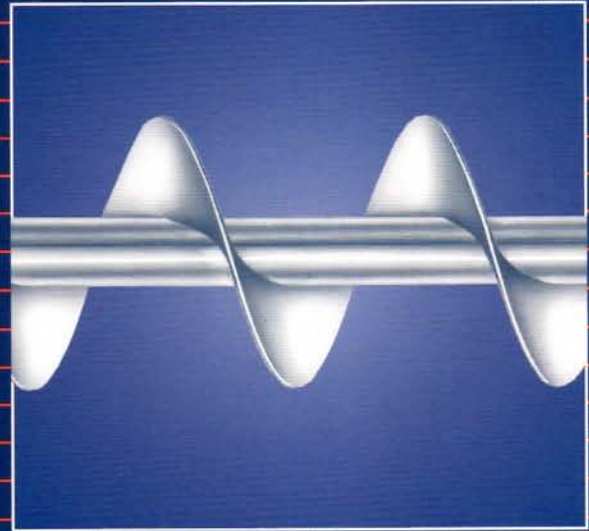

THE EXPERIENCE  
TO HANDLE IT RIGHT!

## Screw Conveyor Corporation

**SPECIAL NOTE:** For illustrative purposes many photographs, diagrams or sketches contained in this catalog show the conveyor top open, without a cover. This is for the sake of clarity only. Conveyors should never be installed, placed ready for operation, or operated without all covers, spouts and drive guards properly installed and secured.

# Manufacturing, Sales and Service Facilities Throughout The Country

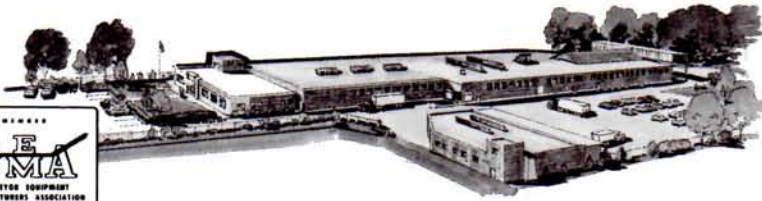

**Screw Conveyor Corporation**  
700 Hoffman Street  
Hammond, Indiana 46327-1894  
Phone: (219) 931-1450  
Fax: (800) 805-6527  
Web Site: [www.screwconveyor.com](http://www.screwconveyor.com)  
E-Mail: [sales@screwconveyor.com](mailto:sales@screwconveyor.com)



**Screw Conveyor Corporation**  
781 Church Street  
Winona, Mississippi 38967-2813  
Phone: (662) 283-3142  
Fax: (800) 213-3084  
E-Mail: [Winonasales@screwconveyor.com](mailto:Winonasales@screwconveyor.com)



**Screw Conveyor Corporation**  
915 West Ash Street  
Chanute, Kansas 66720-1501  
Phone: (620) 431-0440  
Fax: (800) 213-3086  
E-Mail: [Chanutesales@screwconveyor.com](mailto:Chanutesales@screwconveyor.com)

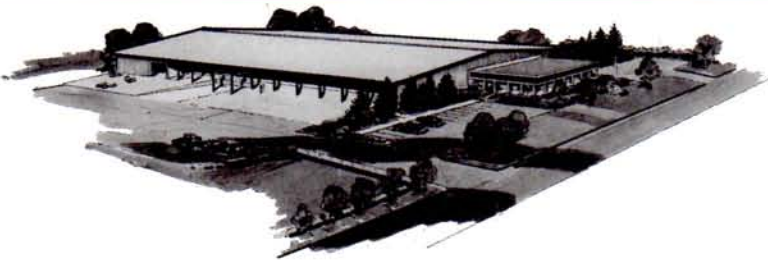

**Screw Conveyor Corporation**  
7807 Doe Avenue  
Visalia, California 93291-9220  
Phone: (559) 651-2131  
Fax: (800) 651-2135  
E-Mail: [Visaliasales@screwconveyor.com](mailto:Visaliasales@screwconveyor.com)



**Screw Conveyor De Mexico, S.A. De C.V.**  
Oscar Menendez #2522; Zona Industrial,  
Guadalajara, Jalisco, Mexico, C.P. 44940  
Phone: 011-52-333-645-7110  
Fax: 011-52-333-663-2369  
E-mail: [scm315@prodigy.net.mx](mailto:scm315@prodigy.net.mx)





# Screw Conveyor Catalog and Engineering Manual

This Screw Conveyor Catalog and Engineering Manual consolidates all pertinent engineering data with completely cataloged product descriptions of components making up the Screw Conveyor Corporation line of Horizontal Screw Conveyors, Inclined Screw Conveyors, Vertical Screw-Lift and Screw Conveyor Feeders.

These units are now used in virtually all industries as well as providing Original Equipment Manufacturers with specialized components to fit their design requirements.

It is sincerely hoped that you will find this manual complete in detail, easy to use and extremely helpful in fulfilling your conveying needs.

## Contents

General Information .....	Page 2-7
Engineering Information	
Horizontal Screw Conveyors .....	Page 8
Screw Feeders .....	Page 18
Inclined Screw Conveyors .....	Page 20
Drives .....	Page 21
Screw-Lifts .....	Page 22
Safety Precautions .....	Page 24
Screw Conveyor Components .....	Page 24-61
Supplementary Data .....	Page 62-63



## Screw Conveyors

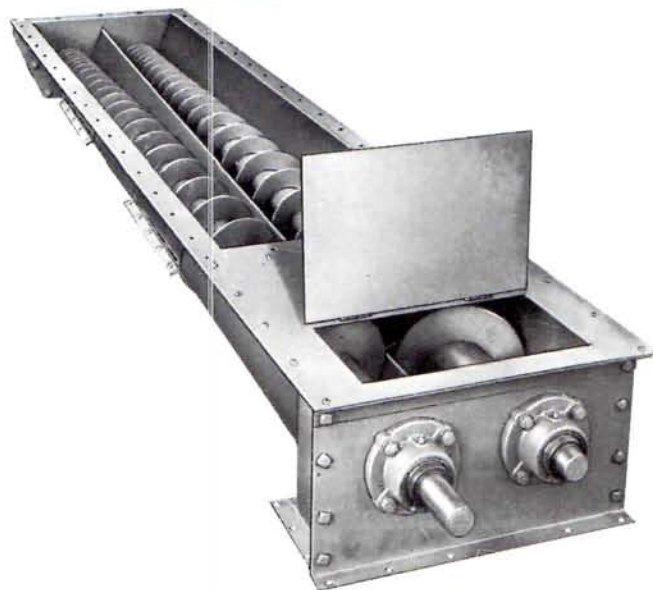

Screw conveyors move materials either horizontally, on an incline or vertically. They are used to feed, distribute, collect or mix and can be equipped to either heat or cool while performing this transfer. With the proper cover and gasketing, they are easily made dust or weather tight and rodent proof. Their clean compact design saves valuable space since no return run is required. Screw Conveyors fit in cramped quarters, are simple to support and easy to install . . . and they cost less than most other types of conveyors.

Screw Conveyor Corporation's performance-proved Screw Conveyors are ruggedly built and accurately manufactured to assure complete dependability as well as the versatility required to meet a wide range of job assignments.

Screw Conveyors are performing their assigned tasks in virtually all types of industries and, in addition, special designs are being developed for use as components in machinery and equipment.

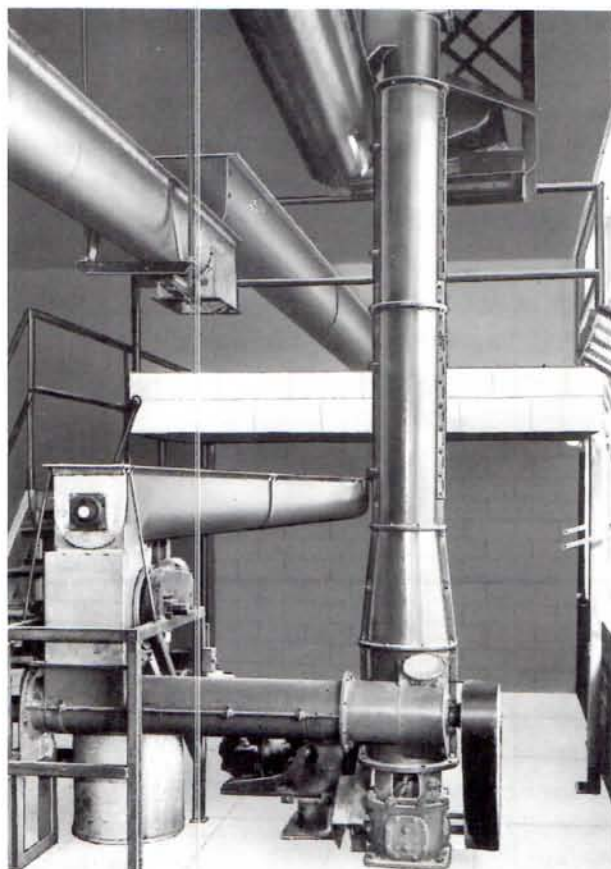

Screw Conveyors are performing their assigned tasks in virtually all types of industries and, in addition, special designs are being developed for use as components in machinery and equipment.

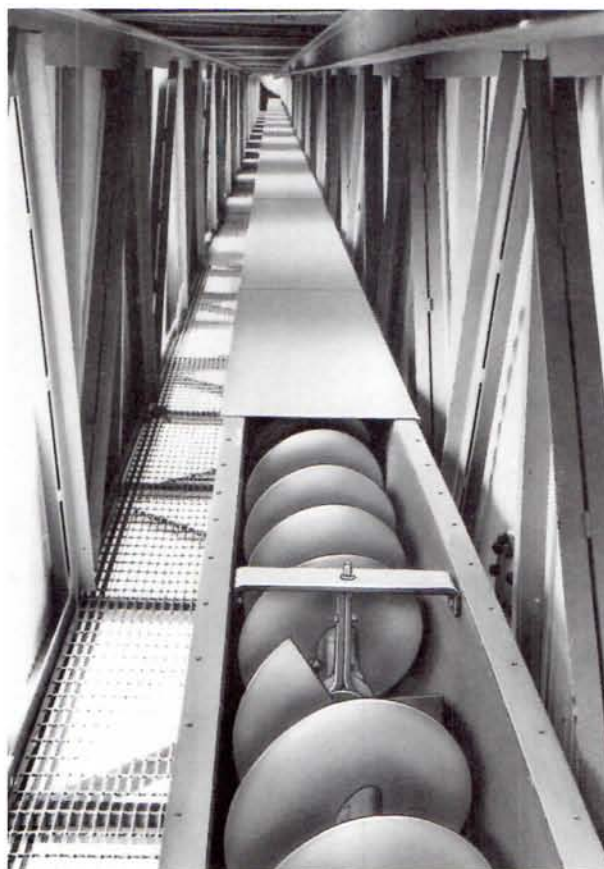

Screw Conveyor Corporation's performance-proved Screw Conveyor systems are ruggedly built and accurately manufactured to assure complete dependability as well as the versatility required to meet a wide range of job assignments.





## A Wide Choice of Standard Parts

You get the system you need to solve your problem — yet keep cost at a minimum. Select the type of component from our standard line that fits your needs. For special flighting designs to solve a particular problem, please consult with one of our four sales offices.

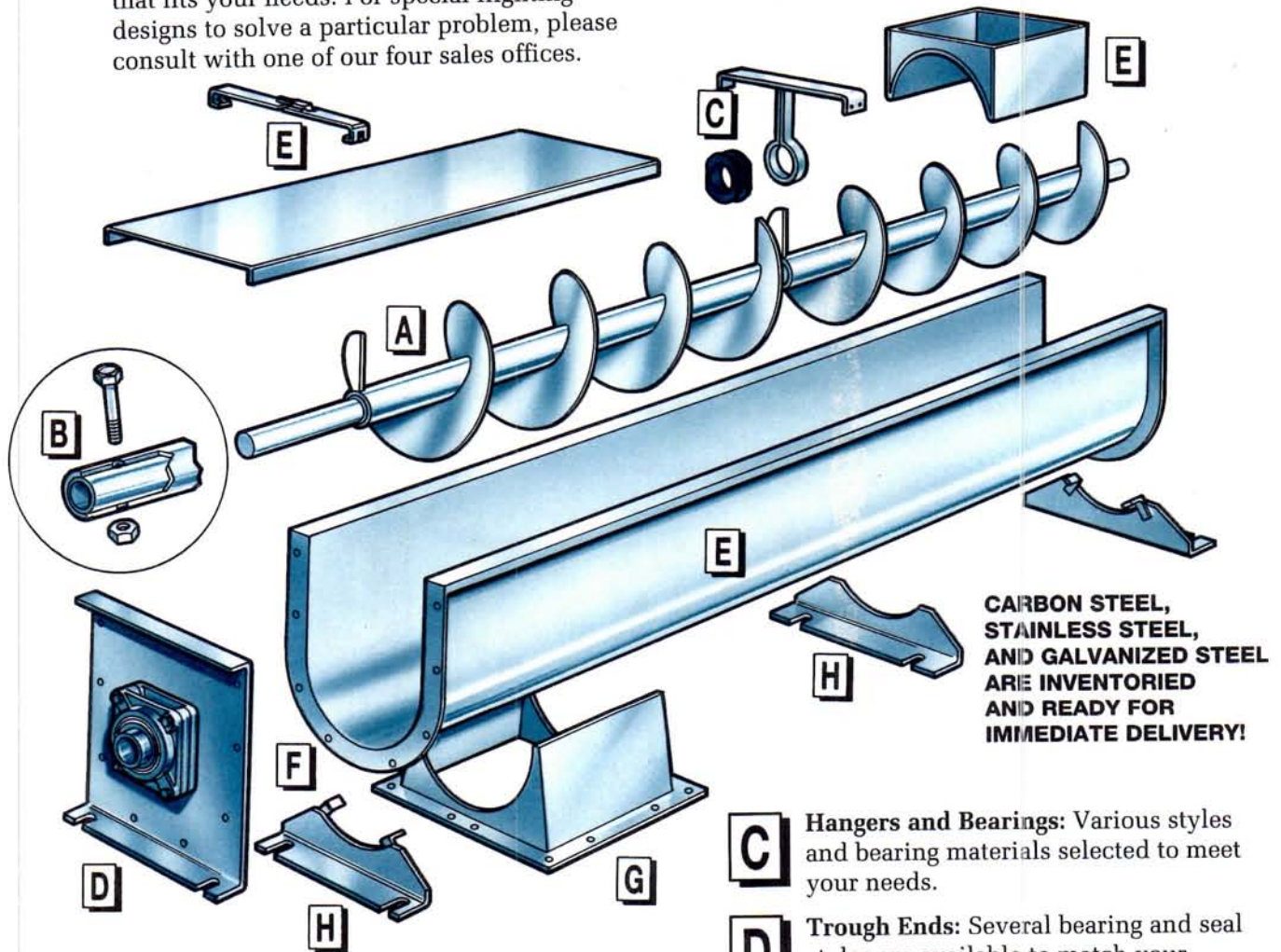

**CARBON STEEL,  
STAINLESS STEEL,  
AND GALVANIZED STEEL  
ARE INVENTORIED  
AND READY FOR  
IMMEDIATE DELIVERY!**

**A** **Conveyor Screw:** Compact, manufactured straight and accurate in helicoid, sectional, ribbon and special designs to meet your requirements.

**B** **Job-Rated Components:** Selected to meet the performance required. Precisely worked to insure a longer lasting, truer running unit.

**Jig-Drilled Couplings:** Assures easy shaft alignment and assembly. Available with "Redi-Change" clamping key for quick disassembly of conveyor screw.

**Tem-U-Lac Self-Locking Coupling Bolts:** Guards against system damage and costly down-time caused by coupling bolts or nuts working loose.

**C** **Hangers and Bearings:** Various styles and bearing materials selected to meet your needs.

**D** **Trough Ends:** Several bearing and seal styles are available to match your needs.

**E** **Troughs, Covers, Clamps and Shrouds:** Ruggedly constructed standard "U" and other styles of troughs including tubular. Covers, clamps and shrouds available for all applications.

**F** **Nu-Weld® Flange:** Continuously welded steel flange holds trough in alignment.

**G** **Discharge Spouts:** All types available... located where you need them...with hand, electric, hydraulic or pneumatic powered gates.

**H** **Supporting Feet and Saddles:** Align and fasten the trough to the floor or existing structure.





# Applications

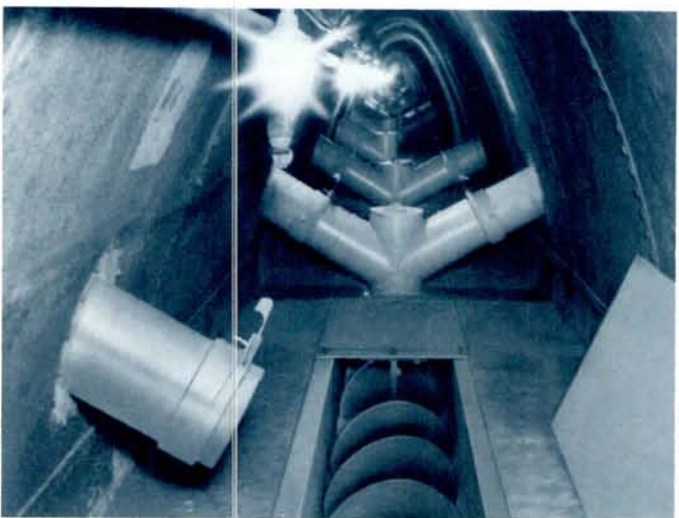

This Screw Conveyor in a tunnel installation illustrates the compact arrangement possible when space is at a premium.



This Matmaker asphalt finisher uses a Screw Conveyor at the back of the tractor unit to move material outward in both directions and spread it uniformly across the entire paving width.

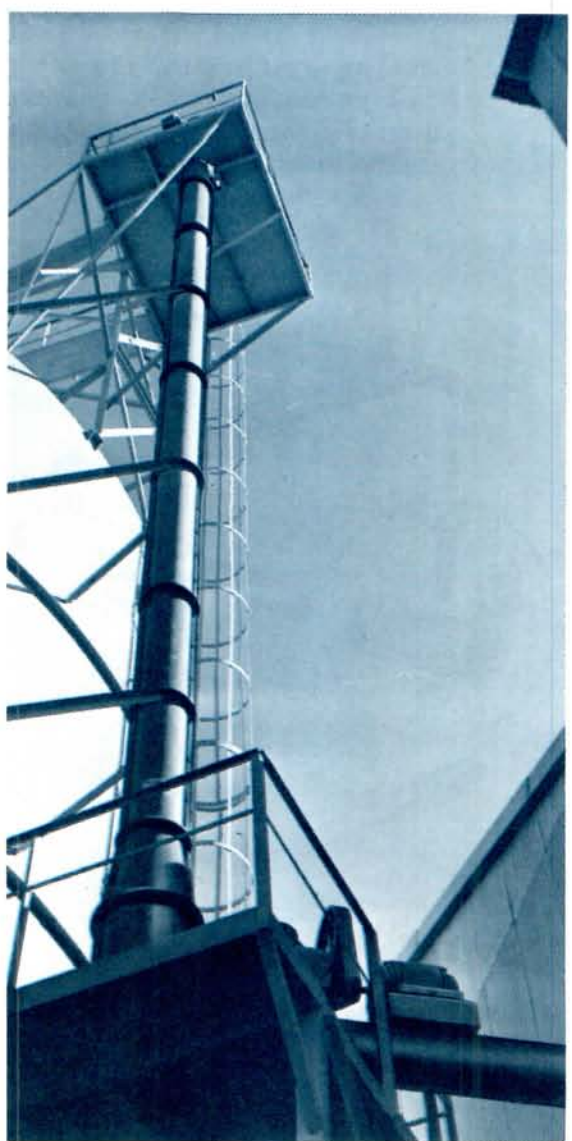

The Screw-Lift does an efficient elevating job as part of a complete Screw Conveyor system.



Screw Conveyor system and SCC Bucket Elevators speed grain handling for large facility. Two screw conveyors, running over two rows of tanks, are 494 feet long. Has double hanger in center so each half is powered independently. Between the two rows of tanks, a collecting screw conveyor, also with double hanger at center, is 528 feet long. System handles whole grains at approximately 100 tons per hour.



# Applications

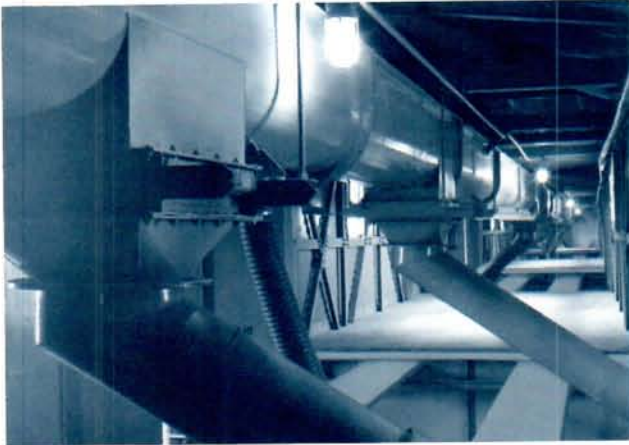

A Screw Conveyor installed in a large overhead operation. Space-saving features are apparent here. All parts of the system are enclosed yet readily accessible.



Special flighting provides fast, clean snow removal.



This asphalt fabric filter type dust collector uses Screw Conveyor flighting in the hoppers which return collected fines to the mix.



Partial view of a large outdoor installation employing Screw-Lifts to elevate material to fill storage silos.



Rubber reclaiming operation uses high capacity, compact Screw-Lift and screw conveyor system to transport rubber back and forth between mills and screener.



# Components of a Screw Conveyor System

**The Conveyor Screw** imparts a smooth positive motion to the material as it rotates within the trough.



**Couplings and Shafts** connect and transmit motion to subsequent screw conveyors. Held in place by self-locking Tem-U-Lac bolts.



**Redi-Change Sections** allow an individual conveyor section to be lifted out without dismantling adjacent parts or components. An optional feature available at extra cost.



**Hangers** provide support, maintain alignment and serve as bearing surfaces.







# Components of a Screw Conveyor System



**Trough Ends** support the conveyor drive and end shafts, maintain trough alignment. May be furnished with choice of bearings or thrust bearings.



**Troughs and Covers** completely enclose the material being conveyed and the rotating parts. Covers are available in various types and are secured to the trough by Spring, Screw, Tite-Seal or quick-acting Barron Clamps depending on the trough cover combination used.



**Inlet and Discharge Openings** may be located wherever needed, discharge spouts may be without slides or fitted with either flat or curved slides. These slides may be operated by hand, rack and pinion gears, or by power.

**The Complete Screw Conveyor Unit** is supported by the trough end and by either Feet or Saddles at intermediate locations.

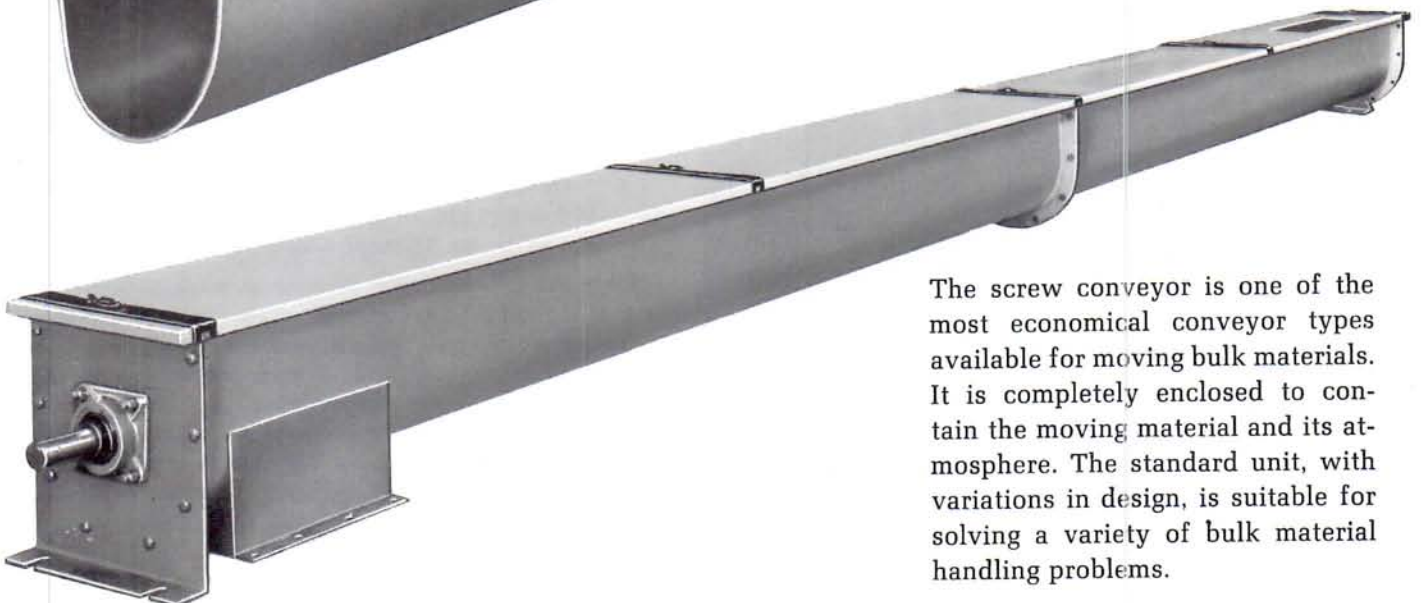

The screw conveyor is one of the most economical conveyor types available for moving bulk materials. It is completely enclosed to contain the moving material and its atmosphere. The standard unit, with variations in design, is suitable for solving a variety of bulk material handling problems.



# Design Data



## Engineering and Layout

This section contains all pertinent engineering data and procedures for prescribing and specifying the important features and details of most conveyor installations, however, Screw Conveyor Corporation staff engineers have considerable experience in the proper and successful application of Screw Conveyor design. Please feel free to contact our offices for case studies of your particular problem.

## Material Analysis

The initial step in engineering a Screw Conveyor is to analyze the physical characteristics of the material and the rate at which it is to be handled.

The capacity of a Screw Conveyor should be defined in terms of cubic feet per hour. It is also important to determine the maximum capacity the conveyor will be required to handle. This capacity is very often stated in terms of tons or pounds per hour. However, the material to be handled often varies in density. Therefore, the maximum volume or capacity in cubic feet per hour is the maximum pounds per hour of material divided by the minimum possible density of the material. It is volume to be conveyed which determines a conveyor's size and speed. Physical properties of the material to be thoroughly understood are the following:

1. Maximum lump size and the percentage of lumps to the total volume along with the minimum particle size and, if possible, a screen analysis.
2. Flowability characteristics. This is a term related to the angle of repose. See Material Classification, table No. 4, page 11.
3. The abrasive quality of a material can be defined by knowing its hardness on a Moh's scale. If this is not available, compare your material with another known abrasive material.
4. Additional factors which affect conveyor operation and design are further discussed on page 10 and are shown in the Material Classification table, page 11.

Please also note that moisture content, while not accounted for in the material tables, will affect the flow characteristics and density of a material. Some materials, when very dry or very wet will tend to have favorable flowability characteristics. Where the moisture content is between these extremes such a material may be quite sluggish and have a high angle of repose. Where this is a possibility, the material should be re-classified. Conveyor design and selection should proceed with the full knowledge of all conditions that can prevail.





# Design Data

No machinery design is complete without considering its usage. A conveyor that will be used intermittently for two hours a day does not have to be built as heavily as one that will operate twenty-four hours per day. Likewise, shock loads will effect the consideration given on gauge of steel used as well as drive equipment. Treatment of these factors and their affect on conveyor design are not discussed here in sufficient detail to prescribe. As mentioned previously, our engineers are available to assist you in every way possible to determine your best conveyor design.

Since the Screw Conveyor selected is based on a maximum volume control of material to be handled, surge loads, overloads and choke feeding must be accounted for in the conveyor design. Screw feeders are popularly used for this control and are discussed in other pages of this catalog.

## CLASSIFY YOUR MATERIAL

Materials are classified in table No. 6 on pages 12, 13 and 14. If your material is not listed, it can be classified by comparing it with similar materials that do appear in the table. If necessary, your material can be classified by referring to table No. 4 "Material Classifications", page 11.

## ESTABLISH REQUIRED DIAMETER AND SPEED

Knowing your material classification and required capacity, refer to the Capacity Chart, page 15. Your material classification indicates which trough loading applies. Select the size for your capacity using the smallest diameter conveyor that is below the maximum recommended speed. After size is determined then exact conveyor speed is determined by dividing the required capacity in cubic feet per hour by cubic feet per hour at 1 revolution per minute.

**Note:** If handling a material with hard lumps (lumps that will not break up in the Screw Conveyor) refer below to Table No. 1, "Size of Lumps to Diameter". If the required diameter (as found above) is smaller than the recommended size given in the Lump Chart, use the conveyor diameter from the chart Table #1 and then determine the RPM from Table #7.

Table No. 1 **MAXIMUM SIZE OF LUMPS, INCHES**

RATIO Lumps to Total Volume	Diameter of Conveyor, Inches									
	4	6	9	10	12	14	16	18	20	24
Lumps 10% or less.....	1	1½	2½	2½	3	3½	4	4½	5	6
Lumps 20% to 25%.....	½	¾	1½	1½	2	2½	3	3	3½	3¾
All Lumps.....	¼	½	¾	¾	1	1¼	1½	2	2	2½

## COMPONENT GROUP CLASSIFICATION

As shown in the Material table No. 6, pages 12, 13, and 14 each material is assigned to a Component Group. These groups take into account the material's physical characteristics and then match these with the proper conveyor components. A description of these components in each group can be found on page 11, table No. 5.

Please note that Babbitted bearings are considered standard where contamination from the required lubricants is not a factor. Oil impregnated wood or nylon bearings are often recommended where lubricant contamination is a factor. Ball bearings are not recommended for use in conveying gritty or very fine materials which might penetrate the oil seal. For abrasive or applications involving high temperatures, hard iron bearings are normally used. Other types of bearing materials furnished upon request.

## ESTABLISH THE "D" FACTOR

The "D" Factor is a constant applied to the particular Component Group of a given conveyor. To establish the "D" Factor, locate your conveyor diameter and bearing material in table No. 2. The figure appearing at this intersection is to be used as 'D' in the horsepower formula.

Table No. 2 **TABLE OF FACTORS "D"**

Size of Conveyor, Inches	TYPE OF HANGER BEARINGS			
	Ball or Roller	Wood, Babbitt, Nylon or Molded Fabric	Self- Lubricating Bronze	White Iron or Man- ganese Steel
3	10	15	24	35
4	12	21	33	50
6	18	33	54	80
9	32	54	96	130
10	38	66	114	160
12	55	96	171	250
14	78	135	255	350
16	106	186	336	480
18	140	240	414	600
20	165	285	510	700
24	230	390	690	950

## ESTABLISH THE REQUIRED HORSEPOWER

The formula stated below gives the horsepower (HP) required at the conveyor drive shaft for a standard conveyor.

Additional power will be required for starting under load, overcoming choke loads or other unusual conditions. There is also a loss of power through the drive machinery of from 10% to 15%. To compensate for these factors, the formula for the required motor horsepower is divided by .90.

Step No. 1

$$H = \frac{L (DS \text{ plus } QF)}{1,000,000}$$

where

L = Overall length in feet

D = Bearing Factor (see "D" Factor table) (Table No. 2)

S = Speed in RPM (see Capacity Chart)

Q = Quantity of material being conveyed in lbs./hr.

F = Horsepower factor "F" (see Material Tables)

Step No. 2

Motor Horsepower = H x P

P = 2 when H is less than 1

P = 1.5 when H is between 1 and 2

P = 1.25 when H is between 2 and 4

P = 1.1 when H is between 4 and 5

P = 1 when H is greater than 5

Step No. 3

$$\frac{HP}{.90} = \text{Minimum Recommended Horsepower}$$

## CONVEYOR HORSEPOWER RATINGS

One of the factors that must be considered now is to check the required horsepower from the above formula against the torque and horsepower capacity limitation for each conveyor pipe and shaft size.

Use table 3, page 10 which shows the maximum allowable horsepower at various conveyor speeds.

Example: a 9" conveyor mounted on 2" standard pipe, bushed for 1½" diameter couplings, is limited to a maximum of 5 HP at 100 RPM. If, in a given application, a larger motor is required, it is then necessary to use a 9" conveyor mounted on 2½" pipe, bushed for 2" diameter couplings. You will see that this arrangement is rated at 12 HP at 100 RPM or 6 HP at 50 RPM. These ratings are on the basis of two coupling bolts at each end of the conveyor pipe. In some sizes three bolts can be used to increase the drive limitation shown. Consult our Engineering Department for specific recommendations if in doubt.





**Table No. 3 HORSEPOWER RATINGS**

Size of Conveyor, Inches	Pipe Size Inches	Coupling Dia.	Max. HP @ 125 RPM	Max. HP @ 100 RPM	Max. HP @ 75 RPM	Max. HP @ 50 RPM
6, 9, and 10	2	1½	6.25	5	3.75	2.5
9, 10, and 12	2½	2	15.0	12	9.0	6.0
12 and 14	3	2⅞	18.75	15.0	11.25	7.5
12, 14, 16 18 and 20	3½	3	30.75	24.6	18.5	12.3
20 and 24	4	3⅞	43.75	35.0	26.25	17.5

### SAMPLE PROBLEM

Establish the conveyor size, speed, horsepower and other specifications necessary for conveying 1,800 bushels of dry, clean wheat per hour for a distance of 50 feet.

### SOLUTION

Refer to the Material table No. 6, pages 12, 13 and 14. Note:

Average weight/cu. ft. of wheat is 45-48 lbs.

The material classification is 47C<sub>v</sub>25N

The recommended types of conveyors are 1A, 1B, 1C

The "F" Factor is .4

The material classification, C<sub>v</sub>25N indicates the material is granular - ½ inch and under, very free flowing - angle of repose up to 30°, non-abrasive and contains explosive dust. The recommended types of conveyors, 1A, 1B, 1C indicate the group that is designed for normal service. (See table 5, page 11 and Capacity table 7, page 15.)

Convert the given capacity from bushels per hour to cubic feet per hour. Known: there are 1.25 cubic feet in a bushel of wheat. Therefore, 1,800 x 1.25 equals 2,250 cubic feet per hour. Now, 2,250 cu. ft. per hour x 48 lbs. equals 108,000 lbs./hr. This will be assumed to be the maximum desired capacity.

Turn to the Capacity Chart table No. 7, page 15 and establish the conveyor diameter and proper speed. As you will note C25 material class has a 45% recommended trough loading and 2,250 cu. ft./hr. requires a 12" diameter screw conveyor operating at 116 RPM (EXAMPLE: 2,250/19.4 = 115.9 or 116 RPM.) Remember, do not exceed the maximum recommended speed without first consulting with our staff engineers. If hard lumps had been present, we would now consult table No. 1, page 9.

We now know that:

L = 50 feet

D = 96 (see "D" Factor table, (table No. 2) 12" conveyor with wood bearings)

S = 116 RPM (see Capacity Chart)

Q = 108,000 lbs./hr.

F = .4 (see Material Tables)

Now, inserting these figures in the formula:

$$H = \frac{50(96 \times 116 + 108,000 \times .4)}{1,000,000}$$

Therefore: H = 2.8

Motor Horsepower equals H x P (see value of P under formula)

Therefore: 2.8 x 1.25 = 3.5

To be assured of having sufficient power, divide the HP by .90. This gives you a minimum recommended horsepower of 3.9. Your minimum choice of motor size would, therefore, be 5 HP.

Now, refer to the Torque Capacity table No. 3 and note the minimum pipe size for a 12" conveyor is 2½". Maximum allowable horsepower for this conveyor's specifications is 15 HP. Since this figure is in excess of our requirements, we can use the computed 5 HP motor.

Additional Screw Conveyor specifications for indoor operation will be:

Group Classification: 1A

Conveyor Size and Speed: 12" at 120 RPM

Conveyor Screw: 12" Standard Helicoid

Conveyor Trough: 12" No. 12 gauge steel, Double Flange Construction, Flanged Cover and Barron Clamps

Type of hanger bearings: 12" x 2" bore, intermediate hanger with babbit bearings

Refer to page 17 for additional Layout Data and Details.

### SPECIAL APPLICATIONS AND SPECIFICATIONS

The selection procedure, outlined above, takes into account the material's physical characteristics, provides for the proper cross-section loading of a conveyor and specifies, through the component tables, the type of conveyor components to be used. Some material's physical characteristics will require additional special features.

### ABRASIVE MATERIALS

Abrasive materials tend to cause excessive wear on Screw Conveyor components and should be carried at low cross-sectional loads and at relatively slow conveyor speeds. For conveyors which will handle extremely abrasive materials or will be subjected to heavy or continuous service, heavy-duty components should be specified. Heavier than standard, surface-hardened or abrasive resistant steels are available for this application.

There are also some materials that are normally considered abrasive which may easily become aerated, thus reflecting a minimum density and greater flowability. Here it is possible to use higher speeds and in some cases, higher cross-sectional loads. Judgment and experience, however, will dictate the conditions when this can occur.

### CONTAMINABLE MATERIALS

When handling easily contaminable materials, such as food products or some chemicals, it is possible to specify components and other features of construction which were not necessarily included and made a part of the conveyor selection process. These features would include non-lubricating type intermediate hanger bearings, seals under the end bearings, easily removable trough covers and, possibly, drop bottom conveyor trough construction. Accessibility to the internal parts of the conveyor through the use of some of these features means the conveyor can be easily inspected and cleaned out.

Conveyor Flighting may be continuously welded to the conveyor pipe on either/or both sides of the flight. Grinding and cleaning of the welds can remove scale and/or roughness that could contribute to contamination.

### CORROSIVE MATERIALS

When handling bulk materials which are corrosive, conveyor components manufactured from stainless steel, aluminum or other special alloys are available, also hot dipped galvanized carbon steel components may be used in non-abrasive applications.

### DEGRADABLE MATERIALS

Materials which tend to break or separate easily, affecting quality, may be handled in larger diameter, slower turning Screw Conveyors to reduce agitation.

### EXTREME TEMPERATURES

Materials may be heated or cooled while being conveyed in a jacketed conveyor. When handling materials in extreme temperatures, specify Screw Conveyor components of metal alloys designed to meet these conditions.

### FLUIDIZING MATERIALS

When agitated, some materials tend to "aerate" and react similar to a liquid. When handling these materials, it is





# Design Data

Table No. 5 **COMPONENT GROUP SPECIFICATIONS**

important to know the aerated density so that conveyor size and speed will be based on the larger aerated volume. When a volumetric type feeder is used, the horsepower should be based on the design volume and maximum material density.

### MIXING MATERIALS

If the materials are to be mixed or agitated while being conveyed, ribbon flights, cut flights, cut and folded flight or one of the above in combination with paddles, may be used.

### MATERIALS WHICH PACK AND RESIST DIGGING

Some materials have very strong resistance to digging which means that it is difficult, and in some cases, impossible to shear a pile of the material or to penetrate it with a sharp edge such as in a conveyor flight. Offsetting the conveyor screw and placement of an angle inside the trough on the carrying side will enable some of these materials to be handled.

Occasionally, materials tend to pack under pressure and become hard in the clearance between the conveyor screw and trough. Some of these materials can then be conveyed satisfactory if the Screw Conveyor is operated at low speeds and the edge of the flight is used as a cutting edge.

### HYGROSCOPIC MATERIALS

Materials which readily absorb moisture and hygroscopic. Such materials become less free flowing as they absorb moisture. This factor must be taken into account when determining conveyor size, HP and speed. Some hygroscopic materials can, as they absorb moisture, change in density and angle of repose and thus, effect the material classification number.

### TOXIC MATERIALS

If harmful vapors or dust are released by agitation and conveying, the system should be of sealed construction.

### VISCOUS OR STICKY MATERIALS

Viscous materials can best be handled by Ribbon Conveyors because they usually have a tendency to stick and adhere to the joint of the conveyor pipe and flight on a standard conveyor.

Table No. 4 **MATERIAL CLASSIFICATION**

	Material Characteristics	Class Designation
Size	No. 200 Sieve (.0029") And Under	A <sub>200</sub>
	No. 100 Sieve (.0059") And Under	A <sub>100</sub>
	No. 40 Sieve (.016") And Under	A <sub>40</sub>
	Fine No. 6 Sieve (.132") And Under	B <sub>6</sub>
	1/2" And Under	C <sub>1/2</sub>
	Granular 3" And Under	D <sub>3</sub>
Flowability	7" And Under	D <sub>7</sub>
	16" And Under	D <sub>16</sub>
	*Lumpy Over 16" To Be Specified X = Actual Maximum Size	D <sub>x</sub>
	Irregular Stringy, Fibrous, Cylindrical, Slabs, Etc.	E
Flowability	Very Free Flowing - Flow Function 10	1
	Free Flowing - Flow Function 4 But 10	2
	Average Flowability - Flow Function 2 But 4	3
	Sluggish - Flow Function 2	4
Abrasiveness	Mildly Abrasive - Index 1-17	5
	Moderately Abrasive - Index 18-67	6
	Extremely Abrasive - Index 68-416	7
Miscellaneous Properties Or Hazards	Builds Up and Hardens	F
	Generates Static Electricity	G
	Decomposes - Deteriorates in Storage	H
	Flammability	J
	Becomes Plastic or Tends to Soften	K
	Very Dusty	L
	Aerates and Becomes Fluid	M
	Explosiveness	N
	Stickiness-Adhesion	O
	Contaminable, Affecting Use	P
	Degradable, Affecting Use	Q
	Gives Off Harmful or Toxic Gas or Fumes	R
	Highly Corrosive	S
Mildly Corrosive	T	
Hygroscopic	U	
Interlocks, Mats or Agglomerates	V	
Oils Present	W	
Packs Under Pressure	X	
Very Light and Fluffy - May Be Windswept	Y	
Elevated Temperature	Z	

Screw Size Inches	Coupling Diameter Inches	Screw Number	Trough Thickness	Cover Thickness
<b>Normal Service</b> Component group 1A • babbitted bearing hangers Component group 1B • wood bearing hangers Component group 1C • ball bearing hangers regular trough regular flights cold rolled steel couplings				
6	1½	6H304	16 ga.	16 ga.
9	1½	9H306	14 ga.	14 ga.
		9H406	14 ga.	14 ga.
12	2	12H408	12 ga.	14 ga.
		12H508	12 ga.	14 ga.
14	2½	14H508	12 ga.	14 ga.
16	3	16H610	12 ga.	14 ga.
18	3	18H610	10 ga.	12 ga.
20	3	20H610	10 ga.	12 ga.
24	3¾	24S712	10 ga.	14 ga.
<b>Heavy service</b> Component group 2A □ • babbitted bearing hangers cold rolled steel couplings Component group 2B □ • wood bearing hangers cold rolled steel couplings Component group 2C □ • ball bearing hangers cold rolled steel couplings Component group 2D △ • hard iron bearing hangers hardened steel couplings heavy trough heavy flights				
6	1½	6H308	14 ga.	16 ga.
9	1½	9H312	10 ga.	14 ga.
		9H412	10 ga.	14 ga.
12	2	12H412	¾	14 ga.
		12H512	¾	14 ga.
		12H614	¾	14 ga.
14	2½	14S512	¾	14 ga.
		14H614	¾	14 ga.
16	3	16H614	¾	14 ga.
18	3	18S616	¾	12 ga.
20	3	20S616	¾	12 ga.
24	3¾	24S716	¾	12 ga.
<b>Extra heavy service</b> Component group 3A □ • babbitted bearing hangers cold rolled steel couplings Component group 3D △ • hard iron bearing hangers hardened steel couplings extra-heavy trough extra-heavy flights				
6	1½	6H312	10 ga.	16 ga.
9	1½	9H312	¾	14 ga.
		9H414	¾	14 ga.
12	2	12H412	¾	14 ga.
		12H512	¾	14 ga.
		12H614	¾	14 ga.
14	3	14H614	¾	14 ga.
16	3	16H614	¾	14 ga.
18	3	18S624	¾	12 ga.
20	3	20S624	¾	12 ga.
24	3¾	24S724	¾	12 ga.

- For use with nonabrasive materials.
- For use with nonabrasive irregular material or lumpy material containing lumps over ½".
- △ For use with mildly abrasive material.
- ▽ For use with mildly corrosive materials.
- For use with very abrasive materials.





# Material Table

Table No. 6

MATERIAL	WEIGHT LBS. PER CU. FT.	MATERIAL CLASS	COMPONENT GROUP	H.P. MATERIAL FACTOR F	MATERIAL	WEIGHT LBS. PER CU. FT.	MATERIAL CLASS	COMPONENT GROUP	H.P. MATERIAL FACTOR F
Adipic Acid	45	45A10035	2B	.5	Bronze Chips	30-50	40B645	2D	2.0
Alfalfa Meal	14-22	18B645WY	2D	.6	Buckwheat	37-42	40B625N	1A-1B-1C	.4
Alfalfa Pellets	41-43	42C $\frac{1}{2}$ 25	2D	.5	Calcine, Flour	75-85	80A10035	1A-1B-1C	.7
Alfalfa Seed	10-15	13B615N	1A-1B-1C	.4	Calcium Carbide	70-90	80D325N	2D	2.0
Almonds, Broken	27-30	29C $\frac{1}{2}$ 35Q	2D	.9	Calcium Carbonate (See Limestone)	--	--	--	--
Almonds, Whole Shelled	28-30	29C $\frac{1}{2}$ 35Q	2D	.9	Calcium Fluoride (See Fluorspar)	--	--	--	--
Alum, Fine	45-50	48B635U	1A-1B-1C	.6	Calcium Hydrate (See Lime, Hydrated)	--	--	--	--
Alum, Lumpy	50-60	55B625	2A-2B	1.4	Calcium Hydroxide (See Lime, Hydrated)	--	--	--	--
Alumina	55-65	58B627MY	3D	1.8	Calcium Lactate	26-29	28D345QTR	2A-2B	.6
Alumina Fines	35	35A10027MY	3D	1.6	Calcium Oxide (See Lime, unslaked)	--	--	--	--
Alumina Sized or Briquette	65	65D337	3D	2.0	Calcium Phosphate	40-50	45A10045	1A-1B-1C	1.6
Aluminate Gel (Aluminate Hydroxide)	45	45B635	2D	1.7	Calcium Sulfate (See Gypsum)	--	--	--	--
Aluminum Chips, Dry	7-15	11E45V	2D	1.2	Carbon, Activated, Dry, Fine*	--	--	--	--
Aluminum Chips, Oily	7-15	11E45V	2D	.8	Carbon, Black, Pelleted*	--	--	--	--
Aluminum Hydrate	13-20	17C $\frac{1}{2}$ 35	1A-1B-1C	1.4	Carbon, Black, Powder*	--	--	--	--
Aluminum Ore (See Bauxite)	--	--	--	--	Carborundum	100	100D327	3D	3.0
Aluminum Oxide	60-120	90A10017M	3D	1.8	Casein	36	36B635	2D	1.6
Aluminum Silicate (Andalusite)	49	49C $\frac{1}{2}$ 35S	3A-3B	.8	Cashew Nuts	32-37	35C $\frac{1}{2}$ 45	2D	.7
Aluminum Sulfate	45-58	52C $\frac{1}{2}$ 25	1A-1B-1C	1.0	Cast Iron, Chips	130-200	165C $\frac{1}{2}$ 45	2D	4.0
Ammonium Chloride, Crystalline	45-52	49A10045FRS	3A-3B	.7	Caustic Soda	88	88B635RSU	3D	1.8
Ammonium Nitrate	45-62	54A4035NTU	3D	1.3	Caustic Soda, Flakes	47	47C $\frac{1}{2}$ 45RSUX	3A-3B	1.5
Ammonium Sulfate	45-58	52C $\frac{1}{2}$ 35FOTU	1A-1B-1C	1.0	Celite (See Diatomaceous Earth)	--	--	--	--
Antimony Powder	--	A10035	2D	1.6	Cement, Clinker	75-95	85D336	3D	1.8
Apple Pomace, Dry	15	15C $\frac{1}{2}$ 45Y	2D	1.0	Cement, Mortar	133	133B635Q	3D	3.0
Arsenate of Lead (See Lead Arsenate)	--	--	--	--	Cement, Portland	94	94A10026M	2D	1.4
Arsenic Oxide (Arsenolite)*	100-120	110A10035R	--	--	Cement, Aerated (Portland)	60-75	68A10016M	2D	1.4
Arsenic Pulverized	30	30A10025R	2D	.8	Cerrusite (See Lead Carbonate)	--	--	--	--
Asbestos-Rock (Ore)	81	81D337R	3D	1.2	Chalk, Crushed	75-95	85D325	2D	1.9
Asbestos-Shredded	20-40	30E46XY	2D	1.0	Chalk, Pulverized	67-75	71A10025MXY	2D	1.4
Ash, Black Ground	105	105B635	1A-1B-1C	2.0	Charcoal, Ground	18-28	23A10045	2D	1.2
Ashes, Coal, dry - 1/2"	35-45	40C $\frac{1}{2}$ 46TY	3D	3.0	Charcoal, Lumps	18-28	23D345Q	2D	1.4
Ashes, Coal, dry - 3"	35-40	38D346T	3D	2.5	Chocolate, Cake Pressed	40-45	43C325	2B	1.5
Ashes, Coal, Wet - 1/2"	45-50	48C $\frac{1}{2}$ 46T	3D	3.0	Chrome Ore	125-140	133D336	3D	2.5
Ashes, Coal, Wet - 3"	45-50	48D346T	3D	4.0	Cinders, Blast Furnace	57	57D336T	3D	1.9
Ashes, Fly (See Fly Ash)	--	--	--	--	Cinders, Coal	40	40C336T	3D	1.8
Asphalt, Crushed - 1/2"	45	45C $\frac{1}{2}$ 45	1A-1B-1C	2.0	Clay (See Bentonite, Diatomaceous Earth, Fuller's Earth, Kaolin & Marl)	--	--	--	--
Bagasse	7-10	9E45RVXY	2A-2B-2C	1.5	Clay, Ceramic, Dry, Fines	60-80	70A10035P	1A-1B-1C	1.5
Bakelite, Fine	30-45	38B625	1A-1B-1C	1.4	Clay, Calcined	80-100	90B636	3D	2.4
Baking Powder	40-55	48A10035	1B	.6	Clay, Brick, Dry, Fines	100-120	110C $\frac{1}{2}$ 36	3D	2.0
Baking Soda (Sodium Bicarbonate)	40-55	48A10025	1B	.6	Clay, Dry, Lumpy	60-75	68D335	2D	1.8
Barite (Barium Sulfate) + 1/2" - 3"	120-180	150D336	3D	2.6	Clinker, Cement (See Cement Clinker)	--	--	--	--
Barite, Powder	120-180	150A10035X	2D	2.0	Clover Seed	45-58	47B625N	1A-1B-1C	.4
Barium Carbonate	72	72A10045R	2D	1.6	Coal, Anthracite (River & Culm)	55-61	60B635TY	2A-2B	1.0
Bark, Wood, Refuse	10-20	15E45TVY	3D	2.0	Coal, Anthracite, Sized - 1/2"	49-61	55C $\frac{1}{2}$ 25	2A-2B	1.0
Barley, Fine, Ground	24-38	31B635	1A-1B-1C	.4	Coal, Bituminous, Mined	40-60	50D335LNXY	1A-1B	.9
Barley, Malted	31	31C $\frac{1}{2}$ 35	1A-1B-1C	.4	Coal, Bituminous, Mined, Sized	45-50	48D335QV	1A-1B	1.0
Barley, Meal	28	28C $\frac{1}{2}$ 35	1A-1B-1C	.4	Coal, Bituminous, Mined, Slack	43-50	47C $\frac{1}{2}$ 45T	2A-2B	.9
Barley, Whole	36-48	42B625N	1A-1B-1C	.5	Coal, Lignite	37-45	41D335T	2D	1.0
Basalt	80-105	93B627	3D	1.8	Cocoa Beans	30-45	38C $\frac{1}{2}$ 25Q	1A-1B	.5
Bauxite, Dry, Ground	68	68B625	2D	1.8	Cocoa, Nibs	35	35C $\frac{1}{2}$ 25	2D	.5
Bauxite, Crushed - 3"	75-85	80D336	3D	2.5	Cocoa, Powdered	30-35	33A10045XY	1B	.9
Beans, Castor, Meal	35-40	38B635W	1A-1B-1C	.8	Cocoonut, Shredded	20-22	21E45	2B	1.5
Beans, Castor, Whole Shelled	36	36C $\frac{1}{2}$ 15W	1A-1B-1C	.5	Coffee, Chaff	20	20B625MY	1A-1B	1.0
Beans, Navy, Dry	48	48C $\frac{1}{2}$ 15	1A-1B-1C	.5	Coffee, Green Bean	25-32	29C $\frac{1}{2}$ 25PQ	1A-1B	.5
Beans, Navy, Steeped	60	60C $\frac{1}{2}$ 25	1A-1B-1C	.8	Coffee, Ground, Dry	25	25A4035P	1A-1B	.6
Bentonite, Crude	34-40	37D345X	2D	1.2	Coffee, Ground, Wet	35-45	40A4045X	1A-1B	.6
Bentonite, - 100 Mesh	50-60	55A10025MXY	2D	.7	Coffee, Roasted Bean	20-30	25C $\frac{1}{2}$ 25PQ	1B	.4
Benzene Hexachloride	56	56A10045R	1A-1B-1C	.6	Coffee, Soluble	19	19A4035PUY	1B	.4
Bicarbonate of Soda (Baking Soda)	--	--	1B	.6	Coke, Breeze	25-35	30C $\frac{1}{2}$ 37	3D	1.2
Blood, Dried	35-45	40D345U	2D	2.0	Coke, Loose	23-35	30D337	3D	1.2
Blood, Ground, Dried	30	30A10035U	1A-1B	1.0	Coke, Petrol, Calcined	35-45	40D337	3D	1.3
Bone Ash (Tricalcium Phosphate)	40-50	45A10045	1A-1B	1.6	Compost	30-50	40D745TV	3A-3B	1.0
Boneblack	20-25	23A10025Y	1A-1B	1.5	Concrete, Pre-Mix Dry	85-120	103C $\frac{1}{2}$ 36U	3D	3.0
Bonechar	27-40	34B635	1A-1B	1.6	Copper Ore	120-150	135D336	3D	4.0
Bonemeal	50-60	55B635	2D	1.7	Copper Ore, Crushed	100-150	125D336	3D	4.0
Bones, Whole*	35-50	43E45V	2D	3.0	Copper Sulphate, (Bluestone)	75-95	85C $\frac{1}{2}$ 35S	2A-2B-2C	1.0
Bones, Crushed	35-50	45D345	2D	2.0	Copperas (See Ferrous Sulphate)	--	--	--	--
Bones, Ground	50	50B635	2D	1.8	Copra, Cake Ground	40-45	43B645HW	1A-1B-1C	.7
Borate of Lime	60	60A10035	1A-1B-1C	1.6	Copra, Cake, Lumpy	25-30	28D335HW	2A-2B-2C	.8
Borax, Fine	45-55	50B625T	3D	1.8	Copra, Lumpy	22	22E35HW	2A-2B-2C	1.0
Borax Screening - 1/2"	55-60	58C $\frac{1}{2}$ 35	2D	1.5	Copra, Meal	40-45	42B635HW	2D	.7
Borax, 1 1/2" - 2" Lump	55-60	58D335	2D	1.8	Cork, Fine Ground	5-15	10B635JNY	1A-1B-1C	.5
Borax, 2" - 3" Lump	60-70	65D335	2D	2.0	Cork, Granulated	12-15	14C $\frac{1}{2}$ 35JY	1A-1B-1C	.5
Boric Acid, Fine	55	55B625T	3D	.8	Corn, Cracked	40-50	45B625P	1A-1B-1C	.7
Boron	75	75A10037	2D	1.0	Corn Cobs, Ground	17	17C $\frac{1}{2}$ 25Y	1A-1B-1C	.6
Bran, Rice-Rye-Wheat	16-20	18B635NY	1A-1B-1C	.5	Corn Cobs, Whole*	12-15	14E35	2A-2B	--
Braunite (Manganese Oxide)	120	120A10036	2D	2.0	Corn Ear*	56	56E35	2A-2B	--
Bread Crumbs	20-25	23B635PQ	1A-1B-1C	.6	Corn Germ	21	21B635PY	1A-1B-1C	.4
Brewer's Grain, spent, dry	14-30	22C $\frac{1}{2}$ 45	1A-1B-1C	.5	Corn Grits	40-45	43B635P	1A-1B-1C	.5
Brewer's Grain, spent, wet	55-60	58C $\frac{1}{2}$ 45T	2A-2B	.8	Cornmeal	32-40	36B635P	1A-1B	.5
Brick, Ground - 1/8"	100-120	110B637	3D	2.2					





# Material Table

Table No. 6

MATERIAL	WEIGHT LBS. PER CU. FT.	MATERIAL CLASS	COMPONENT GROUP	H.P. MATERIAL FACTOR F	MATERIAL	WEIGHT LBS. PER CU. FT.	MATERIAL CLASS	COMPONENT GROUP	H.P. MATERIAL FACTOR F
Corn Oil, Cake	25	25D745HW	1A-1B	.6	Ice, Shell	33-35	34D3450	1B	.4
Corn Seed	45	46C725PO	1A-1B-1C	.4	Ilmenite Ore	140-160	15D337	3D	2.0
Corn Shelled	45	46C725	1A-1B-1C	.4	Iron Ore Concentrate	120-180	15A4037	3D	2.2
Corn Sugar	30-35	33B635PU	1B	1.0	Iron Oxide Pigment	25	25A10036LMP	1A-1B-1C	1.0
Cottonseed, Cake, Crushed	40-45	43C745HW	1A-1B	1.0	Iron Oxide, Millscale	75	75D736	2D	1.6
Cottonseed, Cake, Lumpy	40-45	43D745HW	2A-2B	1.0	Iron Pyrites (See Ferrous Sulfide)	--	--	--	--
Cottonseed, Dry, Delinted	22-40	31C725X	1A-1B	.6	Iron Sulphate (See Ferrous Sulfate)	--	--	--	--
Cottonseed, Dry, Not Delinted	18-25	22C745XY	1A-1B	.9	Iron Sulfide (See Ferrous Sulfide)	--	--	--	--
Cottonseed, Flakes	20-25	23C735HWY	1A-1B	.8	Iron Vitriol (See Ferrous Sulfate)	--	--	--	--
Cottonseed, Hulls	12	12B635Y	1A-1B	.9	Kafir (Corn)	40-45	43C725	3D	.5
Cottonseed, Meal, Expeller	25-30	28B645HW	3A-3B	.5	Kaolin Clay	63	63D325	2D	2.0
Cottonseed, Meal, Extracted	35-40	37B645HW	1A-1B	.5	Kaolin Clay-Tale	42-56	49A4035LMP	2D	2.0
Cottonseed, Meats, Dry	40	40B635HW	1A-1B	.6	Kryolith (See Cryolite)	--	--	--	--
Cottonseed, Meats, Rolled	35-40	38C745HW	1A-1B	.6	Lactose	32	32A4035PU	1B	.6
Cracklings, Crushed	40-50	45D345HW	2A-2B-2C	1.3	Lamp Black (See Carbon Black)	--	--	--	--
Cryolite, Dust	75-90	83A10036L	2D	2.0	Lead Arsenate	72	72A4035R	1A-1B-1C	1.4
Cryolite, Lumpy	90-110	100D1636	2D	2.1	Lead Arsenite	72	72A4035R	1A-1B-1C	1.4
Cullet, Fine	80-120	100C737	3D	2.0	Lead Carbonate	240-260	250A4035R	2D	1.0
Cullet, Lump	80-120	100D1637	3D	2.5	Lead Ore - 1/2"	200-270	235B635	3D	1.4
Culm, (See Coal, Anthracite)	--	--	--	--	Lead Ore - 1/4"	180-230	205C736	3D	1.4
Cupric Sulphate (Copper Sulfate)	--	--	--	--	Lead Ore - 1/8"	30-150	90A10035P	2D	1.2
Detergent (See Soap Detergent)	--	--	--	--	Lead Oxide (Red Lead) - 100 Mesh	30-180	105A20035LP	2D	1.2
Diatomaceous Earth	11-17	14A4036Y	3D	1.6	Lead Oxide (Red Lead) - 200 Mesh	30-180	105A20035LP	2D	1.2
Dicalcium Phosphate	40-50	45A4035	1A-1B-1C	1.6	Lead Sulphide - 100 Mesh	240-260	250A10035R	2D	--
Disodium Phosphate	25-31	28A4035	3D	.5	Lignite (See Coal Lignite)	--	--	--	--
Distiller's Grain-Spent Dry	30	30B635	2D	.5	Limante, Ore, Brown	120	120C747	3D	1.7
Distiller's Grain, Spent Wet	40-60	50C745V	3A-3B	.8	Lime, Ground, Unslaked	60-65	63B635U	1A-1B-1C	.6
Dolomite, Crushed	80-100	90C736	2D	2.0	Lime Hydrated	40	40B635LM	2D	.8
Dolomite, Lumpy	90-100	95D36	2D	2.0	Lime, Hydrated, Pulverized	32-40	36A4035LM	1A-1B	.6
Earth, Loam, Dry, Loose	76	76C736	2D	1.2	Lime, Pebble	53-56	55C725HU	2A-2B	2.0
Ebonite, Crushed	63-70	67C735	1A-1B-1C	1.8	Limestone, Agricultural	68	68B635	2D	2.0
Egg Powder	16	16A4035MPY	1B	1.0	Limestone, Crushed	85-90	85D36	2D	2.0
Epsom Salts (Magnesium Sulfate)	40-50	45A4035U	1A-1B-1C	.8	Limestone, Dust	55-95	75A4046MY	2D	1.6-2.0
Feldspar, Ground	65-80	73A10037	2D	2.0	Lindane (Benzene Hexachloride)	--	--	--	--
Feldspar, Lumps	90-100	95D37	2D	2.0	Linseed (See Flaxseed)	--	--	--	--
Feldspar, Powder	100	100A20036	2D	2.0	Litharge (Lead Oxide)	--	--	--	--
Feldspar, Screenings	75-80	78C737	2D	2.0	Lithopone	45-50	48A32535MR	1A-1B	1.0
Ferrous Sulfide - 1/2"	120-135	128C726	1A-1B-1C	2.0	Maize (See Milo)	--	--	--	--
Ferrous Sulfide - 100M	105-120	113A10036	1A-1B-1C	2.0	Malt, Dry, Ground	20-30	25B635NP	1A-1B-1C	.5
Ferrous Sulphate	50-75	63C735U	2D	1.0	Malt, Dry Whole	20-30	25C735N	1A-1B-1C	.5
Fish Meal	35-40	38C745HP	1A-1B-1C	1.0	Malt, Meal	36-40	38B625P	1A-1B-1C	.4
Fish Scrap	40-50	45D745H	2A-2B-2C	1.5	Malt, Sprouts	13-15	14C735P	1A-1B-1C	.4
Flaxseed	43-45	44B635X	1A-1B-1C	.4	Magnesium Chloride (Magnesite)	33	33C745	1A-1B	1.0
Flaxseed Cake (Linseed Cake)	48-50	49D745W	2A-2B	.7	Manganese Dioxide*	70-85	78A10035NRT	2A-2B	1.5
Flaxseed Meal (Linseed Meal)	25-45	35B645W	1A-1B	.4	Manganese Ore	125-140	133D37	3D	2.0
Flour Wheat	33-40	37A4045LP	1B	.6	Manganese Oxide	120	120A10036	2D	2.0
Flue Dust, Basic Oxygen Furnace	45-60	53A4036LM	3D	3.5	Manganese Sulfate	70	70C737	3D	2.4
Flue Dust, Blast Furnace	110-125	118A4036	3D	3.5	Marble, Crushed	80-95	83B637	3D	2.0
Flue Dust, Boiler H. Dry	30-45	38A4036LM	3D	2.0	Marl, (Clay)	80	80D36	2D	1.6
Fluorspar, Fine (Calcium Fluoride)	80-100	90B636	2D	2.0	Meat, Ground	50-55	53E45HOTX	2A-2B	1.5
Fluorspar, Lumps	90-110	100D736	2D	2.0	Meat, Scrap (W/bone)	40	40E46H	2A-2B	1.5
Flyash	30-45	38A4036M	3D	2.0	Mica, Flakes	17-22	20B616MY	2D	1.0
Foundry Sand, Dry (See Sand)	--	--	--	--	Mica, Ground	13-15	14B636	2D	.9
Fuller's Earth, Dry, Raw	30-40	35A4025	2D	2.0	Mica, Pulverized	13-15	14A10036M	2D	1.0
Fuller's Earth, Oily, Spent	60-65	63C745OW	3D	2.0	Milk, Dried, Flake	5-6	6B635PUY	1B	.4
Fuller's Earth, Calcined	40	40A10025	3D	2.0	Milk, Malted	27-30	29A4045PX	1B	.9
Galena (See Lead Sulfide)	--	--	--	--	Milk, Powdered	20-45	33B625PM	1B	.5
Gelatine, Granulated	32	32B635PU	1B	.8	Milk Sugar	32	32A10035PX	1B	.6
Gilsonite	37	37C735	3D	1.5	Milk, Whole, Powdered	20-36	28B635PUX	1B	.5
Glass, Batch	80-100	90C737	3D	2.5	Mill Scale (Steel)	120-125	123E46T	3D	3.0
Glue, Ground	40	40B645U	2D	1.7	Milo, Ground	32-36	34B625	1A-1B-1C	.5
Glue, Pearl	40	40C735U	1A-1B-1C	.5	Milo Maize (Kafir)	40-45	43B615N	1A-1B-1C	.4
Glue, Veg. Powdered	40	40A4045U	1A-1B-1C	.6	Molybdenite Powder	107	107B626	2D	1.5
Gluten, Meal	40	40B635P	1B	.6	Monosodium Phosphate	50	50B636	2D	.6
Granite, Fine	80-90	85C727	3D	2.5	Mortar, Wet*	150	150E46T	3D	3.0
Grape, Pomace	15-20	18D45U	2D	1.4	Mustard Seed	45	45B615N	1A-1B-1C	.4
Graphite Flake	40	40B625LP	1A-1B-1C	.5	Naphthalene Flakes	45	45B635	1A-1B-1C	.7
Graphite Flour	28	28A10035LMP	1A-1B-1C	.5	Niacin (Nicotinic Acid)	35	35A4035P	2D	.8
Graphite Ore	65-75	70D35L	2D	1.0	Oat Hulls	8-12	10B635NY	1A-1B-1C	.5
Guano Dry*	70	70C735	3A-3B	2.0	Oats	26	26C725MNM	1A-1B-1C	.4
Gypsum, Calcined	55-60	58B635U	2D	1.6	Oats, Crimped	19-26	23C735	1A-1B-1C	.5
Gypsum, Calcined, Powdered	60-80	70A10035U	2D	2.0	Oats, Crushed	22	22B645NY	1A-1B-1C	.6
Gypsum, Raw - 1"	70-80	75D325	2D	2.0	Oats, Flour	35	35A10035	1A-1B-1C	.5
Hay, Chopped*	8-12	10C735JY	2A-2B	1.6	Oats, Rolled	19-24	22C735NY	1A-1B-1C	.6
Hexanedioic Acid (See Adipic Acid)	--	--	--	--	Oleo Margarine (Margarine)	59	59E45HKPWX	2A-2B	.4
Hominy, Dry	35-50	43C725D	1A-1B-1C	.4	Orange Peel, Dry	15	15E45	2A-2B	1.5
Hops, Spent, Dry	35	35D335	2A-2B-2C	1.0	Oxalic Acid Crystals - Ethane Diacid Crystals	60	60B635OS	1A-1B	1.0
Hops, Spent, Wet	50-55	53D345V	2A-2B	1.5	Oyster Shells, Ground	50-60	55C736T	3D	1.6-2.0
Ice, Crushed	35-45	40D335D	2A-2B	.4	Oyster Shells, Whole	80	80D336TV	3D	2.1-2.5
Ice, Flaked*	40-45	43C735U	1B	.6	Paper Pulp (4% or less)	62	62E45	2A-2B	1.5
Ice, Cubes	33-35	34D335U	1B	.4	Paper Pulp (6% to 15%)	60-62	61E45	2A-2B	1.5





# Material Table

Table No. 6

MATERIAL	WEIGHT LBS. PER CU. FT.	MATERIAL CLASS	COMPONENT GROUP	H.P. MATERIAL FACTOR F	MATERIAL	WEIGHT LBS. PER CU. FT.	MATERIAL CLASS	COMPONENT GROUP	H.P. MATERIAL FACTOR F
Paraffin Cake - 1/2"	45	45C <sub>1/2</sub> 45K	1A-1B	6	Slate, Ground, - 1/4"	82-85	84B <sub>6</sub> 36	2D	1.6
Peanuts, Clean, in shell	15-20	18D <sub>3</sub> 35Q	2A-2B	6	Sludge, Sewage, Dried	40-50	45E477W	3D	.8
Peanut Meal	30	30B <sub>6</sub> 35P	1B	6	Sludge, Sewage, Dry Ground	45-55	50B46S	2D	.8
Peanuts, Raw, Uncleaned (unshelled)	15-20	18D <sub>3</sub> 36Q	3D	7	Soap, Beads or Granules	15-35	25B <sub>6</sub> 35Q	1A-1B-1C	.6
Peanuts, Shelled	35-45	40C <sub>1/2</sub> 35Q	1B	4	Soap, Chips	15-25	20C <sub>1/2</sub> 35Q	1A-1B-1C	.6
Peas, Dried	45-50	48C <sub>1/2</sub> 15NQ	1A-1B-1C	5	Soap Detergent	15-50	33B <sub>6</sub> 35FQ	1A-1B-1C	.8
Perlite-Expanded	8-12	10C <sub>1/2</sub> 36	2D	6	Soap, Flakes	5-15	10B <sub>6</sub> 35QXY	1A-1B-1C	.6
Phosphate Acid Fertilizer	60	60B <sub>6</sub> 25T	2A-2B	1.4	Soap, Powder	20-25	23B <sub>6</sub> 25X	1A-1B-1C	.9
Phosphate Disodium (See Sodium Phosphate)	--	--	--	--	Soapstone, Talc, Fine	40-50	45A <sub>100</sub> 45XY	1A-1B-1C	2.0
Phosphate Rock, Broken	75-85	80D <sub>3</sub> 36	2D	2.1	Soda Ash, Heavy	55-65	60B <sub>6</sub> 36	2D	1.0
Phosphate Rock, Pulverized	60	60B <sub>6</sub> 36	2D	1.7	Soda Ash, Light	20-35	28A <sub>40</sub> 36Y	2D	.8
Phosphate Sand	90-100	95B <sub>6</sub> 37	3D	2.0	Sodium Aluminate, Ground	72	72B <sub>6</sub> 36	2D	1.0
Plaster of Paris (See Gypsum)	--	--	--	--	Sodium Aluminum Fluoride (See Kryolite)	--	--	--	--
Plumbago (See Graphite)	--	--	--	--	Sodium Aluminum Sulphate*	75	75A <sub>100</sub> 36	2D	1.0
Polystyrene Beads	40	40B <sub>6</sub> 35PQ	1B	4	Sodium Bentonite (See Bentonite)	--	--	--	--
Polyvinyl Chloride Powder	20-30	25A <sub>100</sub> 45KT	2B	1.0	Sodium Bicarbonate (See Baking Soda)	--	--	--	--
Polyvinyl Chloride Pellets	20-30	25E45KPQT	1B	.6	Sodium Chloride (See Salt)	--	--	--	--
Polyethylene, Resin Pellets	30-35	33C <sub>1/2</sub> 45Q	1A-1B	4	Sodium Carbonate (See Soda Ash)	--	--	--	--
Potash (Muriate) Dry	70	70B <sub>6</sub> 37	3D	2.0	Sodium Hydrate (See Caustic Soda)	--	--	--	--
Potash (Muriate) Mine Run	75	75D <sub>3</sub> 37	3D	2.2	Sodium Hydroxide (See Caustic Soda)	--	--	--	--
Potassium Carbonate	51	51B <sub>6</sub> 36	2D	1.0	Sodium Borate (See Borax)	--	--	--	--
Potassium Chloride Pellets	120-130	125C <sub>1/2</sub> 25TU	3D	1.6	Sodium Nitrate	70-80	75D <sub>3</sub> 25NS	2A-2B	1.2
Potassium Nitrate - 1/2"	76	76C <sub>1/2</sub> 16NT	3D	1.2	Sodium Phosphate	50-60	55A35	1A-1B	.9
Potassium Nitrate - 1/4"	80	80B <sub>6</sub> 26NT	3D	1.2	Sodium Sulfate (See Salt Cake)	--	--	--	--
Potassium Sulfate	42-48	45B <sub>6</sub> 46X	2D	1.0	Sodium Sulfite	96	96B <sub>6</sub> 46X	2D	1.5
Potato Flour	48	48A <sub>200</sub> 35MNP	1A-1B	.5	Sorghum, Seed (See Kafir or Milo)	--	--	--	--
Pumice - 1/8"	42-48	45B <sub>6</sub> 46	3D	1.6	Soybean, Cake	40-43	42D <sub>3</sub> 35W	2A-1B-1C	1.0
Pyrite, Pellets	120-130	125C <sub>1/2</sub> 26	3D	2.0	Soybean, Cracked	30-40	35C <sub>1/2</sub> 36NW	2D	.5
Quartz, - 100 Mesh	70-80	75A <sub>100</sub> 27	3D	1.7	Soybean, Flake, Raw	18-25	22C <sub>1/2</sub> 35Y	1A-1B-1C	.8
Quartz, - 1/2"	80-90	85C <sub>1/2</sub> 27	3D	2.0	Soybean, Flour	27-30	29A <sub>40</sub> 35MN	1A-1B-1C	.8
Rice, Bran	20	20B <sub>6</sub> 35NY	1A-1B-1C	4	Soybean Meal, Cold	40	40B <sub>6</sub> 35	1A-1B-1C	.5
Rice, Grits	42-45	44B <sub>6</sub> 35P	1A-1B-1C	4	Soybean Meal, Hot	40	40B <sub>6</sub> 35T	2A-2B	.5
Rice, Polished	30	30C <sub>1/2</sub> 15P	1A-1B-1C	4	Soybeans, Whole	45-50	48C <sub>1/2</sub> 26NW	--	1.0
Rice, Hulled	45-49	47C <sub>1/2</sub> 25P	1A-1B-1C	4	Starch	25-50	38A <sub>40</sub> 15M	1A-1B-1C	1.0
Rice, Hulls	20-21	21B <sub>6</sub> 35NY	1A-1B-1C	4	Steel Turnings, Crushed	100-150	125D <sub>3</sub> 46WV	3D	3.0
Rice, Rough	32-36	34C <sub>1/2</sub> 35N	1A-1B-1C	6	Sugar Beet, Pulp, Dry	12-15	14C <sub>1/2</sub> 26	2D	.9
Rosin - 1/2"	65-68	67C <sub>1/2</sub> 45Q	1A-1B-1C	1.5	Sugar Beet, Pulp, Wet	25-45	35C <sub>1/2</sub> 35X	1A-1B-1C	1.2
Rubber, Reclaimed Ground	23-50	37C <sub>1/2</sub> 45	1A-1B-1C	.8	Sugar, Refined, Granulated Dry	50-55	53B <sub>6</sub> 35PU	1B	1.0-1.2
Rubber, Pelleted	50-55	53D <sub>3</sub> 45	2A-2B-2C	1.5	Sugar, Refined, Granulated Wet	55-65	60C <sub>1/2</sub> 35X	1B	1.4-2.0
Rye	42-48	45B <sub>6</sub> 15N	1A-1B-1C	4	Sugar, Powdered	50-60	55A <sub>100</sub> 35PX	1B	.8
Rye Bran	15-20	18B <sub>6</sub> 35Y	1A-1B-1C	4	Sugar, Raw	55-65	60B <sub>6</sub> 35PX	1B	1.5
Rye Feed	33	33B <sub>6</sub> 35N	1A-1B-1C	5	Sulphur, Crushed, - 1/2"	50-60	55C <sub>1/2</sub> 35N	1A-1B	.8
Rye Meal	35-40	38B <sub>6</sub> 35	1A-1B-1C	5	Sulphur, Lumpy, - 3"	80-85	83D <sub>3</sub> 35N	2A-2B	.8
Rye Middlings	42	42B <sub>6</sub> 35	1A-1B	5	Sulphur, Powdered	50-60	55A <sub>40</sub> 35MN	1A-1B	.6
Rye, Shorts	32-33	33C <sub>1/2</sub> 35	2A-2B	.5	Sunflower Seed	19-38	29C <sub>1/2</sub> 15	1A-1B-1C	.5
Safflower, Cake	50	50D <sub>3</sub> 26	2D	.6	Talcum, - 1/2"	80-90	85C <sub>1/2</sub> 36	2D	.9
Safflower, Meal	50	50B <sub>6</sub> 35	1A-1B-1C	.6	Talcum Powder	50-60	55A <sub>200</sub> 36M	2D	.8
Safflower Seed	45	45B <sub>6</sub> 15N	1A-1B-1C	.4	Tanbark, Ground*	55	55B <sub>6</sub> 45	1A-1B-1C	.7
Saffron (See Safflower)	--	--	--	--	Timothy Seed	36	36B <sub>6</sub> 35NY	1A-1B-1C	.6
Sal Ammoniac (Ammonium Chloride)	--	--	--	--	Titanium Dioxide (See Ilmenite Ore)	--	--	--	--
Salt Cake, Dry Coarse	85	85B <sub>6</sub> 36TU	3D	2.1	Tobacco, Scraps	15-25	20D <sub>3</sub> 45Y	2A-2B	.8
Salt Cake, Dry Pulverized	65-85	75B <sub>6</sub> 36TU	3D	1.7	Tobacco, Snuff	30	30B <sub>6</sub> 45MQ	1A-1B-1C	.9
Salicylic Acid	29	29B <sub>6</sub> 37U	3D	.6	Tricalcium Phosphate	40-50	45A <sub>40</sub> 45	1A-1B	1.6
Salt, Dry Coarse	45-60	53C <sub>1/2</sub> 36TU	3D	1.0	Triple Super Phosphate	50-55	53B <sub>6</sub> 36RS	3D	2.0
Salt, Dry Fine	70-80	75B <sub>6</sub> 36TU	3D	1.7	Trisodium Phosphate	60	60C <sub>1/2</sub> 36	2D	1.7
Saltpeper - (See Potassium Nitrate)	--	--	--	--	Trisodium Phosphate Granular	60	60B <sub>6</sub> 36	2D	1.7
Sand Dry Bank (Damp)	110-130	120B <sub>6</sub> 47	3D	2.8	Trisodium Phosphate, Pulverized	50	50A <sub>40</sub> 36	2D	1.6
Sand Dry Bank (Dry)	90-110	100B <sub>6</sub> 37	3D	1.7	Tung Nut Meats, Crushed	28	28D <sub>3</sub> 25W	2A-2B	.8
Sand Dry Silica	90-100	95B <sub>6</sub> 27	3D	2.0	Tung Nuts	25-30	28D <sub>3</sub> 15	2A-2B	.7
Sand Foundry (Shake Out)	90-100	95D <sub>3</sub> 37Z	3D	2.6	Urea Prills, Coated	43-46	45B <sub>6</sub> 25	1A-1B-1C	1.2
Sand (Resin Coated) Silica	104	104B <sub>6</sub> 27	3D	2.0	Vermiculite, Expanded	16	16C <sub>1/2</sub> 35Y	1A-1B	.5
Sand (Resin Coated) Zircon	115	115A <sub>100</sub> 27	3D	2.3	Vermiculite, Ore	80	80D <sub>3</sub> 36	2D	1.0
Sawdust, Dry	10-13	12B <sub>6</sub> 45UX	1A-1B-1C	.7	Vetch	48	48B <sub>6</sub> 16N	1A-1B-1C	.4
Sea-Coal	65	65B <sub>6</sub> 36	2D	1.0	Walnut Shells, Crushed	35-45	40B <sub>6</sub> 36	2D	1.0
Sesame Seed	27-41	34B <sub>6</sub> 26	2D	.6	Wheat	45-48	47C <sub>1/2</sub> 25N	1A-1B-1C	.4
Shale, Crushed	85-90	88C <sub>1/2</sub> 36	2D	2.0	Wheat, Cracked	40-45	43B <sub>6</sub> 25N	1A-1B-1C	.4
Shellac, Powdered or Granulated	31	31B <sub>6</sub> 35P	1B	.6	Wheat, Germ	18-28	23B <sub>6</sub> 25	1A-1B-1C	.4
Silicon Dioxide (See Quartz)	--	--	--	--	White Lead, Dry	75-100	88A <sub>40</sub> 36MR	2D	1.0
Silica, Flour	80	80A <sub>40</sub> 46	2D	1.5	Wood Chips, Screened	10-30	20D <sub>3</sub> 45VY	2A-2B	.6
Silica Gel + 1/2"-3"	45	45D <sub>3</sub> 37HKQU	3D	2.0	Wood Flour	16-36	26B <sub>6</sub> 35N	1A-1B	.4
Slag, Blast Furnace Crushed	130-180	155D <sub>3</sub> 37Y	3D	2.4	Wood Shavings	8-16	12E45VY	2A-2B	1.5
Slag, Furnace Granular, Dry	60-65	63C <sub>1/2</sub> 37	3D	2.2	Zinc, Concentrate Residue	75-8	78B <sub>6</sub> 37	3D	1.0
Slate, Crushed, - 1/2"	80-90	85C <sub>1/2</sub> 36	2D	2.0	Zinc Oxide, Heavy	30-35	33A <sub>100</sub> 45X	1A-1B	1.0
					Zinc Oxide, Light	10-15	13A <sub>100</sub> 45XY	1A-1B	1.0

\*Consult Engineering Department.

REFERENCE TO SPECIFIC MATERIALS IN TABLE SHOULD NOT BE CONSTRUED AS INDICATING THAT ALL OF THE MATERIALS ARE RECOMMENDED FOR SCREW CONVEYOR APPLICATION.





# Capacity Charts

## How to Use Capacity Charts for Conveyor Size and Speed

1. Find your material class from material table (First letter & last two numbers). This determines trough loading.
2. Determine size by being at or less than maximum cubic feet per hour.
3. Exact conveyor speed is determined by dividing the required capacity in cubic feet per hour by cubic feet per hour at 1 revolution per minute.

EXAMPLE: from Page #10.

$$\frac{2,250}{19.4} = 115.9 \text{ or } 116 \text{ RPM conveyor speed}$$

116 RPM is below maximum RPM

4. Refer to Table No. 1, Sizes of Lumps to Diameter, page 9. If the required diameter shown on the Capacity Chart is smaller than the recommended size given in table No. 1, both the diameter and speed must be refigured.

**Note:** Data shown on this chart is for general information only. If in doubt consult our engineers for specific recommendations.

Table 7 Horizontal Screw Conveyor Capacity

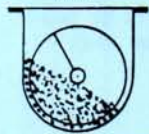
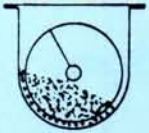
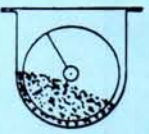
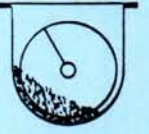
Material Class Code	Degree of Trough Loading	Screw Dia. Inch	Maximum RPM *	Capacity, Cubic Feet Per Hour	
				At Max. RPM	At One RPM
A-15 A-25 B-15 B-25 C-15 C-25	45% 	6 9 12 14 16 18 20 24	165 155 145 140 130 120 110 100	368 1270 2820 4370 6060 8120 10300 16400	2.23 8.2 19.4 31.2 46.7 67.6 93.7 164.0
A-35 E-35 A-45 E-45 B-35 B-45 C-35 C-45 D-15 D-25 D-35 D-45 E-15 E-25	Non-Abrasive Materials 30% A 	6 9 12 14 16 18 20 24	120 100 90 85 80 75 70 65	180 545 1160 1770 2500 3380 4370 7100	1.49 5.45 12.9 20.8 31.2 45.0 62.5 109.0
A-16 D-16 A-26 D-26 A-36 D-36 A-46 D-46 B-16 E-16 B-26 E-26 B-36 E-36 B-46 E-46 C-16 C-26 C-36 C-46	Abrasive Materials 30% B 	6 9 12 14 16 18 20 24	60 55 50 50 45 45 40 40	90 300 645 1040 1400 2025 2500 4360	1.49 5.45 12.9 20.8 31.2 45.0 62.5 109.0
A-17 D-17 A-27 D-27 A-37 D-37 A-47 D-47 B-17 E-17 B-27 E-27 B-37 E-37 B-47 E-47 C-17 C-27 C-37 C-47	15% 	6 9 12 14 16 18 20 24	60 55 50 50 45 45 40 40	45 150 325 520 700 1010 1250 2180	0.75 2.72 6.46 10.4 15.6 22.5 31.2 54.6

\*Maximum recommended R.P.M.



THE EXPERIENCE  
TO HANDLE IT RIGHT!™

# Screw Conveyor Corporation

Manufacturing Plants and Sales Offices: Winona, Mississippi; Visalia, California; Chanute, Kansas; Hammond, Indiana; Sales Office: Atlanta, Georgia





When selecting components for your Screw Conveyor, please refer to the basic layout diagram and accompanying table on page 17 for dimensional standards and recommended arrangements.

## SCREW CONVEYOR

Available as either right or left-hand. Right-hand conveyor screws will be supplied unless otherwise specified. See "HAND" OF CONVEYOR, Table No. 8. Use standard length conveyor screws wherever possible. The carrying side of the flighting surface that does the actual job of conveying is free of lugs. The back or non-carrying side of the flight is reinforced at the ends to guard against the flight folding back.

Table No. 8 "HAND" OF CONVEYOR

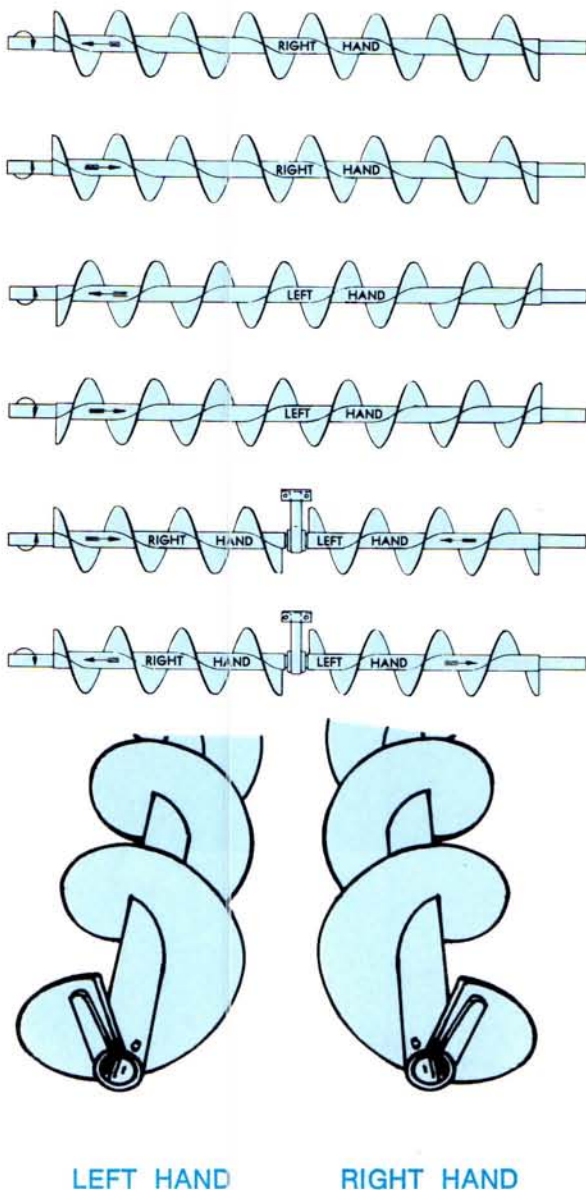

## COUPLINGS AND SHAFTS

Coupling, Drive and End shafts connect and transmit the rotary motion to the following conveyor screws.

It is of prime importance that the shafts selected be of sufficient strength to handle the expected horsepower load. See "Horsepower Rating", page 10.

Most conveyor systems are made of standard components, and, in order to replace or renew an intermediate section of conveyor, it is necessary to dismantle the conveyor unit from one end. By incorporating the Redi-Change feature (see page 30) a section can be easily removed from the center of the conveyor without starting from one end and dismantling the entire unit. This saves both time and labor.

## HANGERS

Hangers are used as an intermediate support between two sections of conveyor screw. They help maintain alignment and provide a bearing surface for the coupling shaft.

Hangers should be placed clear of inlet openings. They can be placed at trough joints and are designed with spacer bars wide enough for this purpose. Hangers may be fitted with a variety of bearing materials to suit many application requirements.

## TROUGH ENDS

Trough Ends support the conveyor screw and the trough and should utilize a thrust bearing. This bearing will hold the rotating conveyor screw in position. This provides for smoother operation, less required power and less wear on the hangers, bearings and other components. The standard duty "Chevron" or the heavy-duty "Hammond" will absorb thrust in either direction, although the preferred location of the drive is on the discharge end.

Seals are used in the trough ends to prevent leakage into or out of the trough. They also give added protection to the end bearings and shafts if abrasive or corrosive materials are being handled.

The shelf-type trough end is very often used when handling hot materials, so that the bearing and drive can be separated by some distance from the heated trough. They are also used for the handling of abrasive or very fine materials which require more effective seals than can be installed under flange bearings. The seal generally used is the split type or for more extreme applications, the pump type (page 45).

## TROUGHS AND COVERS

Troughs are available in several standard designs. Standard lengths should be used wherever possible. Differing styles are available for specific applications. When planning a conveyor which will use either "Barron" or "Tite-Seal" clamps, place the cover ends at points other than directly over the hangers. This will allow the grease fittings to be brought up through the cover without interfering with the cover clamps. Gasketing between the trough and the cover is available for dust-tight operation and is standard with either Barron or Tite-Seal covers.





# Design Data

## Material Input and Discharge

Care should be exercised in controlling the loading of the conveyor since it is designed to handle a specific maximum volume of material. Problems arise when the conveyor is charged from storage without the benefit of input volume controls. If the rate of material flow is not inherently self-regulating or cannot be regulated by other controls, it is advisable to incorporate a Screw Feeder into the system for handling the surge loads and to deliver a smooth, measured input to the Screw Conveyor.

Input is normally through a square opening cut in the cover but may be through specially built flared spouts designed to fit the bottom of a bin or other machinery. The opening should be kept well back from the nearest hanger to eliminate any possible choking at that point.

Discharge spouts may also be built to fit special machinery and may be flared or longer than standard.

The flighting is usually eliminated beyond the midpoint of the last discharge opening to affect complete discharge and reduce the possibility of material carryover. When conveying materials which roll easily, such as soy beans or easily aerated materials such as flour, it may be advisable to install longer than standard discharge spouts. Intermediate trough discharge spouts may be fitted with a variety of discharge control gates or slides. These slides are very often manually operated, although they can also be actuated by rack and pinion gates, hydraulic or pneumatic cylinders, or can be operated with a special electric gear motor complete with limit switches. It is recommended that the discharge spout of units with only one discharge, or the final discharge spout of units with multiple discharges be furnished without slide of any kind.

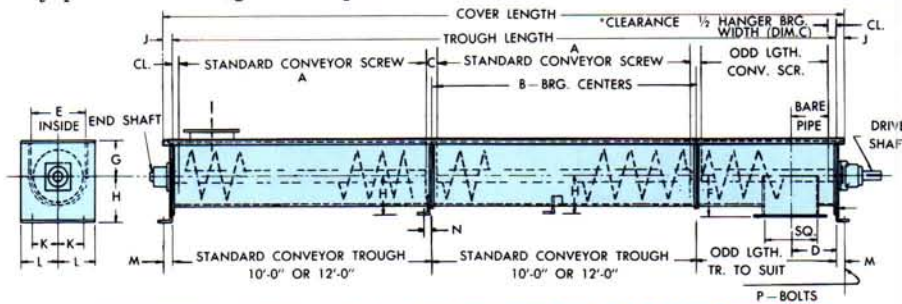

Table No. 9

### ASSEMBLY DATA AND RECOMMENDED ARRANGEMENTS

Conveyor Diameter Inches	Shaft and Coupling Diameter Inches	A	B	C	D	E	F	G	H	J	K	L	M	N	P
6	1½	9'-10	10'-0	2	6	7	5	4½	5½	1½	4¼	4¾	1	¾	¾
9	1½	9'-10	10'-0	2	8	10	7½	6½	7½	1¾	4¼	6¾	1½	1¾	½
10	2	9'-10	10'-0	2	8	10	7½	6½	7½	1¾	4¼	6¾	1½	1¾	½
	1½	9'-10	10'-0	2	9	11	7½	6½	8½	1¾	4¾	7¼	1¾	1¾	½
12	2	9'-10	10'-0	2	9	11	7½	6½	8½	1¾	4¾	7¼	1¾	1¾	½
	2	11'-10	12'-0	2	10½	13	8½	7¾	9½	2	6½	8¾	1¾	1¾	¾
14	2½	11'-9	12'-0	3	10½	13	8½	7¾	9½	2	6½	8¾	1¾	1¾	¾
	3	11'-9	12'-0	3	10½	13	8½	7¾	9½	2	6½	8¾	1¾	1¾	¾
16	2½	11'-9	12'-0	3	11½	15	10½	9¼	10½	2	6¾	9¾	1¾	1¾	¾
	3	11'-9	12'-0	3	11½	15	10½	9¼	10½	2	6¾	9¾	1¾	1¾	¾
18	3	11'-9	12'-0	3	13½	17	11½	10½	12	2½	7¾	10½	2	1¾	¾
	3	11'-9	12'-0	3	14½	19	12½	12½	13½	2½	8	12½	2	1¾	¾
20	3¾	11'-8	12'-0	4	14½	19	12½	12½	13½	2½	8	12½	2	1¾	¾
	3	11'-9	12'-0	3	15½	21	13½	13½	15	2½	9¾	13½	2¼	2	¾
24	3¾	11'-8	12'-0	4	15½	21	13½	13½	15	2½	9¾	13½	2¼	2	¾
	3¾	11'-8	12'-0	4	17½	25	15½	16½	18½	2½	10	15½	2½	2¼	¾

## Conveyor Match Marking

The term "Assemble, Fit and Match Mark" is commonly used when specifying individual conveyor assembly. It means that the subject conveyor will be assembled in our shop with all parts match marked before disassembly, painting and shipment. Assembly consists of putting together all conveyor parts and components to make a complete operable unit. The diagram below illustrates the method used to match mark a standard horizontal conveyor unit. Note that all major parts consisting of screws, troughs and covers are marked with the unit number. The assembly part numbers start at the feed or input end of the conveyor and run consecutively to the discharge end. All part numbers are placed at the joint connection of successive parts. Note also that all intermediate hangers are located and bolted in place. Otherwise this must be done in the field.

The conveyor unit is then disassembled and shipped with all couplings and coupling bolts in place in the screw. In

some instances, the screws are shipped in their troughs, although it is usually more practical to ship screws, troughs and covers as individual components. Smaller parts, such as hangers, conveyor trough assembly bolts and trough ends are marked with the unit number and separately bundled or boxed.



NOTE: MARKINGS ARE PLACED ON PIPE SIDES

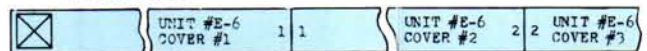

MATCH-MARK AND ASSEMBLY

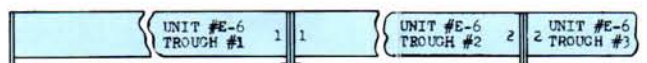

NOTE: MARKINGS BEGIN AT FEED END



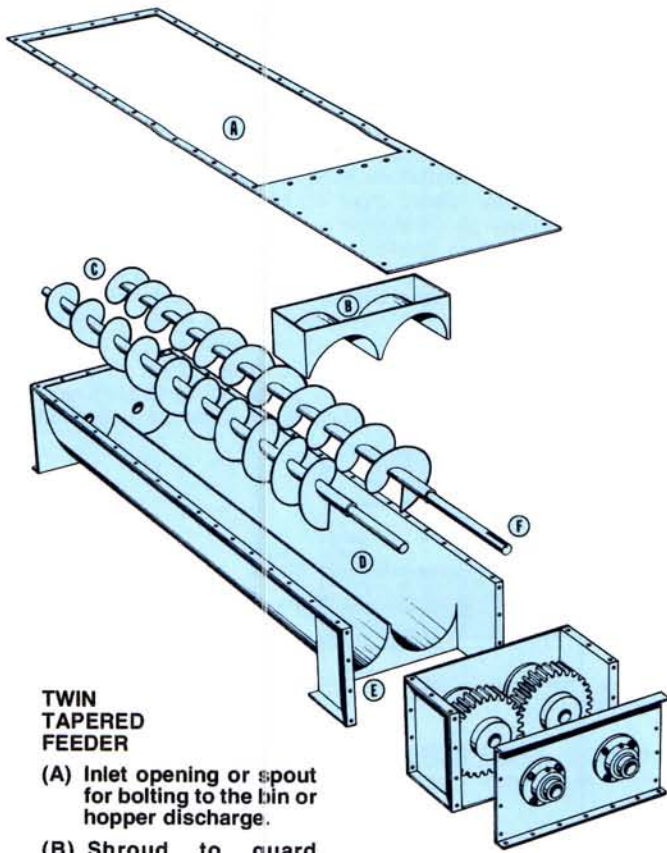

**TWIN  
TAPERED  
FEEDER**

- (A) Inlet opening or spout for bolting to the bin or hopper discharge.
- (B) Shroud to guard against material flooding.
- (C) Twin tapered screw conveyor permits even draw off of material for the length of the opening.
- (D) Twin-tapered trough.
- (E) Discharge spout.
- (F) Solid shafting transmits rotary motion to driving gears.
- (G) Driving gears synchronize the action of the screw conveyors.

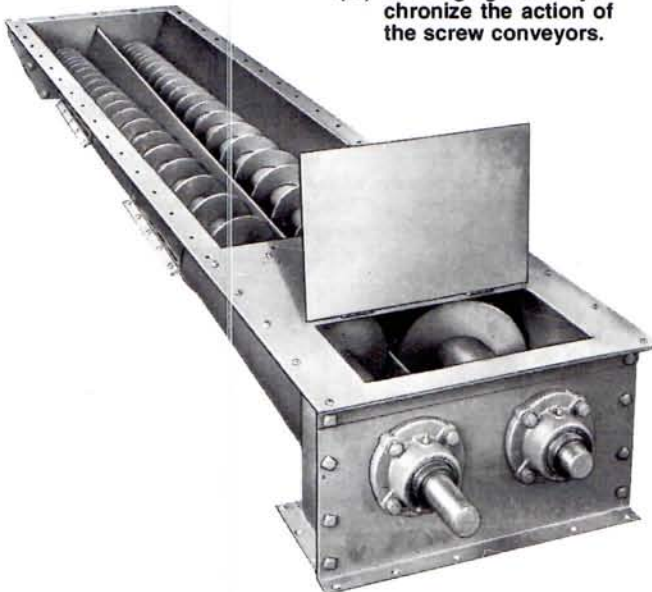

Normally short in length, Screw Feeders are designed to regulate the volumetric rate of material flow from a hopper, bin or storage unit.

The inlet must be flooded with material (100% load capacity) by incorporating changes in the construction of the flighting (diameter, pitch, etc.) and the speed of the feeder screw, the material discharge can be governed to the desired rate. Feeders can be built with variable diameter or stepped pitch or both in units composed of one, two or a multiple number of screws (ie., Live Bottom Bin) depending on the application. Long conveyors may be designed with special flights at the feed end for controlling the depth of the material to conform with the recommendations made in the Material Tables, pages 12, 13 and 14.

Screw Feeders are normally equipped with a shroud for a short distance beyond the inlet opening. This guards against flooding of the conveyor with material. When handling very free flowing materials, extended shroud covers, tubular housing construction or short pitch flights are occasionally required for positive control.

When under a choke load, screw feeders with uniform diameter and pitch normally convey the material from the rear of the inlet opening first. To draw off material evenly across the full length of the inlet, a tapered screw or stepped pitch conveyor screw is required.

While Screw Feeders are available in many designs to fit your particular requirements, several commonly used types are described below.



### Multiple Diameter Feeder

This is a combination feeder and conveyor and the physical dimensions are variable on each. The small diameter feed end will operate at a full cross-sectional load. When the material reaches the larger section, the cross-sectional load will reduce to a safe level.

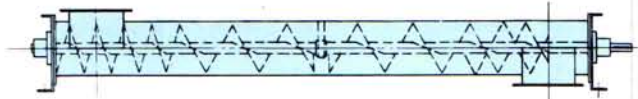

### Short Pitch Feeder

This is also a combination feeder and conveyor. The short pitch end will handle full cross-sectional loads. The material is then discharged into the standard section where the cross-sectional load is reduced in proportion to the increase in screw pitch. A section of double flight is pictured on the discharge end of this feeder. This creates a more even discharge from the conveyor.



2A-2B



# Selecting a Screw Feeder

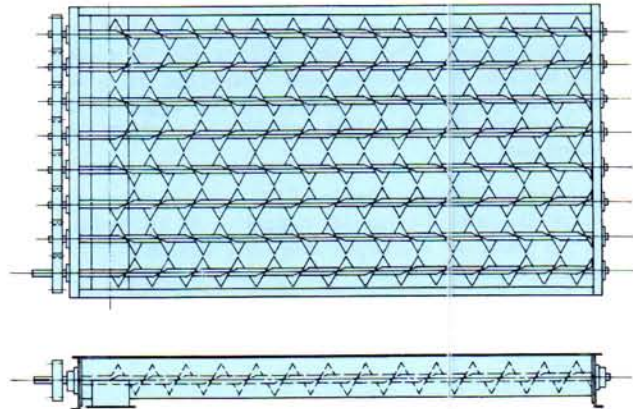
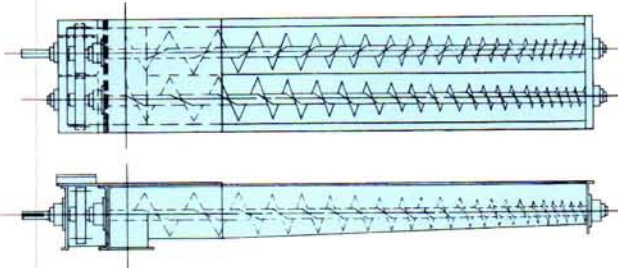

## Variable Pitch Twin-Tapered Feeder

This feeder is popularly used to unload bins or hoppers at a controlled rate. The feed opening under the bin is designed large enough to prevent material bridging and accepts materials uniformly across the length and width of the opening. This eliminates dead areas in the bin and reduces the chance of material bridging or spoiling.

## Live Bottom Feeder

Designed for use on straight sided bins, this feeder is composed of a number of feeder screws in tandem which serve as the bottom of the bin. Material is, therefore, drawn out equally from the full width. The Live Bottom Feeder is used to its best advantage on materials which tend to pack or bridge easily.

CAPACITY OF SCREW FEEDERS										
Table No. 10 Figures shown are theoretical capacities in cubic feet per hour per R.P.M. for standard pitch screws.										
Conveyor Diameter	Standard Pipe Sizes									
	1"	1 1/4"	1 1/2"	2"	2 1/2"	3"	3 1/2"	4"	5"	6"
4"	1.56	1.44	1.35							
6"			5.30	4.97	4.41					
9"			18.99	18.49	17.85	16.25				
10"			26.28	25.73	25.02	23.49				
12"				45.28	44.42	42.99	41.89			
14"					71.67	70.15	68.73	67.10		
16"						106.35	104.72	102.86		
18"						153.06	151.20	149.10	146.5	
20"							209.50	204.00	201.0	197.5
24"							366.40	363.60	356.4	348.6

The above figures are based on 100% of cross section of actual screw capacity and may be more or less depending upon the material. These figures must be corrected for pitches other than standard.

## Screw Feeder Capacity

The accompanying table No. 10 shows Screw Feeder capacities in cubic feet per hour per RPM. This table relates to full pitch or standard conveyors only. Shorter pitch flighting will convey a capacity in direct ratio to the capacity of the full pitch. For instance, a 9" conveyor with standard pitch (9") flighting on a 2 1/2" standard pipe will convey 17.85 cu. ft./hr./RPM. The same conveyor, but with 3" pitch, will convey 1/3 this amount, or 5.95 cu. ft./hr./RPM. The capacity figure is theoretical. Actual capacity will often vary due to variation in material characteristics as well as variations in diameter and pitch resulting from manufacturing tolerances.

## Screw Feeder Speed

The speed of the feeder screw can be determined by dividing the desired capacity in cu. ft./hr. by the figure found

in table No. 10. For maximum efficiency, feeder screw speeds should be slower than standard screw conveyor speeds and allowances must be made for slippage of the material in the screw.

### Factors Affecting The Design Of A Screw Feeder

1. The material class
2. The material physical characteristics, see page 11
3. The capacity required
4. Material Factor "F"
5. Weight of material resting on the Feeder Screw
6. The dimensions of the feeder opening

In designing a Screw Feeder, virtually every situation is unique in one respect or another. For this reason, we recommend that you consult our staff engineers for proper recommendations concerning your particular needs.





Screw Conveyors can be operated with the flow of material inclined upward. When space allows, this is a very economical method of elevating and conveying. It is important to understand, however, that as the angle of inclination increases, the allowable capacity of a given unit rapidly decreases.

A standard Screw Conveyor inclined 15° upward may only carry 75% of its rated horizontal capacity. At an inclination of 25°, a standard conveyor may only handle 50% of its horizontal capacity. These are estimated figures and will vary with the characteristic of the material being handled. Inclined Screw Conveyor capacities can be increased over short distances if no intermediate hangers are required.

Other aids in conveying on an incline are the use of shorter than standard pitch and/or tubular housings or shrouded conveyor trough covers. Very often it becomes necessary to use high speed to overcome the tendency of material to fall back.

The above aids are resorted to in order to overcome the tendency of a screw conveyor to become less efficient as the angle of incline increases. Vertical conveying by Screw Conveyor, on the other hand, is quite successful and it remains that a 45° incline or angles approaching this figure are the most difficult on which to achieve successful conveying.

Inclined conveyors can seldom be used as metering feeders. If an accurate flow is necessary, a separate horizontal feeder conveyor is required.

Additional power is needed to convey on an incline. This added power is a function of the power required to lift the material. Judgment and experience in the art of conveying are required. Again we suggest you contact our Engineering Department for specific recommendations.

Tubular Trough and Half Pitch Screw Conveyor.

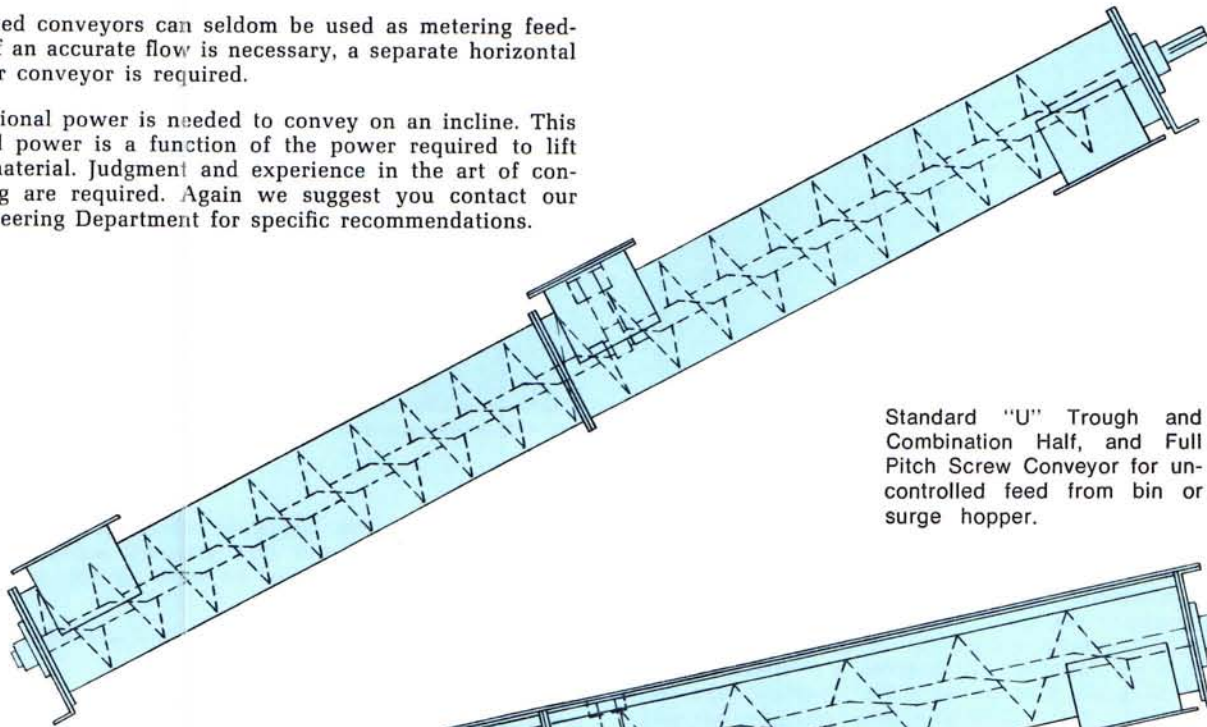

Standard "U" Trough and Combination Half, and Full Pitch Screw Conveyor for uncontrolled feed from bin or surge hopper.

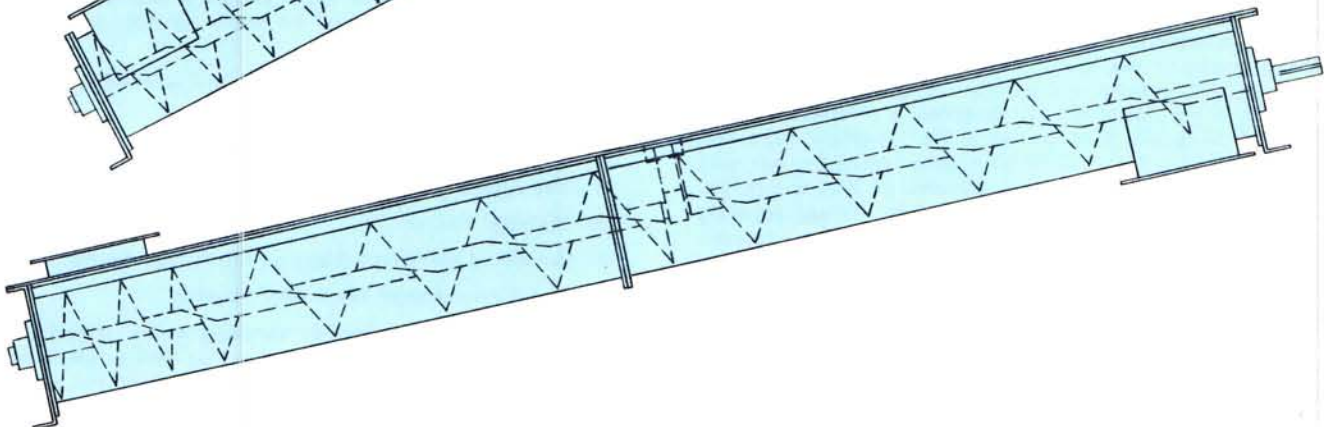



# Typical Drive Assemblies

Screw conveyor drives are available in a wide variety of use in transmitting the necessary rotary motion to the screw. Integral or fractional horsepower motors can be coupled with many different types of gear reducers which, in turn, are directly connected to the screw through a coupling, roller chain or V-belt. Most types of drives provide a constant output speed but variable speed designs may be utilized for particular applications. Both constant or variable speed hydraulic drives are also available.

The typical drive arrangement pictured utilizes a modified shaft mount reducer complete with V-belt drive and motor mount. In this assembly, the reducer output shaft, conveyor thrust bearing, end seal and trough end are combined into one complete screw conveyor drive unit. Four different mounting assemblies are available (see below) and variations on these are available to fit virtually all possible requirements. The reducer output shaft bearings, in this case, take the place of the conveyor thrust bearing. A shaft seal adequate for most dust applications between the conveyor and the reducer is also provided.

Other types of drives available are:

1. Electric gearmotor combination with roller chain drive.
2. Gear reducer connected through roller chain to the screw conveyor. V-belts or couplings connect the reducer input shaft and the motor.
3. Variable speed controlled D.C. motors with any of several types of reducers.
4. Hydraulic drives.
5. Variable pitch pulleys between motor and reducer including the flange mount type pictured.

We do not recommend a direct coupling connection motor to reducer to conveyor. This allows no adjustment in conveyor speed which may sometimes be necessary due to manufacturing tolerances or changes in requirements.

## Guards and Chain Casings

Chain casings and guards are fabricated of heavy gauge steel and then are split and hinged for ease of access and installation. All moving parts are totally enclosed to protect both workmen and equipment. When drives are located out of reach of personnel they can often be considered "guarded by location" and complete enclosures may not be necessary.

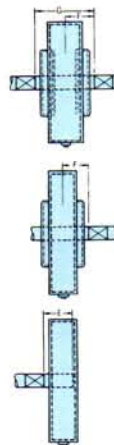
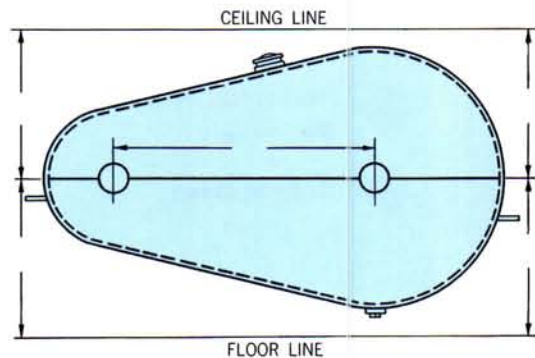
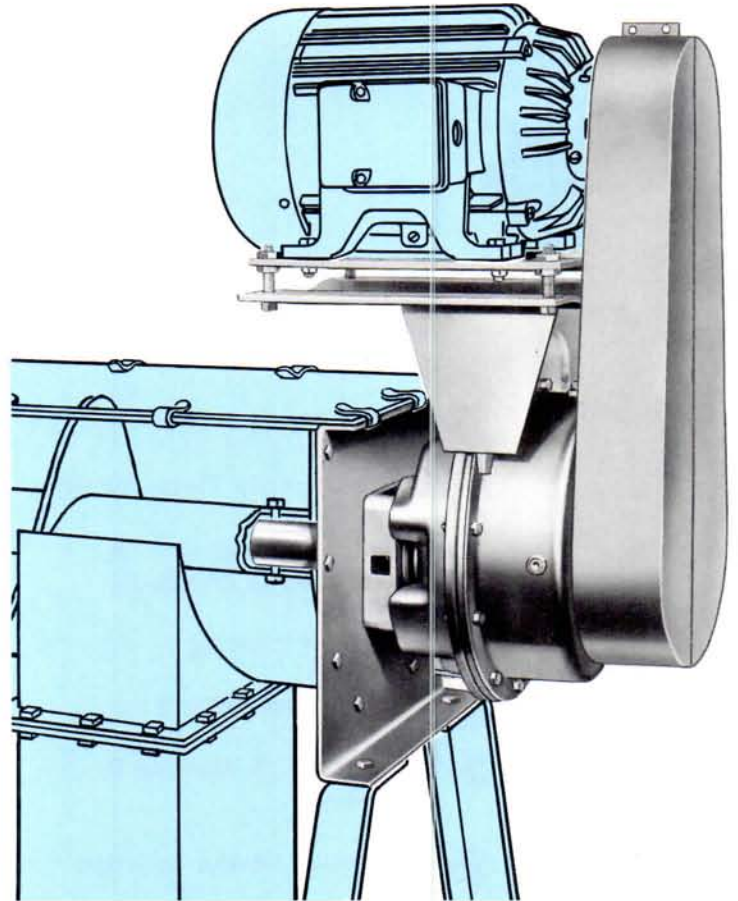
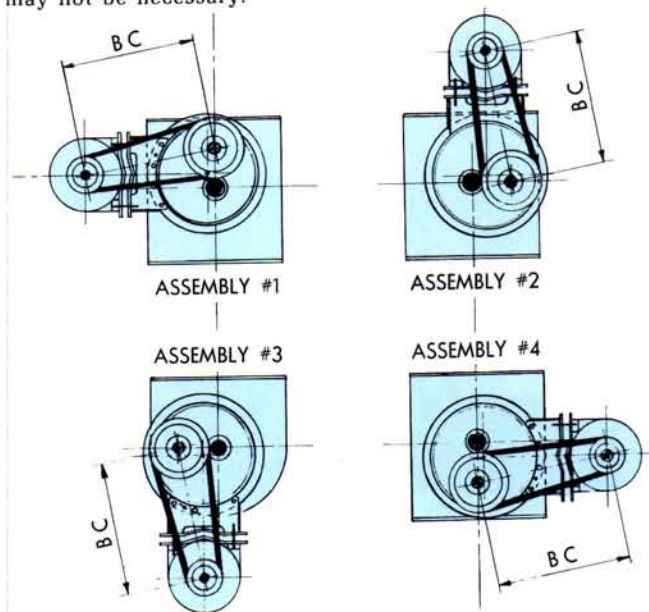

**Type A casing** is recommended for use on unusual operations where the extra precautions are required, such as on outdoor installations where water, dust or dirt are a problem. The double oil seals at all shaft openings insure the retention of the lubricant even under high speeds.

**Type B casing** is recommended for general drive installations involving moderate speeds. Single oil seals are provided at all shaft openings and are suitable for drip type lubrication.

**Type C casing** serves mainly as a safety guard. In addition, it provides the moving parts with protection against dirt and foreign objects.

**Type A and B casings** are usually considered roller chain guards.

**Type C casing** is usually considered as a V-belt guard.





# The Screw-Lift®

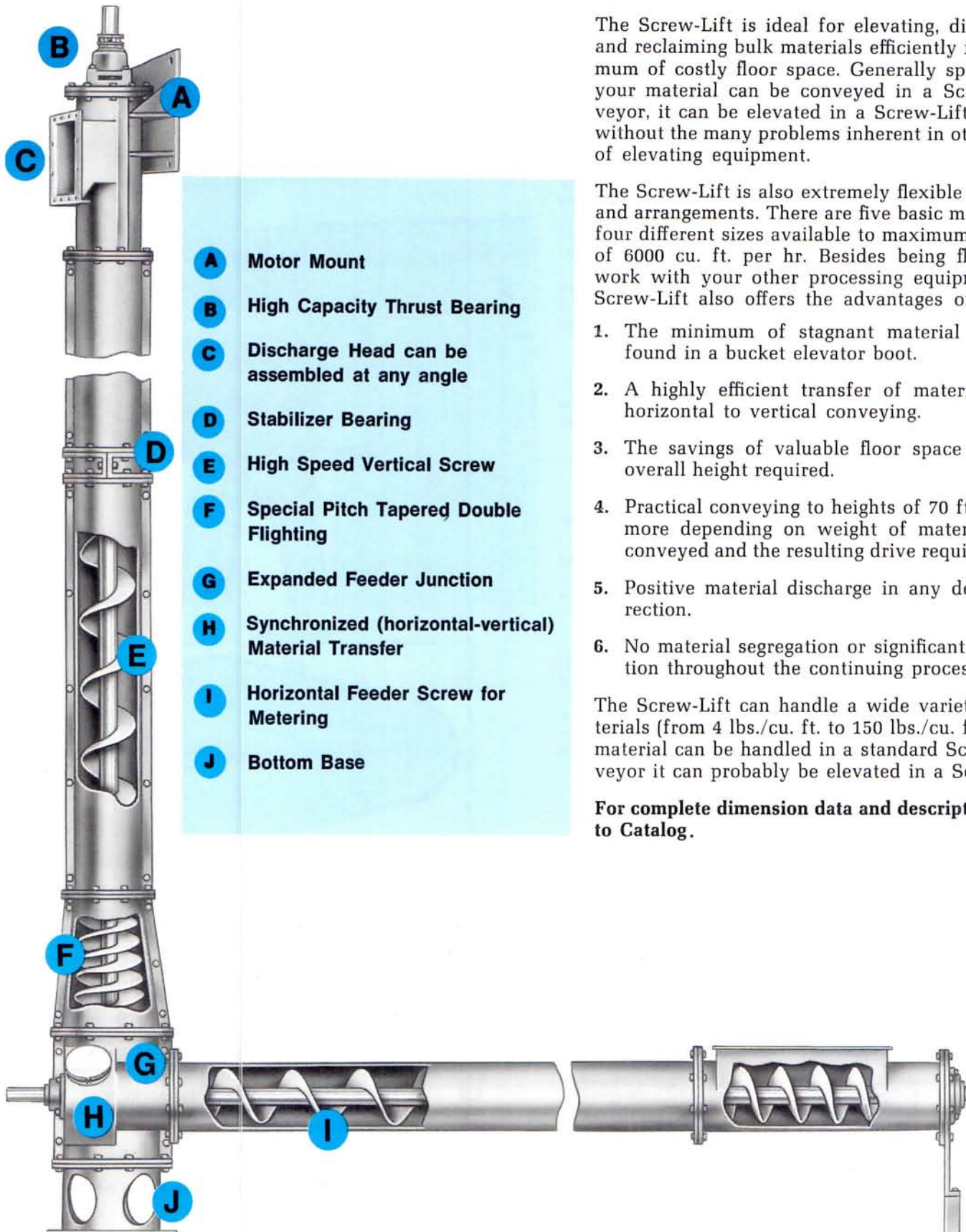

- A** Motor Mount
- B** High Capacity Thrust Bearing
- C** Discharge Head can be assembled at any angle
- D** Stabilizer Bearing
- E** High Speed Vertical Screw
- F** Special Pitch Tapered Double Flighting
- G** Expanded Feeder Junction
- H** Synchronized (horizontal-vertical) Material Transfer
- I** Horizontal Feeder Screw for Metering
- J** Bottom Base

The Screw-Lift is ideal for elevating, distributing and reclaiming bulk materials efficiently in a minimum of costly floor space. Generally speaking, if your material can be conveyed in a Screw Conveyor, it can be elevated in a Screw-Lift . . . and without the many problems inherent in other types of elevating equipment.

The Screw-Lift is also extremely flexible in design and arrangements. There are five basic models and four different sizes available to maximum capacity of 6000 cu. ft. per hr. Besides being flexible to work with your other processing equipment, the Screw-Lift also offers the advantages of:

1. The minimum of stagnant material as often found in a bucket elevator boot.
2. A highly efficient transfer of materials from horizontal to vertical conveying.
3. The savings of valuable floor space and less overall height required.
4. Practical conveying to heights of 70 ft. or even more depending on weight of material being conveyed and the resulting drive requirement.
5. Positive material discharge in any desired direction.
6. No material segregation or significant degradation throughout the continuing process.

The Screw-Lift can handle a wide variety of materials (from 4 lbs./cu. ft. to 150 lbs./cu. ft.). If the material can be handled in a standard Screw Conveyor it can probably be elevated in a Screw-Lift.

**For complete dimension data and description, refer to Catalog.**





# The Screw-Lift® Principle

The Screw-Lift is not just a Screw Conveyor turned on end; it is a combination of standard design parts integrated into one machine for a particular application. This machine operates as a completely closed system carrying a relatively low cross-sectional load of material. It utilizes the centrifugal force generated by the high speed of its vertical screw to actually elevate the material. It does not merely extrude the material upwards by jamming more material in behind. In fact, it is designed to insure against jamming, choking and back-pressure. This provides highly efficient operation and minimizes crushing or degradation of friable materials.

## STANDARD DESIGN

Inside the expanded feeder junction, the material flow is changed from the horizontal to the vertical direction. The lower portion of the vertical Screw is a special pitch tapered double flight which starts the material moving upwards away from the feeder. These features eliminate back-pressure, choking and material degradation and are standard on all Screw-Lifts.

Also standard on all Screw-Lifts is the use of conveyor screw with precision internal collars fitted in each end. Coupling bolt holes are jig-drilled to assure positive alignment. Split Stabilizer Bearings keep the conveyor and its housing concentric at all times while offering a minimum of resistance to material flow. This provides for a smooth, quiet running unit—even when empty. The standard design of the stabilizer bearing incorporates high density polyethylene. Special bushing material such as canvas base phenolic, self-lubricating bronze with graphite inserts, graphited cast iron, nylon or standard bronze is available.

The Screw-Lift housing is made in four to six foot lengths for ease of assembly and maintenance. It is then split and flanged vertically for accessibility as well as strength and rigidity. The closely held tolerance of  $\frac{1}{4}$ " clearance between the inside of the housing and the screw minimizes material build-up and facilitates clean-out.

Although normally made of carbon steel, Screw-Lifts that handle corrosive materials may be made of stainless steels or other highly resistant metal, or may be hot dipped galvanized. Surface-hardening (fusing an alloy to the fighting surface for protection against abrasion) is also available.

Where sanitation or change of product requires frequent cleaning, the Quick-Opening type Screw-Lift is recommended. Heavy-duty, quick-release clamps make opening the casing fast and easy while gaskets seal the unit for commercially dust-tight operation.

## ESTABLISH THE REQUIRED CAPACITY

Under normal conditions, the Screw-Lift will handle the capacities shown at the given speeds.

Table No. 11

Screw-Lift Diameter, Inches	Nominal Rated Capacity Cu. Ft. Per Hour	Screw-Lift Input Speed RPM
6"	300	300
9"	1000	250
12"	2500	250
16"	6000	190

## ESTABLISH THE REQUIRED HORSEPOWER

The formula listed below gives the basic horsepower (HP) required for an operating Screw-Lift. Additional power will be required for starting under load and for overcoming any power loss in the drive assembly or in erection misalignment.

$$HP = \frac{7 QLF}{1,000,000} + C$$

Q = Pounds per hour at maximum capacity

L = Screw-Lift height in feet

F = Material H.P. factor from table, pages 12, 13 and 14

C = 1.0 for Types "E", "G" and "H"

1.3 for Types "C" and "J"

## SAMPLE PROBLEM

Establish the Screw-Lift specifications for elevating 25,000 lbs. of soybean meal per hour. The required lift height is 45' and the horizontal feeder length required is 10'.

## SOLUTION

Refer to the material table No. 6, pages 12 and 13. Note: Soybean Meal average weight per cu. ft. = 40 lbs.

Material class = B26 = (Fine —  $\frac{1}{8}$  inch mesh and under,

Free-flowing — angle of repose  $30^\circ$  to  $45^\circ$  Non-abrasive).  
HP Factor .5

Now, dividing 25,000 lbs. per hour, by 40 lbs. per cu. ft., we find the required capacity is 625 cu. ft. per hour. Referring to the Screw-Lift Capacity Chart, we find that a 9" diameter unit will handle this load. By using a horizontal feeder screw under the bottom of the mixer, we will be able to exercise control and so limit the capacity to 625 cu. ft./hr. rather than the maximum that a 9" unit can handle (1,000 cu. ft./hr.). The power requirements can now be figured:

$$HP = \frac{7.0 \times 25,000 \times 45 \times .5}{1,000,000} + 1.3 = 5.3$$

A  $7\frac{1}{2}$  HP 900 RPM motor with Vee Belt reduction to 250 RPM screw speed is suggested.

Presuming the popular Type G unit (as pictured) is being used, the feeder is driven separately. The feeder drive is calculated as a normal horizontal Screw Conveyor from the formula shown on page 9.





# Dimensional Data and Descriptions

The component section which follows is designed to give you complete dimensional data as well as individual product descriptions so that you may select the exact components to fit your particular needs.

In addition, this section augments the Engineering and Layout sections of this catalog. It is recommended that the basic layout diagram and accompanying table be referred to when selecting components for complete units. See page 17.

We have all the pieces to put together an answer to your bulk material conveying problem. Screw conveyors handle almost any bulk material efficiently and they do it economically compared to other methods. Compact, they fit into tight places, with moving parts inclosed. They're easy to install and simple to maintain. You can run them horizontally, on an incline, and, with our Screw-Lift, straight up.

We will furnish screw conveyors for you, in component parts or complete systems, with features such as automatic lock nuts at conveyor screw connections, jig-drilling of component parts for easy assembly, double flange troughs, latest designs in cover clamps, bearing materials most suitable to your application and many more Screw Conveyor specialties.

We can meet your application needs in helicoid and sectional flight types with adaptations including ribbon, special pitches and tapered — in various gauges of steel, stainless steel and other alloys, including hardened flight surfaces.

Whether your need is for components or a complete system, you can rely on our years of experience as specialists in the engineering and manufacturing of screw conveyors. Consult our specialist engineers without obligation.

## Safety Precautions

Since in its usual application a screw conveyor is enclosed, it is fundamentally a "safe machine". However, as with any power operated equipment, certain precautions should be exercised to insure that the natural safety provisions of a conveyor assembly are utilized. A conveyor assembly and drive is for the most part custom designed to fulfill its application, therefore, the provisions to insure a safe installation will differ from transaction to transaction.

- (1) A conveyor must not be put under power until the trough and cover is in place and secured and power transmission guards in place and closed.
- (2) If the conveyor cover or housing is to be opened, the motor must first be locked out electrically in such a way that it can not be restarted by anyone either in the vicinity or remote from the conveyor.
- (3) If, because of its application, the conveyor must have open housing, then the entire conveyor must be separated from personnel areas by a fence and warning signs posted.

- (4) Open feed hoppers or spouts for shovel, front end loader or other manual or mechanical loading must incorporate a grating. If the characteristics of the material being handled is such that a grating can not be used, then the exposed portion of the conveyor must be guarded by a fence and warning signs posted.
  - (5) Electrical controls, machinery guards, walkways, machinery arrangement, training of personnel, etc., are all necessary considerations in the creation of a safe, practical installation and are generally not a part of our services. It is the responsibility of the Contractor, Installer, Owner, and User to supplement the materials furnished by Screw Conveyor Corporation to result in a safe conveyor installation and to comply with the Williams-Steiger Occupational Safety and Health Act, state or local laws and ordinances, and the American National Standard Institute Safety Code.
- This is a full size facsimile of the adhesive sticker attached at time of shipment to all Screw Conveyor troughs.*

**⚠ WARNING**



**Lock out power before removing cover or guard.**

**Do not step on cover or guard.**





# Helicoid Conveyor Screws

**DIMENSIONS IN INCHES AND AVERAGE WEIGHTS IN POUNDS**

Dia. of Screw	Size Code	Length of Std. Section	Std. Length Mounted Conveyor			Std. Length Flighting Only			Thickness of Flight		Nominal Pipe I.D.	Outside Dia. of Pipe	Dia. of Coupling "A"
			Part No. Right Hand	Part No. Left Hand	Weight Per Section	Part No. Right Hand	Part No. Left Hand	Weight Per Section	Next to Pipe "B"	Outer Edge "C"			
4"	4H204	9'10 1/2"	101-0214	111-0212	31	120-0146	125-0141	9.0	1/8	1/16	1 1/4	1 5/8	1
4"	4H206	9'10 1/2"	101-0354	111-0352	38	120-0211	125-0216	16.0	3/16	3/32	1 1/4	1 5/8	1
6"	6H304	9'10"	101-0420	111-0428	50	120-0286	125-0281	14.0	1/8	1/16	2	2 3/8	1 1/2
6"	6H308	9'10"	101-0495	111-0493	64	120-0351	125-0356	28.0	1/4	1/8	2	2 3/8	1 1/2
6"	6H312	9'10"	101-0560	111-0568	78	120-0427	125-0422	42.0	3/8	3/16	2	2 3/8	1 1/2
9"	9H306	9'10"	101-0636	111-0634	70	120-0567	125-0497	31.0	3/16	3/32	2	2 3/8	1 1/2
9"	9H312	9'10"	101-0701	111-0709	101	120-0633	125-0562	62.0	3/8	3/16	2	2 3/8	1 1/2
9"	9H406	9'10"	101-0776	111-0774	91	120-0708	125-0638	30.0	3/16	3/32	2 1/2	2 7/8	2
9"	9H412	9'10"	101-0842	111-0840	121	120-0773	125-0703	60.0	3/8	3/16	2 1/2	2 7/8	2
9"	9H414	9'10"	101-0917	111-0915	131	120-0849	125-0778	70.0	7/16	7/32	2 1/2	2 7/8	2
10"	10H306	9'10"	101-0982	111-0980	81	120-0914	125-0844	42.0	3/16	3/32	2	2 3/8	1 1/2
10"	10H412	9'10"	101-1055	111-1053	130	120-0989	125-0919	69.0	3/8	3/16	2 1/2	2 7/8	2
12"	12H408	11'10"	101-1121	111-1129	140	120-1052	125-0984	67.0	1/4	1/8	2 1/2	2 7/8	2
12"	12H412	11'10"	101-1196	111-1194	175	120-1128	125-1057	102.0	3/8	3/16	2 1/2	2 7/8	2
12"	12H508	11'9"	101-1261	111-1269	168	120-1193	125-1123	64.0	1/4	1/8	3	3 1/2	2 7/16
12"	12H512	11'9"	101-1337	111-1335	200	120-1268	125-1198	96.0	3/8	3/16	3	3 1/2	2 7/16
12"	12H614	11'9"	101-1402	111-1400	216	120-1334	125-1263	112.0	7/16	7/32	3 1/2	4	3
14"	14H508	11'9"	101-1477	111-1475	170	120-1409	125-1339	84.0	1/4	1/8	3	3 1/2	2 7/16
14"	14H614	11'9"	101-1543	111-1541	236	120-1474	125-1404	132.0	7/16	7/32	3 1/2	4	3
16"	16H610	11'9"	101-1618	111-1616	228	120-1540	125-1479	120.0	5/16	5/32	3 1/2	4	3
16"	16H614	11'9"	101-1758	111-1756	267	120-1680	125-1610	163.0	7/16	7/32	4	4 1/2	3
18"	18H610	11'9"	101-1899	111-1897	292	120-1755	125-1685	144.0	5/16	5/32	4	4 1/2	3
20"	20H610	11'9"	101-1949	111-1947	298	120-1854	125-1701	150.0	5/16	5/32	4	4 1/2	3

● The pitch of flighting approximately equals conveyor diameter.  
 ▲ For convenience in specifying listed Helicoid Conveyor Screw, Size Codes have been established to designate the type of Conveyor Screw and flighting, pipe and coupling shaft specifications. The figure at the left of the letter indicates the diameter of the Conveyor Screw, the letter H (for Helicoid) designates the type; the first figure following the letter is twice the coupling diameter and the last two figures the nominal thickness of the flighting at the outer edge in 1/64".

■ When ordering, specify whether right or left hand, also length desired. Example: 9H306 RH - 9'10" or 9H306 RH - 5'6".  
 Consult us for Helicoid Conveyor Screws with heavy pipe or special coupling diameters.

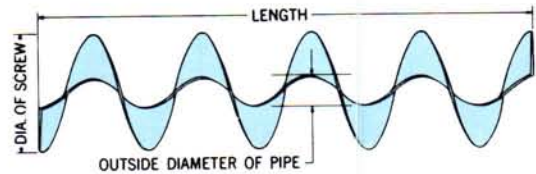
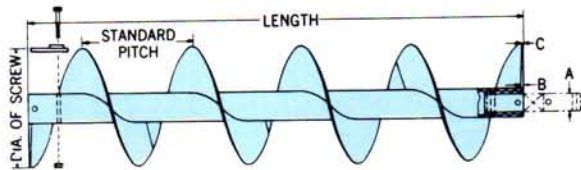

Cold rolling of special analysis strip steel into a continuous helix produces a work-hardened, smoothly finished flighting surface. Helicoid flighting is of superior strength with its diameter, pitch and thickness closely controlled. The flighting is then normally fastened to the pipe by intermittent welds and welded steel end lugs. They may be continuously welded on either one or both sides. The pipe has seamless internal collars inserted in both ends of the pipe to accommodate the shafts. Helicoid and Sectional flighting of the same diameter and shaft size are interchangeable. Refer to pages 30 through 33 for special features available on helicoid conveyor screws.

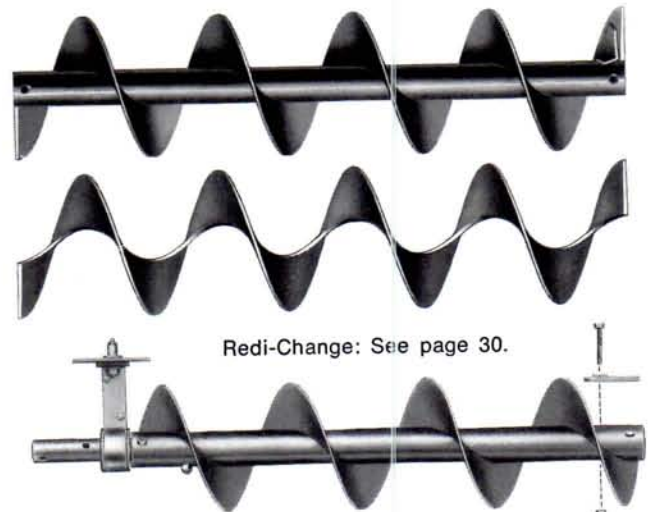

Redi-Change: See page 30.





# Sectional Flight Conveyor Screws

## DIMENSIONS IN INCHES AND AVERAGE WEIGHTS IN POUNDS

Diameter of Conveyor	† Size Code	Length of Standard Section	Part No. Right Hand	Part No. Left Hand	Diameter of Coupling "A"	Gauge or Thickness of Flights "B"	Pipe Size Standard Weight	Weight Per Section	Length of Hanger Bearings
• 6	6S307	9'10"	104-0146	114-0144	1½	12	2	61	2
• 6	6S309	9'10"	104-0211	114-0219	1½	10	2	64	2
• 6	6S312	9'10"	104-0286	114-0284	1½	3/16	2	73	2
6	6S316	9'10"	104-0351	114-0359	1½	¼	2	84	2
• 9	9S307	9'10"	104-0427	114-0425	1½	12	2	69	2
• 9	9S309	9'10"	104-0492	114-0490	1½	10	2	77	2
• 9	9S312	9'10"	104-0567	114-0565	1½	3/16	2	89	2
9	9S316	9'10"	104-0633	114-0631	1½	¼	2	107	2
• 9	9S407	9'10"	104-0708	114-0706	2	12	2½	89	2
• 9	9S409	9'10"	104-0773	114-0771	2	10	2½	98	2
• 9	9S412	9'10"	104-0849	114-0847	2	3/16	2½	109	2
• 9	9S416	9'10"	104-0914	114-0912	2	¼	2½	123	2
9	9S424	9'10"	104-0955	114-0953	2	3/8	2½	151	2
• 10	10S309	9'10"	104-0989	114-0987	1½	10	2	84	2
10	10S312	9'10"	104-1052	114-1050	1½	3/16	2	100	2
• 10	10S412	9'10"	104-1128	114-1126	2	3/16	2½	118	2
• 12	12S409	11'10"	104-1193	114-1191	2	10	2½	135	2
• 12	12S412	11'10"	104-1268	114-1266	2	3/16	2½	158	2
12	12S416	11'10"	104-1334	114-1332	2	¼	2½	185	2
• 12	12S509	11'9"	104-1409	114-1407	27/16	10	3	160	3
• 12	12S512	11'9"	104-1474	114-1472	27/16	3/16	3	180	3
12	12S516	11'9"	104-1540	114-1548	27/16	¼	3	205	3
12	12S524	11'9"	104-1615	114-1613	27/16	3/8	3	260	3
• 12	12S612	11'9"	104-1680	114-1688	3	3/16	3½	195	3
• 12	12S616	11'9"	104-1755	114-1753	3	¼	3½	218	3
12	12S624	11'9"	104-1821	114-1829	3	3/8	3½	269	3
• 14	14S509	11'9"	104-1896	114-1894	27/16	10	3	173	3
14	14S512	11'9"	104-1961	114-1969	27/16	3/16	3	200	3
• 14	14S612	11'9"	104-2035	114-2033	3	3/16	3½	213	3
• 14	14S616	11'9"	104-2100	114-2108	3	¼	3½	245	3
14	14S624	11'9"	104-2175	114-2173	3	3/8	3½	308	3
• 16	16S609	11'9"	104-2241	114-2249	3	10	3½	195	3
• 16	16S612	11'9"	104-2316	114-2314	3	3/16	3½	222	3
• 16	16S616	11'9"	104-2381	114-2389	3	¼	3½	258	3
16	16S624	11'9"	104-2456	114-2454	3	3/8	3½	326	3
16	16S632	11'9"	104-2522	114-2520	3	½	3½	398	3
18	18S612	11'9"	104-2597	114-2595	3	3/16	3½	244	3
18	18S616	11'9"	104-2662	114-2660	3	¼	3½	286	3
18	18S624	11'9"	104-2738	114-2736	3	3/8	3½	370	3
18	18S632	11'9"	104-2803	114-2801	3	½	3½	454	3
18	18S712	11'8"	104-2878	114-2876	37/16	3/16	4	264	4
18	18S716	11'8"	104-2944	114-2942	37/16	¼	4	303	4
18	18S724	11'8"	104-3017	114-3015	37/16	3/8	4	380	4
18	18S732	11'8"	104-3082	114-3080	37/16	½	4	460	4





# Sectional Flight Conveyor Screws

DIMENSIONS IN INCHES AND AVERAGE WEIGHTS IN POUNDS (Continued)									
Diameter of Conveyor	Size Code	Length of Standard Section	Part Number Right Hand	Part Number Left Hand	Diameter of Coupling "A"	Gauge or Thickness of Flights "B"	Pipe Size Standard Weight	Weight Per Section	Length of Hanger Bearings
20	20S612	11'9"	104-3157	114-3155	3	3/16	3 1/2	258	3
20	20S616	11'9"	104-3223	114-3221	3	1/4	3 1/2	314	3
20	20S624	11'9"	104-3298	114-3296	3	3/8	3 1/2	398	3
20	20S632	11'9"	104-3363	114-3361	3	1/2	3 1/2	489	3
20	20S712	11'8"	104-3439	114-3437	3 7/16	3/16	4	277	4
20	20S716	11'8"	104-3504	114-3502	3 7/16	1/4	4	323	4
20	20S724	11'8"	104-3579	114-3577	3 7/16	3/8	4	410	4
20	20S732	11'8"	104-3645	114-3643	3 7/16	1/2	4	500	4
24	24S712	11'8"	104-3710	114-3718	3 7/16	3/16	4	325	4
24	24S716	11'8"	104-3785	114-3783	3 7/16	1/4	4	385	4
24	24S724	11'8"	104-3850	114-3858	3 7/16	3/8	4	505	4
24	24S732	11'8"	104-3926	114-3924	3 7/16	1/2	4	625	4

■ The pitch of flights is approximately equal to the conveyor diameter on all listed specifications see page 32 for special pitch suggestions.

\* For convenience in specifying listed Sectional Flight conveyor screw, Size Codes have been established to designate the type of conveyor screw, flights, pipe and coupling shaft specifications. The figure to the left of the letter indicates the diameter of the conveyor screw, the letter "S" (for Sectional Flight) designates the type; the first figure following the letter is twice the coupling diameter and the last two figures the thickness of the flights.

† When ordering, specify whether right or left hand, also length desired. Example: 12S624 RH - 11'9" or 12S624 LH - 13'3 1/2"

● We suggest use of corresponding specifications in Helicoid Conveyor, which can be supplied from stock. We can manufacture Sectional Flight conveyor screws with any special feature desired, such as special diameter, pitch, thickness of flight, pipe size, tubing, solid shaft, etc. Consult us.

Each flight is blanked from a steel plate, formed into a helix and then butt welded together. Sectional flights are formed with a lead longer than their pitch to assure a tight gripping action along the pipe. The flights are then normally fastened to the pipe by intermittent welds and welded steel end lugs. They may be continuously welded on either one or both sides. The pipe has seamless internal collars in each end to accommodate the shafts. Sectional Flight conveyor screws are available in special diameters, thicknesses, pitches and pipe sizes. They also can be obtained in stainless steel, Monel, brass, copper and other metals.

See pages 30 through 33 for special features available on all conveyor screws.

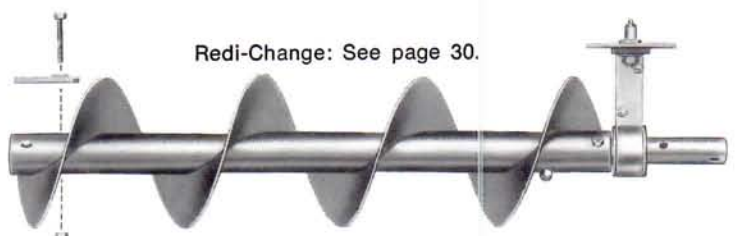
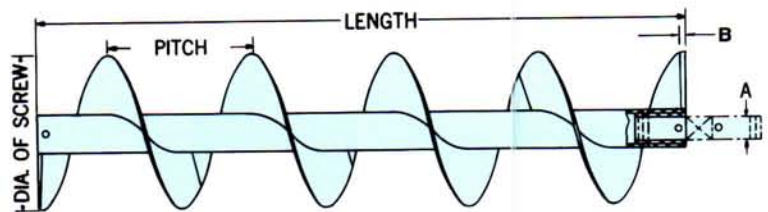





# Flights for Sectional Conveyor Screws

## DIMENSIONS IN INCHES AND AVERAGE WEIGHTS IN POUNDS

Dia. "A"	Pipe Size	Pipe O.D. "B"	Gauge "C"	STANDARD PITCH				HALF PITCH				Dia. "A"	Pipe Size	Pipe O.D. "B"	Gauge "C"	STANDARD PITCH				HALF PITCH								
				Size* Code	Part No Right Hand	Part No Left Hand	Pitch	Wgt.	Size* Code	Part No Right Hand	Part No Left Hand					Pitch	Wgt.	Size* Code	Part No. Right Hand	Part No. Left Hand	Pitch	Wgt.	Size* Code	Part No. Right Hand	Part No. Left Hand	Pitch	Wgt.	
6	2	2 1/2	12	6F307	130-0284	135-0289	6	1.0	6F307H	131-0218	136-0213	3	9	14	3 1/2	4	1/16	14F612	130-2876	135-2806	14	9.5	14F612H	131-2594	136-2243	7	7.8	
6	2	2 1/2	10	6F309	130-0359	135-0354	6	1.3	6F309H	131-0283	136-0288	3	1.1	14	3 1/2	4	1/8	14F616	130-2942	135-2871	14	12.7	14F616H	131-2669	136-2318	7	10.5	
6	2	2 1/2	3/16	6F312	130-0425	135-0420	6	1.8	6F312H	131-0358	136-0353	3	1.5	14	3 1/2	4	3/16	14F624	130-3015	135-2947	14	19.0	14F624H	131-2735	136-2383	7	15.7	
6	2	2 1/2	1/4	6F316	130-0490	135-0485	6	2.4	6F316H	131-0424	136-0429	3	2.1	16	3 1/2	4	1/4	16F609	130-3296	135-3226	16	9.7	16F609H	131-2800	136-2458	8	8.3	
9	2	2 1/2	12	9F307	130-0631	135-0636	9	2.5	9F307H	131-0564	136-0494	4 1/2	2.0	16	3 1/2	4	1/16	16F612	130-3361	135-3291	16	13.0	16F612H	131-2875	136-2524	8	11.0	
9	2	2 1/2	10	9F309	130-0706	135-0701	9	3.3	9F309H	131-0630	136-0569	4 1/2	2.7	16	3 1/2	4	1/8	16F616	130-3437	135-3366	16	17.5	16F616H	131-2941	136-2599	8	15.0	
9	2	2 1/2	3/16	9F312	130-0771	135-0776	9	4.4	9F312H	131-0705	136-0635	4 1/2	3.6	16	3 1/2	4	3/16	16F624	130-3502	135-3432	16	26.0	16F624H	131-3014	136-2664	8	22.5	
9	2	2 1/2	1/4	9F316	130-0847	135-0842	9	6.0	9F316H	131-0770	136-0700	4 1/2	5.0	16	3 1/2	4	1/2	16F632	130-3577	135-3507	16	35.0	16F632H	131-3089	136-2730	8	30.0	
9	2 1/2	2 1/2	12	9F407	130-1050	135-1055	9	2.4	9F407H	131-0986	136-0841	4 1/2	1.9	18	3 1/2	4	3/16	18F612	130-3643	135-3572	18	18.0	18F612H	131-3220	136-2870	9	14.1	
9	2 1/2	2 1/2	10	9F409	130-1126	135-1121	9	3.2	9F409H	131-1059	136-0916	4 1/2	2.6	18	3 1/2	4	1/8	18F616	130-3718	135-3648	18	24.0	18F616H	131-3295	136-2946	9	18.8	
9	2 1/2	2 1/2	3/16	9F412	130-1191	135-1186	9	4.2	9F412H	131-1125	136-0981	4 1/2	3.4	18	3 1/2	4	3/16	18F624	130-3783	135-3713	18	36.0	18F624H	131-3360	136-3019	9	28.2	
9	2 1/2	2 1/2	1/4	9F416	130-1266	135-1261	9	5.5	9F416H	131-1190	136-1054	4 1/2	4.5	18	3 1/2	4	1/2	18F632	130-3858	135-3788	18	48.0	18F632H	131-3436	136-3084	9	37.6	
9	2 1/2	2 1/2	3/8	9F424	130-1332	135-1295	9	8.4	9F424H	131-1232	136-1088	4 1/2	6.8	18	4	4 1/2	3/16	18F712	130-3924	135-3853	18	17.0	18F712H	131-3501	136-3159	9	13.0	
10	2	2 1/2	10	10F309	130-1472	135-1402	10	3.9	10F309H	131-1265	136-1120	5	3.3	18	4	4 1/2	1/4	18F716	130-3999	135-3929	18	22.5	18F716H	131-3576	136-3225	9	17.5	
10	2	2 1/2	3/16	10F312	130-1548	135-1477	10	5.3	10F312H	131-1331	136-1195	5	4.5	18	4	4 1/2	3/8	18F724	130-4062	135-3994	18	33.5	18F724H	131-3642	136-3290	9	27.0	
10	2 1/2	2 1/2	3/8	10F412	130-1613	135-1543	10	5.0	10F412H	131-1406	136-1260	5	4.2	18	4	4 1/2	1/2	18F732	130-4138	135-4067	18	45.0	18F732H	131-3717	136-3365	9	38.0	
12	2 1/2	2 1/2	10	12F409	130-1753	135-1618	12	5.8	12F409H	131-1547	136-1336	6	4.7	20	3 1/2	4	3/16	20F612	130-4203	135-4133	20	20.0	20F612H	131-3782	136-3431	10	17.5	
12	2 1/2	2 1/2	3/16	12F412	130-1829	135-1683	12	7.5	12F412H	131-1612	136-1401	6	6.4	20	3 1/2	4	3/8	20F624	130-4344	135-4273	20	40.0	20F624H	131-3923	136-3571	10	34.5	
12	2 1/2	2 1/2	1/4	12F416	130-1894	135-1758	12	10.0	12F416H	131-1687	136-1476	6	8.7	20	3 1/2	4	1/2	20F632	130-4419	135-4349	20	53.0	20F632H	131-3998	136-3647	10	46.0	
12	3	3 1/2	10	12F509	130-2033	135-1899	12	5.4	12F509H	131-1828	136-1542	6	4.8	20	4	4 1/2	3/16	20F712	130-4559	135-4489	20	19.0	20F712H	131-4061	136-3712	10	17.0	
12	3	3 1/2	3/16	12F512	130-2108	135-1964	12	7.2	12F512H	131-1893	136-1617	6	6.2	20	4	4 1/2	1/4	20F716	130-4625	135-4554	20	25.5	20F716H	131-4137	136-3787	10	20.5	
12	3	3 1/2	1/4	12F516	130-2173	135-2038	12	9.6	12F516H	131-1968	136-1682	6	8.5	20	4	4 1/2	3/8	20F724	130-4690	135-4620	20	38.0	20F724H	131-4202	136-3852	10	32.5	
12	3	3 1/2	3/8	12F524	130-2249	135-2103	12	14.4	12F524H	131-2032	136-1757	6	12.8	20	4	4 1/2	1/2	20F732	130-4765	135-4695	20	51.0	20F732H	131-4277	136-3928	10	44.0	
12	3 1/2	4	3/16	12F612	130-2314	135-2244	12	7.0	12F612H	131-2172	136-1823	6	6.0	24	4	4 1/2	3/16	24F712	130-4831	135-4760	24	30.0	24F712H	131-4343	136-3993	12	26.0	
12	3 1/2	4	1/4	12F616	130-2389	135-2319	12	9.1	12F616H	131-2248	136-1898	6	8.0	24	4	4 1/2	1/4	24F716	130-4906	135-4836	24	40.0	24F716H	131-4418	136-4066	12	34.0	
12	3 1/2	4	3/8	12F624	130-2454	135-2384	12	13.7	12F624H	131-2313	136-1963	6	12.1	24	4	4 1/2	3/8	24F724	130-4971	135-4901	24	60.0	24F724H	131-4483	136-4132	12	51.0	
14	3	3 1/2	10	14F509	130-2595	135-2525	14	7.3	14F509H	131-2453	136-2102	7	6.5	24	4	4 1/2	1/2	24F732	130-5044	135-4976	24	80.0	24F732H	131-4558	136-4207	12	68.0	
14	3	3 1/2	3/16	14F512	130-2660	135-2590	14	9.9	14F512H	131-2529	136-2177	7	8.5															

\*Size Code follow those indicated for Sectional Flight Screw Conveyor on pages 27 and 28, except the first letter "F" indicates "Flight" and the suffix letter "H" indicates "Half-Pitch". Example: 12F62 RH or 12F624H RH. The "RH" indicates Right Hand Flights.

Sectional flights are formed from steel plate with a lead slightly longer than their pitch. This assures a tight gripping action when mounted on your pipe. When ordering flights from the table above please specify part number and hand of screw. See page 16. When ordering special flights, please specify pipe or shaft size, pitch, diameter, hand and thickness.

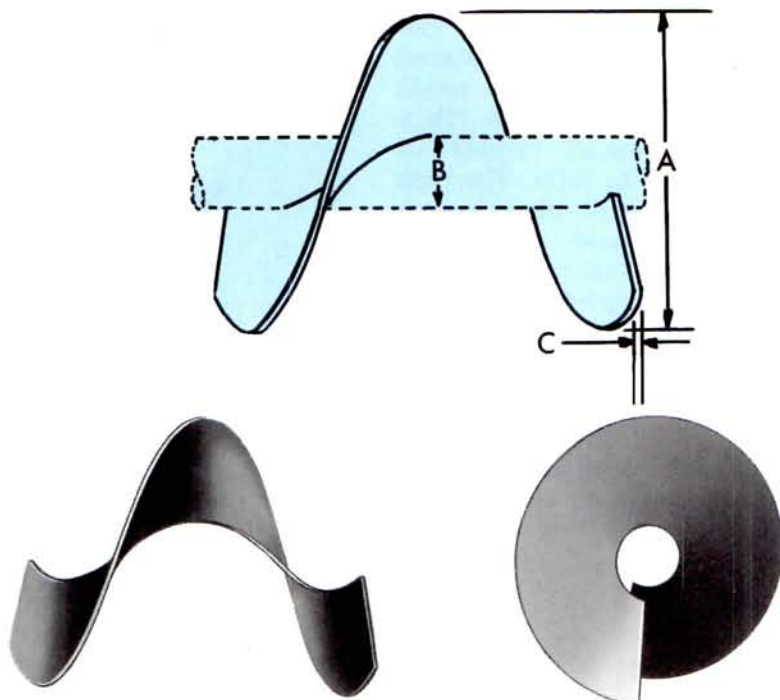





# Ribbon Conveyor Screws

DIMENSIONS IN INCHES AND AVERAGE WEIGHTS IN POUNDS													
Dia. of Screw	Size Code	Length of Standard Section	STANDARD MOUNTED CONVEYOR			STANDARD FLIGHTING ONLY			Thickness of Flight "C"	Width of Flight "D"	Pipe Size Nominal Pipe I.D.	Outside Diameter of Pipe	Diameter of Coupling "A"
			Part No. Right Hand	Part No. Left Hand	Weight Per Section	Part No. Right Hand	Part No. Left Hand	Weight Per Flight					
6	6R312	9'10"	106-0144	116-0142	60	132-0142	137-0147	2.0	3/16	1	2	2 3/8	1 1/2
9	9R316	9'10"	106-0219	116-0217	100	132-0217	137-0212	5.0	1/4	1 1/2	2	2 3/8	1 1/2
10	10R316	9'10"	106-0284	116-0282	110	132-0282	137-0287	6.0	1/4	1 1/2	2	2 3/8	1 1/2
12	12R416	11'10"	106-0359	116-0357	180	132-0357	137-0352	9.6	1/4	2	2 1/2	2 7/8	2
12	12R424	11'10"	106-0425	116-0423	204	132-0423	137-0428	12.0	3/8	2 1/2	2 1/2	2 7/8	2
12	12R524	11'9"	106-0490	116-0498	240	132-0498	137-0493	12.0	3/8	2 1/2	3	3 1/2	2 7/16
14	14R524	11'9"	106-0565	116-0563	264	132-0563	137-0568	14.4	3/8	2 1/2	3	3 1/2	2 7/16
14	14R624	11'9"	106-0631	116-0639	288	132-0597	137-0592	14.4	3/8	2 1/2	3 1/2	4	3
16	16R616	11'9"	106-0706	116-0704	264	132-0639	137-0634	12.0	1/4	2 1/2	3 1/2	4	3
16	16R624	11'9"	106-0771	116-0779	324	132-0704	137-0709	18.0	3/8	2 1/2	3 1/2	4	3
18	18R624	11'9"	106-0847	116-0845	360	132-0779	137-0774	24.6	3/8	3	3 1/2	4	3
20	20R724	11'8"	106-0912	116-0910	408	132-0845	137-0840	28.2	3/8	3	4	4 1/2	3 7/16
24	24R724	11'8"	106-0987	116-0985	468	132-0910	137-0915	37.2	3/8	3	4	4 1/2	3 7/16

\*For convenience in specifying, listed Ribbon Flight Conveyor Screw Part Numbers have been established to designate the type of Conveyor Screw flights, pipe and gudgeon specifications.

†When ordering Ribbon Flight Conveyor Screw specify Part Number, whether right or left hand and length desired. Example: 16R616 RH-11'9" or 16R616 RH-3'4".

When ordering Ribbon Conveyor Screw Flighting specify as above except add "Flighting Only."

\*Horsepower is directly proportional to speed predicated on specified coupling and bolts.

Ribbon conveyor screws are often used in mixing applications, however, their prime application is handling sticky or gummy materials which normally collect where the flights join the pipe. The open design of a ribbon conveyor screw minimizes this problem. When handling dry materials, mixing action results if the cross-sectional load is larger than the face of the flight (dimension D). The ribbon flights are fastened to the pipe by "Nu-Weld" lugs which eliminate the necessity of drilling fastening holes in the mounting pipe and, therefore, assure you of a stronger unit. The pipe has seamless internal collars in each end. Ribbon flight conveyor screws are available in many sizes and specifications other than listed in the table and are available in various materials, stainless steel, Monel, etc. See pages 30 through 33 for special features available on all conveyor screws.

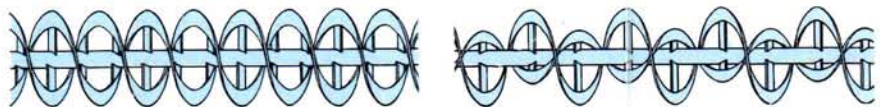
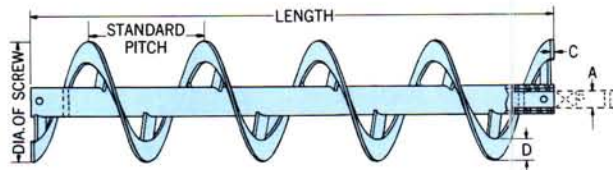

Used to handle sticky materials, the double flight ribbon conveyor screw also provides a more even discharge.

Double flight ribbon mixing conveyor screws consist of an outer ribbon conveyor screw with a smaller diameter inner ribbon of the opposite hand. The pitch of the inner and outer screws is the same. This design moves the material back and forth imparting a thorough mixing action while conveying.





# Special Designs Available on All Conveyor Screws



Simply disconnect the REDI-CHANGE section — clamping keys and hanger.



Lift the conveyor section out and perform necessary replacement or repairs.

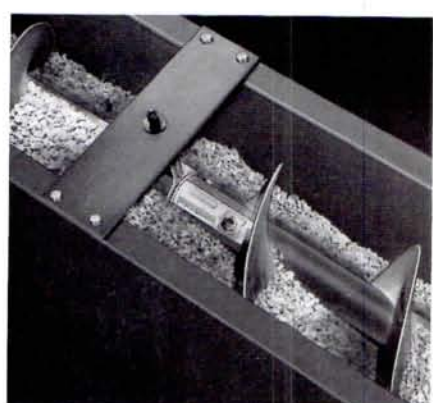

Replace the conveyor section, bolt the REDI-CHANGE clamping key in place and you are back in production with minimum downtime and expense!

## Redi-Change Quick Disconnect Conveyor Screws

The Redi-Change feature allows you to perform conveyor screw changes and repairs without dismantling the entire conveyor. The Redi-Change clamping key is bolted to one end of the conveyor pipe. By disconnecting the Redi-Change section — unbolting the clamping keys and hanger — a complete conveyor section can be lifted out without disturbing any preceding sections. To replace the section, bolt the Redi-Change clamping keys and the hanger in place and you are back in production.

The Redi-Change feature is available on all types of conveyor screws. Although normally supplied with the Redi-Change clamping key in only one end, conveyor sections with a clamping key in both ends are available on request. When assembling the conveyor, place the end with the Redi-Change clamping key nearest the drive end. This will eliminate any need to remove the drive unit for conveyor repairs. When ordering a screw conveyor with the Redi-Change quick disconnect coupling, specify Redi-Change part numbers. Part numbers are for standard length conveyor screw with clamping key on one end.

### REDI-CHANGE CONVEYOR SCREW PART NUMBERS

HELICOID CONVEYOR SCREW		
Size Code	Part Number Right Hand	Part Number Left Hand
6CH304	103-0147	113-0145
6CH308	103-0212	113-0210
6CH312	103-0287	113-0285
9CH306	103-0352	113-0350
9CH312	103-0428	113-0426
9CH406	103-0493	113-0491
9CH412	103-0568	113-0566
9CH414	103-0634	113-0632
10CH306	103-0709	113-0707
10CH412	103-0774	113-0772
12CH408	103-0840	113-0848
12CH412	103-0915	113-0913
12CH508	103-0980	113-0988
12CH512	103-1053	113-1051
12CH614	103-1129	113-1127
14CH508	103-1194	113-1192
14CH614	103-1269	113-1267
16CH610	103-1335	113-1333
16CH614	103-1400	113-1408
18CH610	103-1475	113-1473
20CH610	103-1533	113-1531

RIBBON CONVEYOR SCREW		
Size Code	Part Number Right Hand	Part Number Left Hand
6CR312	109-4275	111-8215
9CR316	109-4283	111-8223
10CR316	109-4291	111-8231
12CR416	109-4309	111-8249
12CR424	109-4317	111-8256
12CR524	109-4325	111-8264
14CR524	109-4333	111-8272
14CR624	109-4341	111-8280
16CR616	109-4358	111-8298
16CR624	109-4366	111-8306
18CR624	109-4374	111-8314
20CR724	109-4382	111-8322
24CR724	109-4390	111-8330

SECTIONAL CONVEYOR SCREW		
Size Code	Part Number Right Hand	Part Number Left Hand
6CS307	105-0145	115-0143
6CS309	105-0210	115-0218
6CS312	105-0285	115-0283
6CS316	105-0350	115-0358
9CS307	105-0426	115-0424
9CS309	105-0491	115-0499
9CS312	105-0566	115-0564
9CS316	105-0632	115-0630
9CS407	105-0707	115-0705
9CS409	105-0772	115-0770
9CS412	105-0848	115-0846
9CS416	105-0913	115-0911
9CS424	105-0954	115-0952
10CS309	105-0988	115-0986
10CS312	105-1051	115-1059
10CS412	105-1127	115-1125
12CS409	105-1192	115-1190
12CS412	105-1267	115-1265
12CS416	105-1333	115-1331
12CS509	105-1408	115-1406
12CS512	105-1473	115-1471
12CS516	105-1549	115-1547
12CS524	105-1614	115-1612
12CS612	105-1689	115-1687
12CS616	105-1754	115-1752
12CS624	105-1820	115-1828
14CS509	105-1895	115-1893
14CS512	105-1960	115-1968
14CS612	105-2034	115-2032
14CS616	105-2109	115-2107
14CS624	105-2174	115-2172
16CS609	105-2240	115-2248
16CS612	105-2315	115-2313
16CS616	105-2380	115-2388
16CS624	105-2455	115-2453
16CS632	105-2521	115-2529
18CS612	105-2596	115-2594
18CS616	105-2661	115-2669
18CS624	105-2737	115-2735
18CS632	105-2802	115-2800
18CS712	105-2877	115-2875
18CS716	105-2943	115-2941
18CS724	105-3016	115-3014
18CS732	105-3081	115-3089
20CS612	105-3156	115-3154
20CS616	105-3222	115-3220
20CS624	105-3297	115-3295
20CS632	105-3362	115-3360
20CS712	105-3438	115-3436
20CS716	105-3503	115-3501
20CS724	105-3578	115-3576
20CS732	105-3644	115-3642
24CS712	105-3719	115-3717
24CS716	105-3784	115-3782
24CS724	105-3859	115-3857
24CS732	105-3925	115-3923







# Special Designs Available on All Conveyor Screws

## Additional Types of Abrasion Resistant Conveyor Screws and Accessories



If desired, conveyor screws may be furnished in abrasion resistant metals, such as 40/50 carbon, T-I, nickel steel or may be coated with Stellite, Postalloy, Airco, etc.

When handling abrasive materials, consideration should be given to

protecting conveyor accessories. Hardened couplings, outboard bearings, trough ends and hangers with white iron or hardened surface bearings can be furnished. Troughs of heavy abrasion resistant metals are also available.

## Hammond Hard-Surfaced Conveyor Screws

Hammond Hard-Surfaced conveyor screws are designed to prolong the life of flights while handling abrasive materials. An alloy is permanently fused to the carrying side (of a width in relation to the cross-

sectional load, see chart) of the fighting face. As shown in the photo, the alloy is also applied along the ends of the fighting up to the pipe to reduce wear at the hanger joints where some material build-up generally occurs.

Conveyor Diameter	Width of Hard Surface	Applicable Conveyor Screw ▲
6	1 "	6H304, 6H308, 6H312 6S307, 6S309, 6S312
9	1½"	9H306, 9H312, 9H406, 9H412 9S307, 9S309, 9S312, 9S407, 9S409, 9S412
10	1½"	10H306, 10H412 10S309, 10S312, 10S412
12	2 "	12H408, 12H412, 12H508, 12H512 12S409, 12S412, 12S509, 12S512, 12S612
14	2 "	14H508 14S509, 14S512, 14S612
16	2½"	16H610 16S609, 16S612
18	2½"	18S612, 18S712
20	3 "	20S612, 20S712
24	3 "	24S712

▲ For Heavier Flight Thickness We Recommend An Overlay Process Such As Stellite, Postalloy or Airco.

## Corrosion Resistant Conveyor Screws

Conveyor screws which must handle corrosive materials may be made of special resistant metals such as stainless steel, Monel, Inconel, Cor-Ten, etc. In addition, they may be hot dip galvanized for protection against mild corrosion.

## Stainless Steel Conveyor Screws

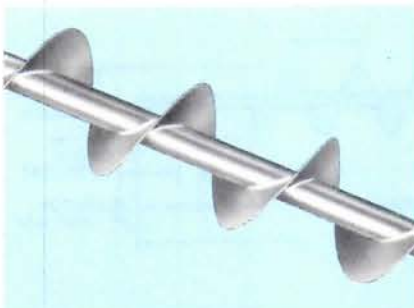

Stainless steel screw conveyors are ideal for use in the food, drug, chemical and virtually all other industries where either sanitation, corrosion or extreme temperatures are a problem. Stainless steel conveyor screws and parts are manufactured to the same specifications as are standard mild steel. The

flights can be welded continuously to one or both sides of the pipe and the weld may then be ground to your specifications. Any analysis of stainless steel may be used in the construction of your screw conveyor. Stainless accessories such as hangers, troughs, etc., are also available.





# Special Conveyor Screw Designs

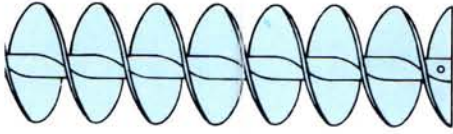

## Double Flight

A double flight conveyor screw incorporates two rows of flighting of the same hand wrapped around the conveyor pipe. It creates a more even discharge from the conveyor minimizing surges which is desirable when feeding into a scale hopper. Usually the double flight is required for only the last two or three pitches prior to a discharge to accomplish its purpose.

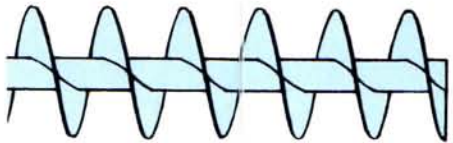

## Short Pitch

Short pitch, usually half pitch, but may be any pitch under standard full pitch, is often used for the full length of inclined conveyors to maintain efficient conveying action.

In horizontal conveyors as half pitch it is fitted under choke feed hoppers to create a lowering of cross section load beyond the feed area permitting the use of intermediate hanger bearings and extended conveyor lengths. A half pitch conveyor will have half the capacity of a full pitch conveyor under the same cross section load and speed.

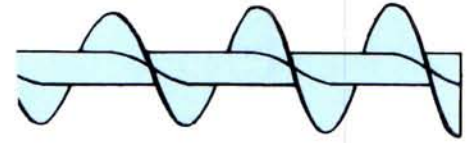
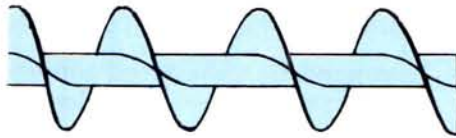

## Tapered Diameter

Tapered diameter conveyor screws also create a draw off of material for the length of the opening. This construction is often used in conjunction with half pitch to create greater flexibility in conveyor design. When using tapered diameter the trough should also be tapered to minimize the bed of material in the trough at the feed end.

## Variable Pitch

Variable pitch conveyor screws are used as feeder screws under a long storage hopper. They permit a draw off of material for the length of the opening. Otherwise material will flow from the extreme feed end of the opening only and if the hopper is never completely emptied material can stagnate.

Conveyor assemblies incorporating the modifications above are pictured on page 18 and 19.

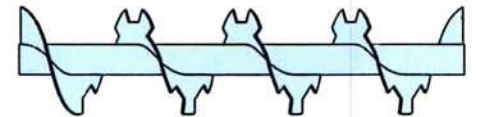

## Cut Flights

By cutting deep notches in the flight a very efficient mixing action of dry materials is created particularly at high speeds. The material is chopped and agitated as it is conveyed. This construction is also useful when conveying materials which tend to ball or lump.

Solid shaft is generally used only on short conveyors operating under extreme loads requiring extra torque capacity. The diagram shows the data required for ordering.

## Solid Shaft Conveyor Screw

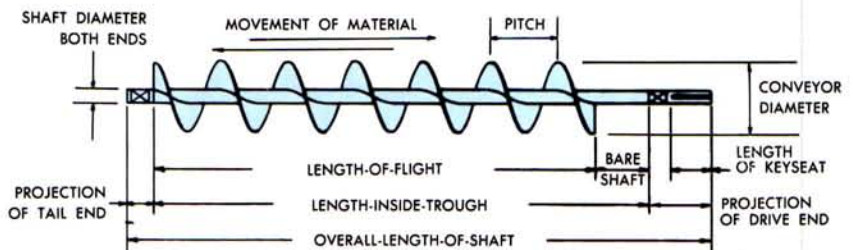





# Pipe Bushings and Lugs

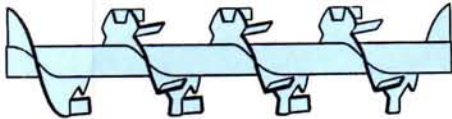

## Cut and Folded

This construction creates an even greater agitation than cut flights alone. It is also useful in cooling or drying light materials in conjunction with dome type covers.

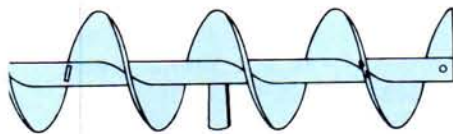

## Mixing Paddles

Any standard conveyor screw of either cut flight or cut and folded flight can be fitted with paddles for additional mixing action and to further retard the flow of material.

These paddles are usually welded in place at the hand opposite to the hand of the screw flighting. They can also be adjustable in hand and pitch.

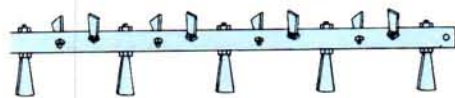

## Paddle Conveyor

For the greatest stirring action when conveying efficiency is not important, the flighting can be eliminated entirely resulting in a paddle conveyor as pictured.

The possible variations in conveyor screw, using the constructions described on the opposite page and above are almost limitless. If in question, consult our engineering department for specific recommendations.

PIPE BUSHINGS			
Standard Pipe Size	Shaft Diameter	Part Number	Weight Per 100
1¼	1	141-0224	70
2	1½	141-0331	220
2½	2	141-0448	240
3	2⅞	141-0554	410
3½	3	141-0661	430
4	3	141-0778	830
4	3⅞	141-0885	730

Internal collars are normally used in all types of conveyor screws to create a close fit to the end or coupling shafts. When purchased separately, they are not drilled for the coupling bolts since they and the pipe ends are drilled after assembly.



END LUGS						
Size of Conveyor	Nominal Pipe Size	Feed End		Discharge End		Weight Per 100
		Right Hand Part Number	Left Hand Part Number	Right Hand Part Number	Left Hand Part Number	
6"	2	145-0220	145-1434	145-0881	145-2093	6
9"	2-2½	145-0337	145-1541	145-0998	145-2200	16
10"	2-2½	145-0337	145-1541	145-0998	145-2200	16
12"	2½	145-0444	145-1657	145-1103	145-2317	35
12"	3	145-0444	145-1657	145-1103	145-2317	35
12"	3½	145-0444	145-1657	145-1103	145-2317	35
14"	3	145-0550	145-1764	145-1210	145-2424	53
14"	3½	145-0550	145-1764	145-1210	145-2424	53
16"	3½	145-0550	145-1764	145-1210	145-2424	53
18"	3½-4	145-0667	145-1871	145-0667	145-1871	150
20"	3½-4	145-0667	145-1871	145-0667	145-1871	150
24"	4	145-0667	145-1871	145-0667	145-1871	150

End lugs are made of heavy gauge steel and are designed to provide the greatest amount of support to the conveyor flighting with the least obstruction to the flow of material. When ordering, specify whether lugs are required for the Feed or the Discharge End and whether they are for a Right or Left Hand conveyor.



Formed Steel Lug for Feed End



Formed Steel Lug for Discharge End





# Bolts and Coupling Shafts

## Tem-U-Lac Coupling Bolts

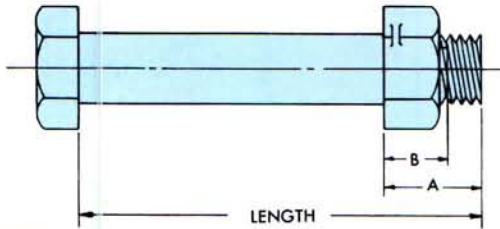

The Tem-U-Lac is a special bolt and nut forged of high analysis steel to give the required toughness for the severe service encountered. It has a hex head and the thread is cut to the proper length so that it does not project into and cut or wear the pipe walls. The self-locking hexagon nut features a stainless steel pin which follows the bolt thread while the nut is being tightened down. This prevents the nut from vibrating or working loose, causing damage and downtime, yet it loosens easily when pressure is applied by an ordinary wrench.

### DIMENSIONS IN INCHES AND AVERAGE WEIGHTS IN POUNDS

Shaft Diameter	Pipe Size	Bolt Size	Part Number	Weight Per 100	Dimensions	
					A	B
1"	1 1/4	3/8 x 2 1/8	155-6067	10	1/2	3/8
1 1/2"	2	1/2 x 3	155-6091	25	3/4	1/2
2"	2 1/2	5/8 x 3 5/8	155-6125	45	7/8	5/8
2 7/16"	3	5/8 x 4 3/8	155-6158	52	1	5/8
3"	3 1/2	3/4 x 5	155-6182	86	1 1/8	3/4
3"	4	3/4 x 5 1/2	155-6257	88	1 1/8	3/4
3 7/16"	4	7/8 x 5 1/2	155-6299	92	1 1/8	7/8

## Screw Conveyor Couplings

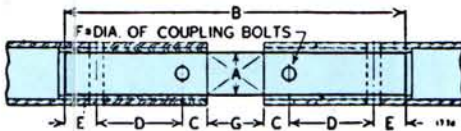

Made from selected cold rolled steel shafting, coupling shafts are jig-drilled to assure a match with the jig-drilled conveyor pipe. When handling non-abrasive materials, standard cold rolled steel couplings are recommended. Hardened steel couplings are recommended when handling abrasives and are case-hardened with a tough ductile core.

Shaft Size A	PART NUMBER		B	C	D	E	F	G	Wgt.
	Cold Rolled Steel Couplings	Hardened Steel Couplings							
1	147-0228	147-1101	7 1/2	1/2	2	1/2	3/8	1 1/2	1.5
1 1/2	147-0335	147-1218	11 1/2	7/8	3	7/8	1/2	2	5.6
2	147-0442	147-1325	11 1/2	7/8	3	7/8	5/8	2	9.6
2 7/16	147-0558	147-1432	12 3/4	1 5/16	3	1 5/16	5/8	3	16.2
3	147-0772	147-1549	13	1	3	1	3/4	3	24.7
3 7/16	147-0889	147-1655	17 1/2	1 1/2	4	1 1/4	7/8	4	44.5

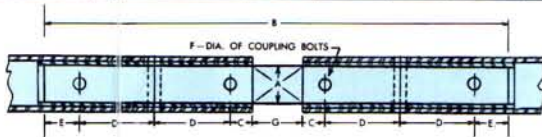

### High Torque Construction

The motor size limitations specified on page 10, can often be increased considerably through the use of three coupling bolts in the end of the conveyor pipe rather than the standard two bolts. The conveyor drive, tail and coupling shafts are jig-drilled to match the three holes in the conveyor pipe. Consult our engineering department for maximum drive sizes.

Shaft Size A	PART NUMBER		B	C	D	E	F	G	Wgt.
	Cold Rolled Steel Couplings	Hardened Steel Couplings							
1 1/2	147-0343	147-0350	17 1/2	7/8	3	7/8	1/2	2	8.5
2	147-0459	147-0467	17 1/2	7/8	3	7/8	5/8	2	14.5
2 7/16	147-0566	147-0574	18 3/4	1 5/16	3	1 5/16	5/8	3	23.8
3	147-0780	147-1556	19	1	3	1	3/4	3	36
3 7/16	147-0897	147-0905	25 1/2	1 1/2	4	1 1/4	7/8	4	65





# Drive and End Shafts

Shaft Diameter	DRIVE SHAFTS			
	Without End Seal		With End Seal	
	For #100, #101 Trough End	For #102, #103 Trough End	For #100, #101 Trough End	For #102, #103 Trough End
1	152-0352	152-0212	--	--
1½	152-0709	152-0568	152-0774	152-0709
2	152-1053	152-0915	152-1129	152-1053
2⅞	152-1475	152-1269	152-1541	152-1400
3	152-1897	152-1681	152-1962	152-1822
3⅞	152-2176	152-2036	152-2242	152-2101

END SHAFTS			
Without End Seal		With End Seal	
For #100, #101 Trough End	For #102, #103 Trough End	For #100, #101 Trough End	For #102, #103 Trough End
150-0354	150-0214	--	--
150-0701	150-0560	150-0842	150-0776
150-1196	150-1055	150-1337	150-1261
150-1758	150-1477	150-1824	150-1618
150-2178	150-1964	150-2244	150-2103
150-2459	150-2319	150-2525	150-2384

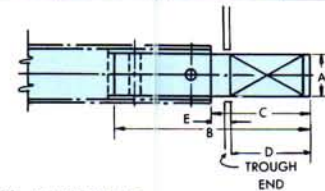
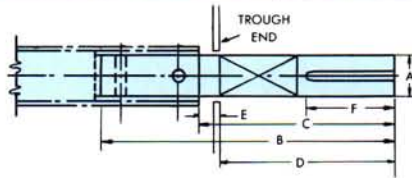

DIMENSIONS IN INCHES AND AVERAGE WEIGHTS IN POUNDS

Shaft Size "A"	DRIVE SHAFTS							
	Part Number	B	C	D	E	F	Key Seat	Wgt.
1"	152-0212	7⅞	4⅞	3⅞	1⅞	2¼	¼ x ⅞	1.8
1"	152-0352	8⅞	5⅞	4⅞	1⅞	2¼	¼ x ⅞	1.9
1½"	152-0568	11½	6¾	5½	1¼	3¼	⅜ x ¾	5.8
1½"	152-0709	13¼	8½	7¼	1¼	3¼	⅜ x ¾	6.7
1½"	152-0774	14¼	9½	8¼	1¼	3¼	⅜ x ¾	7.2
2"	152-0915	13⅞	8⅞	7⅞	1¼	4½	½ x ¼	11.7
2"	152-1053	14⅞	10⅞	8⅞	1¼	4½	½ x ¼	13.3
2"	152-1129	16½	11¾	10½	1¼	4½	½ x ¼	14.7
2⅞"	152-1269	15⅞	10¼	8⅞	1⅞	5½	⅝ x ⅝	20.0
2⅞"	152-1400	16⅞	12	10⅞	1⅞	5½	⅝ x ⅝	22.0
2⅞"	152-1475	17⅞	12½	10⅞	1⅞	5½	⅝ x ⅝	23.0
2⅞"	152-1541	19⅞	14¼	12⅞	1⅞	5½	⅝ x ⅝	25.4
3"	152-1681	16⅞	11⅞	9¾	1⅞	6	¾ x ¾	33.3
3"	152-1822	18⅞	13⅞	11½	1⅞	6	¾ x ¾	37.0
3"	152-1897	19⅞	14⅞	12¼	1⅞	6	¾ x ¾	38.3
3"	152-1962	20⅞	15⅞	14	1⅞	6	¾ x ¾	41.8
3⅞"	152-2036	20⅞	13⅞	11½	2⅞	7¼	⅞ x ⅞	60.0
3⅞"	152-2101	22⅞	16⅞	13¾	2⅞	7¼	⅞ x ⅞	66.0
3⅞"	152-2176	23⅞	16⅞	14½	2⅞	7¼	⅞ x ⅞	68.0
3⅞"	152-2242	25⅞	19⅞	16¾	2⅞	7¼	⅞ x ⅞	75.0

END SHAFTS					
Shaft Size "A"	Part Number	B	C	D	Wgt.
1"	150-0214	5⅞	2⅞	1⅞	1.2
1"	150-0354	6⅞	3⅞	2⅞	1.4
1½"	150-0560	8¼	3½	2¼	4.2
1½"	150-0701	9¼	4½	3¼	4.7
1½"	150-0776	10	5¼	4	5.0
1½"	150-0842	11	6¼	5	5.5
2"	150-1055	8⅞	3⅞	2⅞	7.6
2"	150-1196	10¼	5½	4¼	9.1
2"	150-1261	10⅞	5⅞	4⅞	9.2
2"	150-1337	12	7¼	6	10.7
2⅞"	150-1477	9⅞	4¾	2⅞	13.0
2⅞"	150-1618	11⅞	6½	4⅞	15.1
2⅞"	150-1758	11⅞	7	5⅞	15.8
2⅞"	150-1824	13⅞	8¾	6⅞	18.2
3"	150-1964	10⅞	5⅞	3¾	21.0
3"	150-2103	12⅞	7⅞	5½	24.5
3"	150-2178	13⅞	8⅞	6¼	26.0
3"	150-2244	14⅞	9⅞	8	29.0
3⅞"	150-2319	13⅞	6⅞	4¼	39.2
3⅞"	150-2384	15⅞	8⅞	6½	45.8
3⅞"	150-2459	16⅞	9⅞	7¼	48.0
3⅞"	150-2525	18⅞	11⅞	9½	54.0

All shafts normally drilled and keyseated. Keys are not included. If shafts are required with other than standard projection and keyway or with other special specifications details should accompany order.

The conveyor drive shaft transmits the rotary motion from the drive unit to the conveyor screw. They are, therefore, of high-quality, cold-rolled steel and are manufactured to closely controlled tolerances to fit the bearing clearances. Drive shaft keyways are accurately cut to transmission specifications and coupling bolt holes are jig-drilled to assure perfect alignment with the jig-drilled conveyor pipe.

End Shafts support the conveyor screw and are of selected steel and are manufactured to close tolerances for proper fit with the end bearing. End shafts are jig-drilled for perfect alignment.

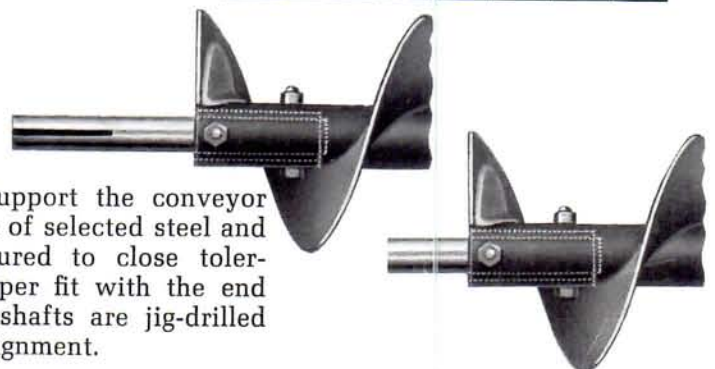





# Hangers

## DIMENSIONS FOR ALL HANGER STYLES

DIMENSIONS IN INCHES AND AVERAGE WEIGHTS IN POUNDS													
Diameter of Conveyor	Bearing Bore	Weight	▲Bearing Length	A	B	C	D	E	F	G	H	J	K
4	1	4	1½	5	7¾	6¾	3⅝	3	¼	2	⅜	¾	--
6	1½	6	2	7	9¾	8¾	4½	4	¼	2½	⅜	¾	6
9	1½	8	2	10	13½	12¼	6⅞	4	¼	2½	⅜	1	6
9	2	9	2	10	13½	12¼	6⅞	4	¼	2½	⅜	1	6
10	1½	9	2	11	14½	13¼	6⅞	4	¼	2½	⅜	1	6
10	2	10	2	11	14½	13¼	6⅞	4	¼	2½	⅜	1	6
12	2	14	2	13	17½	15¾	7¾	4	⅜	2½	½	1¼	6½
12	2⅞	20	3	13	17½	15¾	7¾	4	⅜	2½	½	1¼	6½
12	3	22	3	13	17½	15¾	7¾	4	⅜	2½	½	1¼	6½
14	2⅞	23	3	15	19½	17¾	9¼	4	½	2½	½	1⅜	6½
14	3	25	3	15	19½	17¾	9¼	4	½	2½	½	1⅜	6½
16	3	28	3	17	21½	19¾	10⅞	4	½	2½	½	1⅜	6½
18	3	29	3	19	24½	22¼	12⅞	5	½	3½	⅝	1⅝	6½
18	3⅞	31	4	19	24½	22¼	12⅞	5	½	3½	⅝	1⅝	7
20	3	32	3	21	26½	24¼	13½	5	½	3½	⅝	1⅝	6½
20	3⅞	34	4	21	26½	24¼	13½	5	½	3½	⅝	1⅝	7
24	3⅞	40	4	25	30½	28¼	16½	5	½	3½	⅝	1¾	7

Babbitt, bronze and ball bearing hangers come standard with lubrication pipe & grease fitting. Lube pipe & fitting also available with other bearings. Consult our sales office.

▲ Actual bearing length is ⅛ less than nominal dimension shown here.

These hangers are the most popular styles for the usual conveyor application as they offer the least possible obstruction to the flow of material. The Style 226 is the most popular since it mounts completely inside the trough and, therefore, is more suitable for use with dust-tight or weather-tight covers. Both hangers have wide top bars for greater stability and to permit their mounting across trough flange joints. The standard bearings used are Babbitt, Hard Iron, Arguto Wood, Bronze and Nylon or Nylatron; also available on special order is Bronze Oilite, Gatke, Stellite, Teflon or practically any conceivable bearing material.

Style No. 220

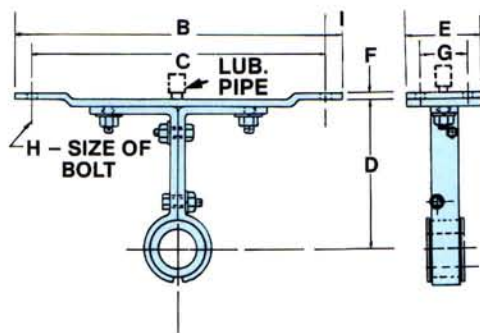

Style No. 226

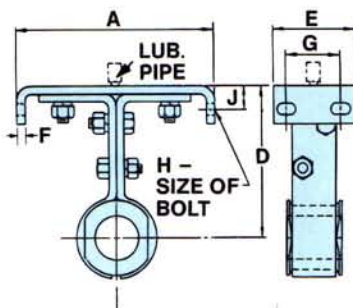





# Hangers

These are hangers designed for the most severe abrasive service. The Style 216 is the most popular since it will mount on the inside of the trough and therefore is most suitable for use with dust-tight or weather-tight covers. Both hangers have wide top bars for greater stability and to permit their mounting across trough flange joints. Because of the usual application of these hangers hard iron bearings are standard, however, Arguto Wood bearings are readily available.

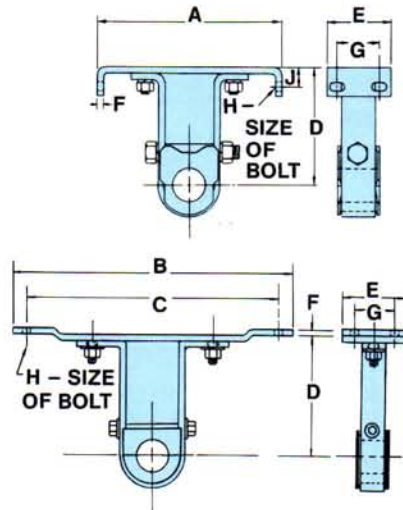

Style No. 230



Style No. 216

These hangers feature a self-aligning ball bearing. This results in lower power requirements and quieter operation. They are, therefore, particularly desirable for use in extremely long conveyors or conveyors operating at higher speeds. The Style 260 or 270 hangers are, however, not recommended for use in handling "dirty", gritty or abrasive materials. Alemite bearings are generally furnished although the bearings can also be considered as "Sealed for Life". The Style 270 hanger is the more popular as it mounts completely inside the trough and is, therefore, more suitable for use with dust-tight or weather-tight covers. Both hangers have wide top bars to permit their mounting across trough joints and to provide greater stability which is particularly important when using self-aligning bearings.

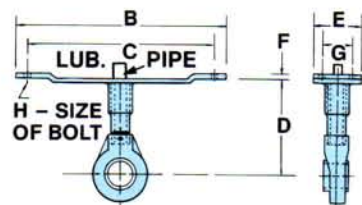

Style No. 260

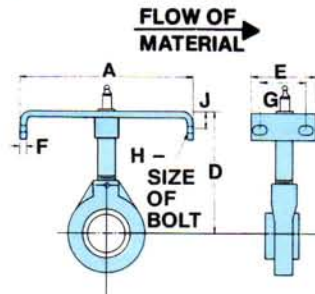

Style No. 270

Style No. 326 hanger is designed for use where hot materials are being conveyed and the length requires three or more sections of screw conveyor. The hanger top bar is free to slide on the angle guides to compensate for any unequal expansion between the trough and the screw conveyor. The 326 fits inside the trough beneath the cover and is suitable for use with a dust-tight or weather-proof cover. Its design offers a minimum of resistance to material flow and removable bearings made of special materials can be furnished to meet specific requirements. Hard-iron bearings, normally used with hardened steel conveyor couplings, are standard and will be furnished unless otherwise specified.

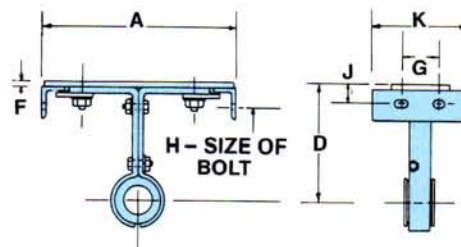

**Note:** Dimensional Data shown on page 36. Part Numbers shown on page 38.

Expansion  
Style No. 326





# Hangers

PART NUMBERS FOR ALL HANGER STYLES										
Diameter of Conveyor	Bearing Bore	WITH HARD IRON BEARING					WITH WOOD BEARING			
		Style 216 Part Number	Style 230 Part Number	Style 220 Part Number	Style 226 Part Number	Style 326 Part Number	Style 216 Part Number	Style 230 Part Number	Style 220 Part Number	Style 226 Part Number
4	1"	—	—	162-0145	163-0144	—	—	—	162-2612	163-2660
6	1 1/2"	160-0147	161-0146	162-0210	163-0219	164-0143	160-2523	161-1219	162-2661	163-2736
9	1 1/2"	160-0212	161-0211	162-0285	163-0284	164-0218	160-2598	161-1326	162-2737	163-2801
	2"	160-0287	161-0286	162-0350	163-0359	164-0283	160-2663	161-1391	162-2802	163-2876
10	1 1/2"	160-0352	161-0351	162-0426	163-0425	164-0358	160-2739	161-1482	162-2877	163-2942
	2"	160-0428	161-0427	162-0491	163-0490	164-0424	160-2804	161-1557	162-2943	163-3015
12	2"	160-0493	161-0492	162-0566	163-0565	164-0499	160-2879	161-1649	162-3016	163-3080
	2 7/16"	160-0568	161-0567	162-0632	163-0631	164-0564	160-2945	161-1706	162-3081	163-3155
	3"	160-0634	161-0633	162-0707	163-0706	164-0630	160-3018	161-1797	162-3156	163-3221
14	2 7/16"	160-0709	161-0708	162-0772	163-0771	164-0705	160-3083	161-1862	162-3222	163-3296
	3"	160-0774	161-0773	162-0848	163-0847	164-0770	160-3158	161-1938	162-3297	163-3361
16	3"	160-0840	161-0849	162-0913	163-0912	164-0846	160-3224	161-2019	162-3362	163-3437
18	3"	160-0915	161-0914	162-0988	163-0987	164-0911	160-3299	161-2167	162-3438	163-3502
	3 7/16"	160-0980	161-0989	162-1051	163-1050	164-0986	160-3364	161-2209	162-3503	163-3577
20	3"	160-1053	161-1052	162-1127	163-1126	164-1059	160-3430	161-2316	162-3578	163-3643
	3 7/16"	160-1129	161-1128	162-1192	163-1191	164-1125	160-3505	161-2423	162-3644	163-3718
24	3 7/16"	160-1194	161-1193	162-1267	163-1266	164-1190	160-3570	161-2506	162-3719	163-3783
	3 15/16"	160-1236	161-1177	162-1291	163-1357	164-1224				
30	4 7/16"	N/A	N/A	162-1309	163-1365	164-1232				

Diameter of Conveyor	Bearing Bore	WITH BABBITT BEARING		WITH BRONZE BEARING		WITH WHITE NYLON BEARING		WITH ANTI-FRICTION BEARING	
		Style 220 Part Number	Style 226 Part Number	Style 220 Part Number	Style 226 Part Number	Style 220 Part Number	Style 226 Part Number	Style 260 Part Number	Style 270 Part Number
4	1"	162-1408	163-1407	162-5045	163-5044	--	--	--	--
6	1 1/2"	162-1473	163-1472	162-5110	163-5119	162-3859	163-3924	166-0141	167-0140
9	1 1/2"	162-1549	163-1548	162-5185	163-5184	162-3925	163-3999	166-0216	167-0215
	2"	162-1614	163-1613	162-5250	163-5259	162-3990	163-4062	166-0281	167-0280
10	1 1/2"	162-1689	163-1688	162-5326	163-5325	162-4063	163-4138	166-0356	167-0355
	2"	162-1754	163-1753	162-5391	163-5390	162-4139	163-4203	166-0422	167-0421
12	2"	162-1820	163-1829	162-5466	163-5465	162-4204	163-4278	166-0497	167-0496
	2 7/16"	162-1895	163-1894	162-5532	163-5531	162-4279	163-4344	166-0562	167-0561
	3"	162-1960	163-1969	162-5607	163-5606	162-4345	163-4419	166-0638	167-0637
14	2 7/16"	162-2034	163-2033	162-5672	163-5671	162-4410	163-4484	166-0703	167-0702
	3"	162-2109	163-2108	162-5748	163-5747	162-4485	163-4559	166-0778	167-0777
16	3"	162-2174	163-2173	162-5813	163-5812	162-4550	163-4625	166-0844	167-0843
18	3"	162-2240	163-2249	162-5888	163-5887	162-4626	163-4690	166-0919	167-0918
	3 7/16"	162-2315	163-2314	162-5953	163-5952	162-4659	163-4732	166-0943	167-0942
20	3"	162-2380	163-2389	162-6027	163-6026	162-4691	163-4765	166-0984	167-0983
	3 7/16"	162-2455	163-2454	162-6092	163-6091	162-4741	163-4799	166-1008	167-1007
24	3 7/16"	162-2521	163-2520	162-6167	163-6166	162-4782	163-4815	166-1057	167-1056

Note: See pages 36 & 37 for dimensional data.



# Hangers



## Flared Trough Hanger

Hangers for use in flared troughs may be furnished in any of the fabricated hanger styles shown on pages 36 and 37. A Style 226 modified for a flared trough is pictured. Special hanger designs may be furnished to meet your requirements. Please refer to page 52 for additional information concerning flared troughs. Although normally supplied with babbitted, bronze or hard-iron bearings, Arguto, Micarta, Synthane, Nylon, Bronze Oilite or other types of bearings are available.

## Replacement Hanger Bearings



Bearing for  
Style 220, 226, 326 Hangers



Bearing for  
Style 216, 230 Hangers



Bearing for  
Style 260, 270 Hangers

When ordering bearings for screw conveyor hangers, specify the bore diameter, style of hanger and kind of bearing material.

### Enduro-Bearings™ and Enduro-Seals™

Highly efficient bearings and seals, providing long term solutions for operations in tough abrasive environments

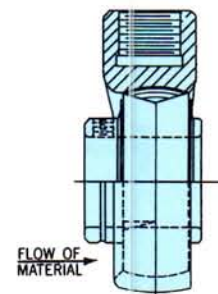
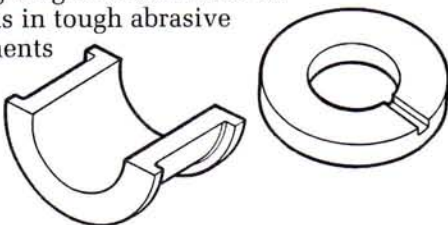

**Note:** Style 260 and 270 hangers and bearings should be mounted as shown by the "Flow of Material" arrow.





# Transmission Flange Bearings

Transmission Flange Bearings are of fabricated steel with the backing and end faces machine finished. Additional clearance is provided at the base of the bolt holes for ease of assembly. The bearings are accurately broached to "transmission" tolerances and the bore is concentric to the flange back. 1/8" Alemite fittings (No. 1610 hydraulic type) are furnished and the bearings are grooved to distribute the lubricant uniformly.

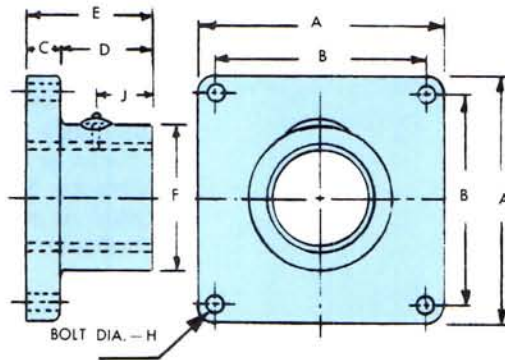

**DIMENSIONS IN INCHES AND AVERAGE WEIGHTS IN POUNDS**

*Shaft Size	Babbitt Bearing Part Number	Bronze Bearing Part Number	A	B	C	D	E	F	H	J	Weight
1"★	205-0284★	205-1126	4★	3 <sup>5</sup> / <sub>16</sub> ★	3 <sup>1</sup> / <sub>16</sub>	1 <sup>7</sup> / <sub>16</sub>	1 <sup>5</sup> / <sub>8</sub>	2	3 <sup>3</sup> / <sub>8</sub>	-	3.0
1 <sup>1</sup> / <sub>16</sub> "	205-0359	205-1191	5 <sup>1</sup> / <sub>8</sub>	4	5 <sup>1</sup> / <sub>16</sub>	2 <sup>1</sup> / <sub>16</sub>	3	2 <sup>3</sup> / <sub>8</sub>	7 <sup>1</sup> / <sub>16</sub>	1 <sup>1</sup> / <sub>16</sub>	6.5
1 <sup>1</sup> / <sub>2</sub> "	205-0425	205-1266	5 <sup>1</sup> / <sub>8</sub>	4	5 <sup>1</sup> / <sub>16</sub>	2 <sup>1</sup> / <sub>16</sub>	3	2 <sup>3</sup> / <sub>8</sub>	7 <sup>1</sup> / <sub>16</sub>	1 <sup>1</sup> / <sub>16</sub>	6.5
1 <sup>9</sup> / <sub>16</sub> "	205-0490	205-1332	6 <sup>3</sup> / <sub>8</sub>	5 <sup>1</sup> / <sub>8</sub>	3 <sup>3</sup> / <sub>8</sub>	3 <sup>3</sup> / <sub>8</sub>	4	2 <sup>7</sup> / <sub>8</sub>	9 <sup>1</sup> / <sub>16</sub>	1 <sup>7</sup> / <sub>8</sub>	13.0
2"	205-0565	205-1407	6 <sup>3</sup> / <sub>8</sub>	5 <sup>1</sup> / <sub>8</sub>	3 <sup>3</sup> / <sub>8</sub>	3 <sup>5</sup> / <sub>8</sub>	4	2 <sup>7</sup> / <sub>8</sub>	9 <sup>1</sup> / <sub>16</sub>	1 <sup>7</sup> / <sub>8</sub>	13.0
2 <sup>1</sup> / <sub>16</sub> "	205-0631	205-1472	6 <sup>7</sup> / <sub>8</sub>	5 <sup>5</sup> / <sub>8</sub>	3 <sup>3</sup> / <sub>8</sub>	4 <sup>5</sup> / <sub>8</sub>	5	3 <sup>1</sup> / <sub>2</sub>	9 <sup>1</sup> / <sub>16</sub>	2 <sup>3</sup> / <sub>8</sub>	20.0
2 <sup>1</sup> / <sub>16</sub> "	205-0706	205-1548	7 <sup>3</sup> / <sub>4</sub>	6	1 <sup>1</sup> / <sub>2</sub>	5	5 <sup>1</sup> / <sub>2</sub>	4	3 <sup>3</sup> / <sub>4</sub>	2 <sup>3</sup> / <sub>4</sub>	28.0
2 <sup>5</sup> / <sub>16</sub> "	205-0771	205-1613	7 <sup>3</sup> / <sub>4</sub>	6	1 <sup>1</sup> / <sub>2</sub>	5 <sup>1</sup> / <sub>2</sub>	6	4	3 <sup>3</sup> / <sub>4</sub>	3	32.0
3"	205-0847	205-1688	7 <sup>3</sup> / <sub>4</sub>	6	1 <sup>1</sup> / <sub>2</sub>	5 <sup>1</sup> / <sub>2</sub>	6	4	3 <sup>3</sup> / <sub>4</sub>	3	32.0
3 <sup>1</sup> / <sub>16</sub> "	205-0912	205-1753	8 <sup>7</sup> / <sub>16</sub>	6 <sup>3</sup> / <sub>4</sub>	1 <sup>1</sup> / <sub>2</sub>	6	6 <sup>1</sup> / <sub>2</sub>	4 <sup>1</sup> / <sub>2</sub>	3 <sup>3</sup> / <sub>4</sub>	3 <sup>7</sup> / <sub>16</sub>	39.0

\*Bores not listed — on application.  
 ★1" Size available with 2-hole oil impregnated wood bearing only.

**FASTER ACTION WITH FAX**

**TO SERVE YOU BETTER**

**219-931-0209**





# Trough Ends

Styles No. 100 and 101

DIMENSIONS IN INCHES AND AVERAGE WEIGHTS IN POUNDS																				
Diameter of Conveyor	Bearing Bore	Style 100		Style 101		A	B		C	D	E	F	G	H	J	K	L	M ★	N	Style 101 Weight with Bearing
		With Bearing Part Number	Without Bearing Part Number	With Bearing Part Number	Without Bearing Part Number		Without Seal xx	With Seal xx												
4	1	210-1400	264-1405	210-0147	264-0142	8	1 13/16	-	1 7/16	3 5/8	4 5/8	1	1 5/8	3/8	5 3/4	3/16	3 5/16	1 1/8	7/16	8
6	1 1/2	210-1475	264-1470	210-0212	264-0217	9 3/4	3 3/16	4 15/16	1 1/2	4 1/2	5 5/8	1	1 3/4	3/8	8 1/8	3/16	4	1 1/4	7/16	13
9	1 1/2	210-1541	264-1546	210-0287	264-0282	13 1/2	3 1/4	5	1 5/8	6 1/8	7 7/8	1 1/2	2 5/8	1/2	9 3/8	1/4	4	1 1/4	7/16	23
9	2	210-1616	264-1611	210-0352	264-0357	13 1/2	4 1/4	6	1 5/8	6 1/8	7 7/8	1 1/2	2 5/8	1/2	9 3/8	1/4	5 1/8	1 5/8	9/16	29
10	1 1/2	210-1681	264-1686	210-0428	264-0423	14 1/2	3 1/4	5	1 3/4	6 3/8	8 7/8	1 3/4	2 7/8	1/2	9 1/2	1/4	4	1 1/4	7/16	26
10	2	210-1756	264-1827	210-0493	264-0498	14 1/2	4 1/4	6	1 3/4	6 3/8	8 7/8	1 3/4	2 7/8	1/2	9 1/2	1/4	5 1/8	1 5/8	9/16	32
12	2	210-1822	264-1892	210-0568	264-0563	17 1/4	4 1/4	6	2	7 3/4	9 5/8	1 5/8	2 3/4	5/8	12 1/4	1/4	5 1/8	1 5/8	9/16	39
12	2 7/16	210-1897	264-1967	210-0634	264-0639	17 1/4	5 1/4	7	2	7 3/4	9 5/8	1 5/8	2 3/4	5/8	12 1/4	1/4	5 1/8	1 5/8	9/16	50
12	3	210-1962	264-2106	210-0709	264-0704	17 1/4	6 1/4	8	2	7 3/4	9 5/8	1 5/8	2 3/4	5/8	12 1/4	1/4	6	2	3/4	64
14	2 7/16	210-2036	264-2171	210-0774	264-0779	19 3/4	5 5/16	7 1/16	2	9 1/4	10 7/8	1 5/8	2 7/8	5/8	13 1/2	5/16	5 5/8	1 5/8	9/16	65
14	3	210-2101	264-2312	210-0840	264-0845	19 3/4	6 5/16	8 1/16	2	9 1/4	10 7/8	1 5/8	2 7/8	5/8	13 1/2	5/16	6	2	3/4	79
16	3	210-2176	264-2387	210-0915	264-0910	21 1/4	6 5/16	8 1/16	2 1/2	10 5/8	12	2	3 1/4	5/8	14 7/8	5/16	6	2	3/4	90
18	3	210-2242	264-2452	210-0980	264-0985	24 1/4	6 3/8	8 3/8	2 1/2	12 1/8	13 3/8	2	3 1/4	5/8	16	3/8	6	2	3/4	117
18	3 7/16	210-2317	264-2528	210-1053	264-1058	24 1/4	7 3/8	9 5/8	2 1/2	12 1/8	13 3/8	2	3 1/4	5/8	16	3/8	6 1/4	2	3/4	135
20	3	210-2382	264-2593	210-1129	264-1124	26 1/4	6 3/8	8 1/8	2 1/2	13 1/2	15	2 1/4	3 3/4	3/4	19 1/4	3/8	6	2	3/4	133
20	3 7/16	210-2457	264-2668	210-1194	264-1199	26 1/4	7 3/8	9 5/8	2 1/2	13 1/2	15	2 1/4	3 3/4	3/4	19 1/4	3/8	6 1/4	2	3/4	150
24	3 7/16	210-2523	264-2734	210-1269	264-1264	30 1/4	7 3/8	9 5/8	2 1/2	16 1/2	18 1/8	2 1/2	4 1/8	3/4	20	3/8	6 1/4	2	3/4	187

● Babbitt bearings are standard and furnished unless otherwise specified, except 4" size is supplied with two bolt oil impregnated selfaligning bearing only.

▲ Standard bolt hole centers will be furnished unless otherwise specified.

★ Length for trough end without seals will be furnished unless otherwise specified.

Bearings are furnished with 1/8" (no. 1610 Hydraulic type) Alemite Fitting.

xx Standard seal is packing seal housing as shown on page 45.

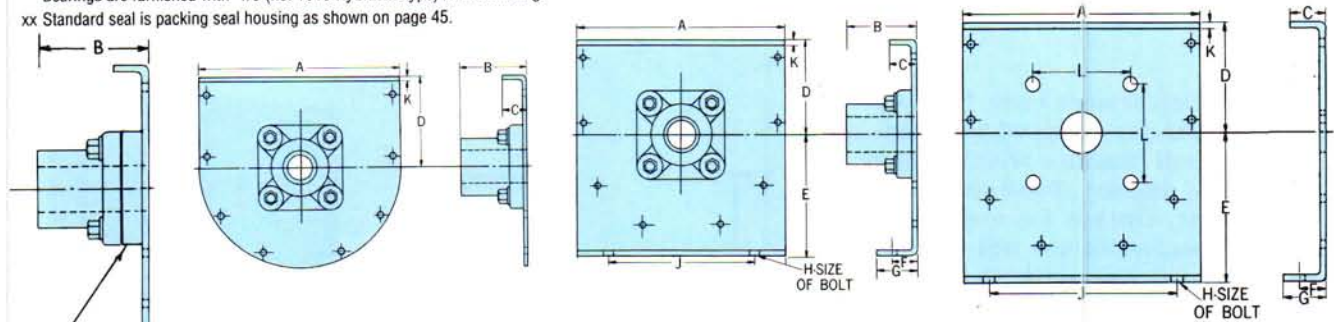

Style No. 100

Style No. 101



These are steel plate trough ends generally fitted with Babbitted Transmission Flange Bearings, although any bearing material may be used such as Bronze, Bronze Oil-ite, Arguto Wood, Nylon, etc. (for antifriction ball bearing trough ends, see page 42). Replacement Babbitt Bearings are pictured on page 40. In each type the top flange supports the cover of the conveyor. The bottom flange of the Style 101 is for support of the conveyor. When using the style 100 the conveyor must be supported either from above or from a foot on the trough end flange.





# Trough Ends

Styles No. 102 and 103

DIMENSIONS IN INCHES AND AVERAGE WEIGHTS IN POUNDS								
Diameter of Conveyor	Bearing Bore	WITHOUT FEET		WITH FEET		DIMENSIONS		
		●Part †Number	●Weight	●Part †Number	●Weight	B	C	D
4	1	212-2034	6	212-0772	7	1 <sup>5</sup> / <sub>8</sub>	3 <sup>1</sup> / <sub>16</sub>	3 <sup>3</sup> / <sub>8</sub>
6	1 <sup>1</sup> / <sub>2</sub>	212-2109	10	212-0848	12	2 <sup>1</sup> / <sub>4</sub>	3 <sup>1</sup> / <sub>16</sub>	4
9	1 <sup>1</sup> / <sub>2</sub>	212-2174	18	212-0913	23	2 <sup>5</sup> / <sub>16</sub>	1 <sup>1</sup> / <sub>4</sub>	4 <sup>1</sup> / <sub>16</sub>
9	2	212-2240	20	212-0988	25	2 <sup>9</sup> / <sub>16</sub>	1 <sup>1</sup> / <sub>4</sub>	4 <sup>5</sup> / <sub>16</sub>
10	1 <sup>1</sup> / <sub>2</sub>	212-2315	20	212-1051	26	2 <sup>5</sup> / <sub>16</sub>	1 <sup>1</sup> / <sub>4</sub>	4 <sup>1</sup> / <sub>16</sub>
10	2	212-2380	22	212-1127	28	2 <sup>9</sup> / <sub>16</sub>	1 <sup>1</sup> / <sub>4</sub>	4 <sup>5</sup> / <sub>16</sub>
12	2	212-2455	27	212-1192	34	2 <sup>9</sup> / <sub>16</sub>	1 <sup>1</sup> / <sub>4</sub>	4 <sup>5</sup> / <sub>16</sub>
12	2 <sup>7</sup> / <sub>16</sub>	212-2521	32	212-1267	39	2 <sup>15</sup> / <sub>16</sub>	1 <sup>1</sup> / <sub>4</sub>	4 <sup>11</sup> / <sub>16</sub>
12	3	212-2596	41	212-1333	48	3 <sup>3</sup> / <sub>4</sub>	1 <sup>1</sup> / <sub>4</sub>	5 <sup>1</sup> / <sub>2</sub>
14	2 <sup>7</sup> / <sub>16</sub>	212-2661	44	212-1408	54	3	5 <sup>1</sup> / <sub>16</sub>	4 <sup>3</sup> / <sub>4</sub>
14	3	212-2737	53	212-1473	63	3 <sup>13</sup> / <sub>16</sub>	5 <sup>1</sup> / <sub>16</sub>	5 <sup>9</sup> / <sub>16</sub>
16	3	212-2802	61	212-1549	74	3 <sup>13</sup> / <sub>16</sub>	5 <sup>1</sup> / <sub>16</sub>	5 <sup>9</sup> / <sub>16</sub>
18	3	212-2877	85	212-1614	100	3 <sup>7</sup> / <sub>8</sub>	3 <sup>3</sup> / <sub>8</sub>	5 <sup>5</sup> / <sub>8</sub>
18	3 <sup>7</sup> / <sub>16</sub>	212-2943	92	212-1689	107	4 <sup>3</sup> / <sub>8</sub>	3 <sup>3</sup> / <sub>8</sub>	6 <sup>5</sup> / <sub>8</sub>
20	3	212-3016	97	212-1754	117	3 <sup>7</sup> / <sub>8</sub>	3 <sup>3</sup> / <sub>8</sub>	5 <sup>5</sup> / <sub>8</sub>
20	3 <sup>7</sup> / <sub>16</sub>	212-3081	104	212-1820	124	4 <sup>3</sup> / <sub>8</sub>	3 <sup>3</sup> / <sub>8</sub>	6 <sup>5</sup> / <sub>8</sub>
24	3 <sup>7</sup> / <sub>16</sub>	212-3156	127	212-1895	160	4 <sup>3</sup> / <sub>8</sub>	3 <sup>3</sup> / <sub>8</sub>	6 <sup>5</sup> / <sub>8</sub>

† Flange bearings are furnished with 1/8" (No. 1610 Hydraulic type) Alemite Fittings.

● Part numbers and weights do not include seal.  
Standard seal is packing seal shown on page 45.

Anti-friction trough ends No. 102 and No. 103 are equipped with self-aligning ball bearings which allow for several degrees of end shaft misalignment. Unless for very light duty, these units are not recommended for use with the drive shaft. Chevron end thrusts or another type of rigid bearing support is normally recommended for use with the drive shaft. Refer to page 41 for dimensional data on these style trough ends.

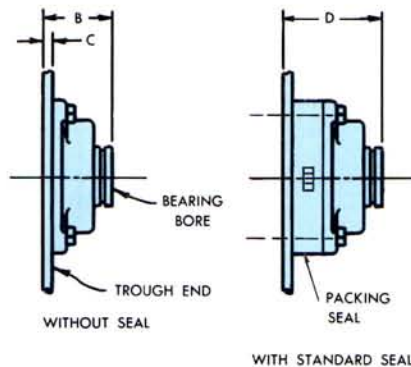

Anti-Friction Style No. 102 pictured without seal



Anti-Friction Style No. 103 pictured with packing seal







# Trough Ends

Styles No. 104, 107, 114 and 115

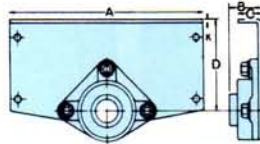

## DIMENSIONS IN INCHES AND AVERAGE WEIGHTS IN POUNDS

Diameter of Conveyor	Bearing Bore	Style 104 †Part Number	Style 107 †Part Number	A	B		C	D	K	Wgt. Style 104
					Style 104	Style 107				
6	1½	220-0145	220-1408	9¾	2¼	3¾	1½	4½	¾	9
9	1½	220-0210	220-1473	13½	2⅞	3¼	1⅝	6⅞	¼	14
9	2	220-0285	220-1549	13½	2⅞	4¼	1⅝	6⅞	¼	16
10	1½	220-0350	220-1614	14½	2⅞	3¼	1¾	6⅞	¼	15
10	2	220-0426	220-1689	14½	2⅞	4¼	1¾	6⅞	¼	17
12	2	220-0491	220-1754	17¼	2⅞	4¼	2	7¾	¼	22
12	2⅞	220-0566	220-1820	17¼	2⅞	5¼	2	7¾	¼	27
12	3	220-0632	220-1895	17¼	3¾	6¼	2	7¾	¼	36
14	2⅞	220-0707	220-1960	19¼	3	5⅞	2	9¼	⅝	32
14	3	220-0772	220-2034	19¼	3⅞	6⅞	2	9¼	⅝	41
16	3	220-0848	220-2109	21¼	3⅞	6⅞	2½	10⅞	⅝	50
18	3	220-0913	220-2174	24¼	3⅞	6⅞	2½	12⅞	⅝	57
18	3⅞	220-0988	220-2240	24¼	4⅞	7⅞	2½	12⅞	⅝	66
20	3	220-1051	220-2315	26¼	3⅞	6⅞	2½	13½	⅝	63
20	3⅞	220-1127	220-2380	26¼	4⅞	7⅞	2½	13½	⅝	70
24	3⅞	220-1192	220-2455	30¼	4⅞	7⅞	2½	16½	⅝	100

† Flange bearings are furnished with ¼" (No. 1610 Hydraulic type) Alemite Fittings.

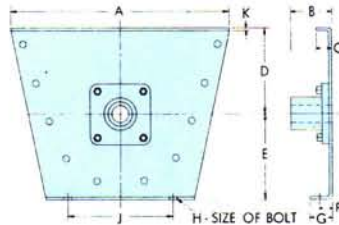

## Flared Trough End

Style No. 114 and Style No. 115

Flared Trough Ends are formed with a top flange to support the cover and a bottom flange which serves as feet. Its design fits the contour of the Flared Trough (see page 52). A Flared Trough End can be fitted with a babbitted transmission flange bearing (Style No. 114) or an anti-friction self-aligning ball bearing (as shown above, Style No. 115). Flange bearings of Bronze, Arguto Wood, Nylon, Bronze Oilite, etc., are also available. The end plate could also be fitted with a Chevron or Hammond end thrust.

Diameter of Conveyor	Bearing Bore	Babbitt Bearing Part Number	Ball Bearing* Part Number	A	B		B	C	D	E	F	G	H	J	K	Wgt.
					Style 114	Style 115										
6	1½	230-1190	230-0143	16⅝	3⅞	2¼	2⅞	1½	7	5⅞	1	1¾	¾	8⅞	¾	30
9	1½	230-1265	230-0218	21¼	3¼	2⅞	3¼	1⅝	9	7⅞	1½	2⅞	½	9⅞	¼	41
9	2	230-1331	230-0283	21¼	4¼	2⅞	4¼	1⅝	9	7⅞	1½	2⅞	½	9⅞	¼	55
12	2	230-1406	230-0358	26⅞	4⅞	2⅞	4⅞	2	10	9⅞	1⅝	2¾	⅝	12¼	⅝	75
12	2⅞	230-1471	230-0424	26⅞	5⅞	3	5⅞	2	10	9⅞	1⅝	2¾	⅝	12¼	⅝	86
12	3	230-1547	230-0499	26⅞	6⅞	3⅞	6⅞	2	10	9⅞	1⅝	2¾	⅝	12¼	⅝	100
14	2⅞	230-1612	230-0564	28⅞	5⅞	3	5⅞	2	11	10⅞	1⅝	2⅞	⅝	13½	⅝	96
14	3	230-1687	230-0630	28⅞	6⅞	3⅞	5⅞	2	11	10⅞	1⅝	2⅞	⅝	13½	⅝	110
16	3	230-1752	230-0705	32½	6⅞	3⅞	6⅞	2½	11½	12	2	3¼	⅝	14⅞	⅝	146
18	3	230-1828	230-0770	36½	6⅞	3⅞	6⅞	2½	12⅞	13⅞	2	3¼	⅝	16	⅝	167
18	3⅞	230-1893	230-0846	36½	7⅞	4⅞	7⅞	2½	12⅞	13⅞	2	3¼	⅝	16	⅝	185
20	3	230-1968	230-0911	39½	6⅞	3⅞	6⅞	2½	13½	15	2¼	3¾	¾	19¼	⅝	179
20	3⅞	230-2032	230-0986	39½	7⅞	4⅞	7⅞	2½	13½	15	2¼	3¾	¾	19¼	⅝	197
24	3⅞	230-2107	230-1059	45½	7⅞	4¼	7⅞	2½	16½	18⅞	2½	4⅞	¾	20	½	292

\* Transmission quality babbitt of our own specification is used and provides a bearing that has the ability go give excellent service with minimum up-keep. The bearings are accurately broached to "transmission" tolerances and the bore is concentric to the flange back. The babbitt is grooved to distribute the lubricant uniformly.

† Flange bearings are furnished with ¼" (No. 1610 Hydraulic type) Alemite fittings.





# Bolt On Shelf Trough Ends

**DIMENSIONS IN INCHES AND AVERAGE WEIGHTS IN POUNDS**

Shaft Size	Part Number*	A	B	C	D	E	F	Wgt.
1 1/2	260-1607	8	3/16	3	4 1/2	7 1/2	9 3/16	9
2	260-1615	8	3/16	3 1/2	4 3/4	8 1/4	9 11/16	11
2 7/16	260-1623	8 1/4	1/4	4	5 1/4	9 1/4	9 3/4	17
3	260-1631	8 1/2	1/4	4 1/2	6 1/4	10 3/4	10 1/4	21
3 3/16	260-1649	8 3/4	1/4	5 1/2	6 3/4	12 1/4	10 3/4	26
3 15/16	260-1656	9 1/2	3/8	5 1/2	7 1/2	13	11 7/8	45
4 1/16	260-1664	10	3/8	6	8 1/2	14 1/2	12 5/8	54
4 15/16	260-1672	10 1/4	3/8	7	9 1/4	16 1/4	12 7/8	65

**BOLT ON PUMP SEALS**

Shaft Size	Part Number*
1 1/2	271-1406
2	271-1414
2 7/16	271-1422
3	271-1430
3 3/16	271-1448
3 15/16	271-1455
4 1/16	271-1463
4 15/16	271-1471

\*Part No. Does Not Include Trough End, Bearing, or Seal.

Screw Conveyor Corporation has developed a universal bolt-on shelf and bolt-on pump type seal to be adaptable to existing trough ends. This provides a cost effective alternative for inventory stocking purchases.

The bolt-on shelf allows for the out-board mounting of the bearing making maintenance easy. The shelf not only offers a solid mount for the bearing but provides stability for drives including chain, v-belt, direct connect or use of a shaft mounted reducer. The drive shaft between the bearing and seal is exposed, so the bearing runs cooler.

The bolt-on pump type seal is available in eight standard bore sizes and is also field adaptable on existing trough ends. In order to maintain maximum flexibility, this shelf and trough end arrangement will also accept the traditional split end seal and waste pack seal.

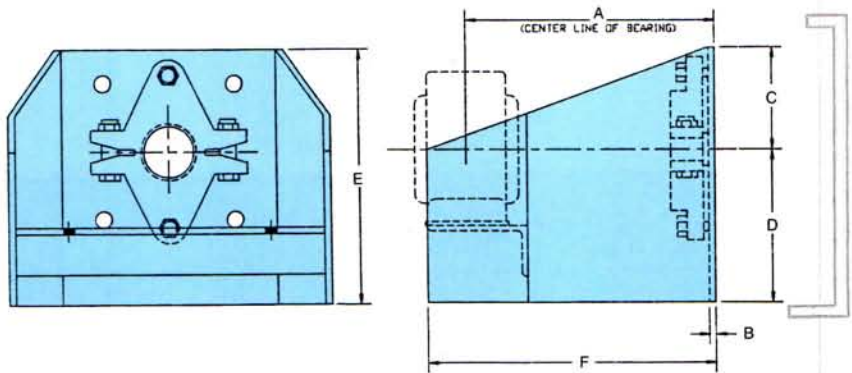

## Enduro-Change™ Split Flight Coupling

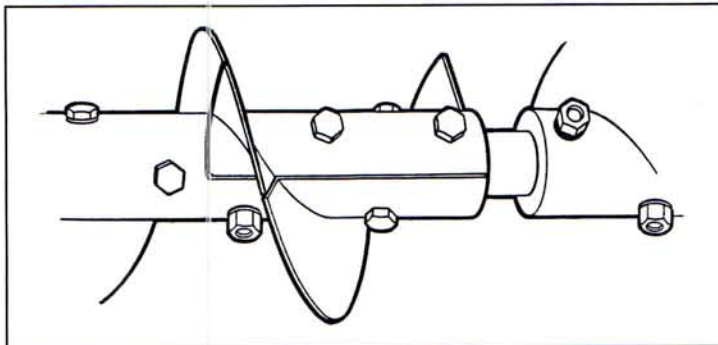

The Enduro-Change™ Split Flight Coupling is an improved version of quick interchange screw sections. It is designed for heavy-duty applications and allows truer alignment. When changing sections the hanger is not disturbed. All bolts are grade 8 with 1144 shafting. The quick disconnect feature is available in either Redi-Change keys (see page 30) or Enduro-Change Split Flight Coupling bushing construction.





# Trough End Dust Seals

## WPS Packing Seals

DIMENSIONS IN INCHES AND AVERAGE WEIGHTS IN POUNDS							
Shaft Size A	Part Number	Weight	B	C	D	E	WPS PACKING SEAL WITH LIP
							Part Number
1½	270-0144	5.2	1¾	5⅞	4 to 4⅝	7/16 to 9/16	270-0151
2	270-0219	6.7	1¾	6⅜	4⅜ to 5⅝	7/16 to 9/16	270-0227
27/16	270-0284	8.0	1¾	7⅞	5⅞ to 6⅞	7/16 to 5/8	270-0292
3	270-0359	12.0	1¾	7⅞	6 to 6⅞	¾	270-0367
37/16	270-0425	17.0	2¼	9¼	6¾ to 7¾	¾	270-0433

The Packing Seal housing is designed to protect the trough end bearings from material leakage and to protect the material being conveyed from the bearing lubricant. They can be provided with either lip-type or waste pack seals or combination of both. Waste packing is our standard and will be supplied unless otherwise specified.

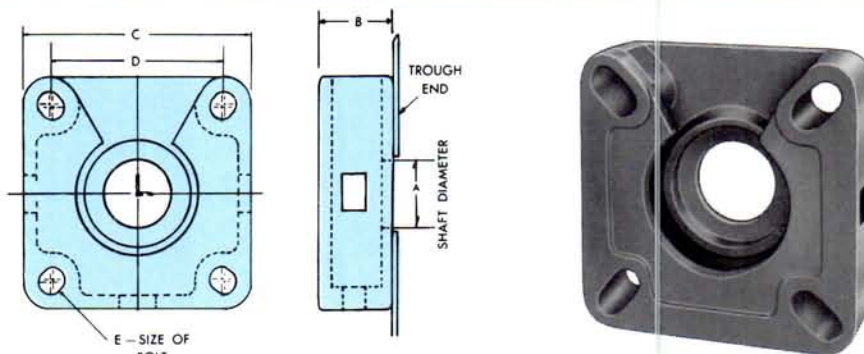

## Split Seal Glands

Shaft Size A	Part Number	B	C	D	E	F	Weight
1½	271-0218	3⅞	4½	5/8	1¼	½	4
2	271-0283	4⅞	5¼	5/8	1¼	½	5
27/16	271-0358	5	6¼	5/8	1¼	5/8	6
3	271-0424	5¾	7¼	5/8	1¼	5/8	8
37/16	271-0564	6⅞	8¼	7/8	1¾	¾	10

Split seal glands utilize twisted packing to prevent leakage of material being conveyed and to protect the material from bearing lubricant, moisture or dirt contamination. Generally used on shelf type trough ends, the seal glands are split to facilitate assembly and repacking.

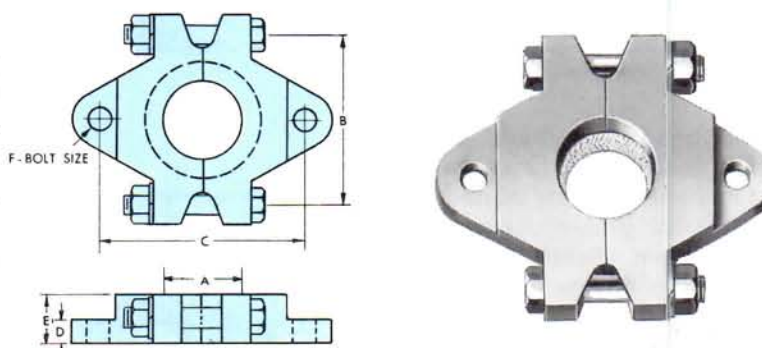

## Pump Type Seals

The pump seal is intended for the most severe service, particularly when a positive or negative pressure must be maintained. It may also be fitted with lantern rings and air or gas purge fittings. It can be used only with an outboard shelf type trough end.







# Chevron® Roller Bearing End Thrust with Trough End

Styles No. 109 and 110

DIMENSIONS IN INCHES AND AVERAGE WEIGHTS IN POUNDS									
Diameter of Conveyor	Shaft Size A	Dimension		STYLE No. 109 OUTSIDE PATTERN FOR STEEL TROUGH Without Feet			STYLE No. 110 OUTSIDE PATTERN FOR STEEL TROUGH With Feet		
		C	K	Part Number With Drive Shaft	Part Number With End Shaft	Weight With Drive Shaft	Part Number With Drive Shaft	Part Number With End Shaft	Weight With Drive Shaft
6	1½	1⅛	¾	242-0149	242-1337	26	240-0141	240-1339	30
9	1½	1	¼	242-0214	242-1402	35	240-0216	240-1404	40
9	2	1	¼	242-0289	242-1477	45	240-0281	240-1479	50
10	1½	1	¼	242-0354	242-1543	37	240-0356	240-1545	43
10	2	1	¼	242-0420	242-1618	47	240-0422	240-1610	53
12	2	1	¼	242-0495	242-1683	52	240-0497	240-1685	60
12	2⅞	1⅞	¼	242-0560	242-1758	71	240-0562	240-1750	79
12	3	1⅝	¼	242-0636	242-1824	97	240-0638	240-1826	105
14	2⅞	1½	⅜	242-0701	242-1899	83	240-0703	240-1891	94
14	3	1⅞	⅜	242-0776	242-1964	109	240-0778	240-1966	120
16	3	1⅞	⅜	242-0842	242-2038	124	240-0844	240-2030	131
18	3	1½	⅜	242-0917	242-2103	133	240-0919	240-2105	158
18	3⅞	2	⅜	242-0982	242-2178	180	240-0984	240-2170	205
20	3	1½	⅜	242-1055	242-2244	161	240-1057	240-2246	174
20	3⅞	2	⅜	242-1121	242-2319	208	240-1123	240-2311	221
24	3⅞	2	⅜	242-1196	242-2384	240	240-1198	240-2386	257

Shaft Size A	B	D	E	F	G	H	J	STANDARD KEYSEAT		
								Width	Depth	Length
1½	5	3	⅞	⅞	5¼	6	½	⅜	⅜	4¾
2	5	3	⅞	⅞	5⅝	6	⅝	½	¼	4¾
2⅞	5	3	1⅞	1⅞	5⅞	6⅞	⅝	⅜	⅜	4¾
3	6	3	1	1	6⅞	6⅞	¾	¾	⅜	5¼
3⅞	7	4	1¼	1½	7½	9⅞	⅞	⅞	⅞	6⅞

General dimensions of the trough end are shown on page 41.

Designed to handle medium to heavy thrust loads, the Chevron End Thrust has adequate radial and thrust capacity for practically any application and can absorb thrust in either direction. When starting a Screw Conveyor, thrust is created in the direction opposite to the flow of material. If this thrust is not contained, the hanger bearings, trough end and screw will wear at an increased rate. The Chevron can be furnished with either a drive or end shaft and it is recommended that the Screw Conveyor be driven through this type of thrust unit rather than a ball bearing (self-aligning) type. See page 41 for trough end dimensional data.

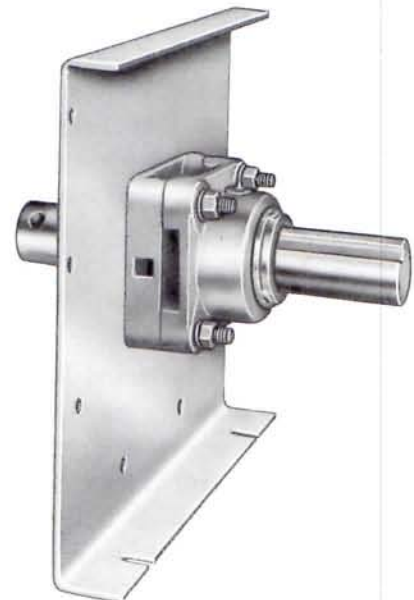
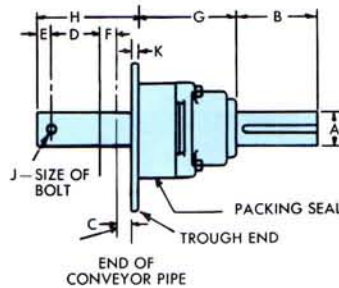

Style No. 110 shown. Style No. 109 is identical except without supporting feet.





# Hammond® Roller Bearing End Thrust with Trough End

DIMENSIONS IN INCHES AND AVERAGE WEIGHTS IN POUNDS														
Diameter of Shaft A	WITH DRIVE END SHAFT			WITH END SHAFT		B	C	D	E	F	G	H	J	K
	Std. Proj.	*Part Number	Weight ▲	*Part Number	Weight ▲									
1½	4	255-0143	60	255-0465	52	7¼	5¾	1¼	¾	6¾	1⅜	17/16	47/8	17/16
2	4½	255-0218	65	255-0499	56	7¼	5¾	1¼	¾	6¾	1⅜	115/16	47/8	17/8
27/16	5½	255-0283	80	255-0564	66	8	6¼	1¼	7/8	6¼	1⅜	27/16	55/8	115/16
3	6	255-0358	145	255-0630	119	10	8	1¾	1	8¼	1½	215/16	61/8	25/16
37/16	7	255-0424	170	255-0705	140	10	8	1¾	1	8¼	1½	37/16	61/8	25/8

\* Includes Roller Bearing End Thrust with keyseated drive shaft or standard end shaft and 1/8" Alemite Fitting, No. 1610 Hydraulic type.

▲ Weight does not include trough end. See page 41 for trough end only specifications.

This dual tapered roller bearing end thrust is designed for extra-heavy radial and thrust loads in either direction. Although the Hammond Roller Bearing Thrust Bearing is normally mounted on a steel plate trough end, the trough end is not furnished unless specified on the order. See pages 41-43 for trough end style and dimension data.

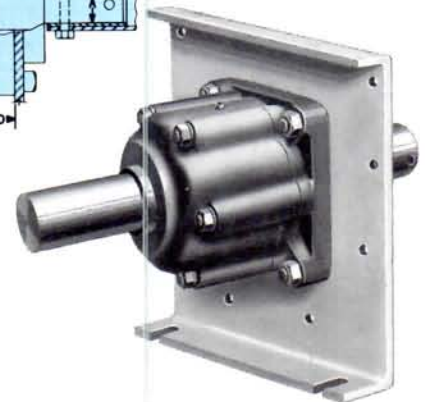
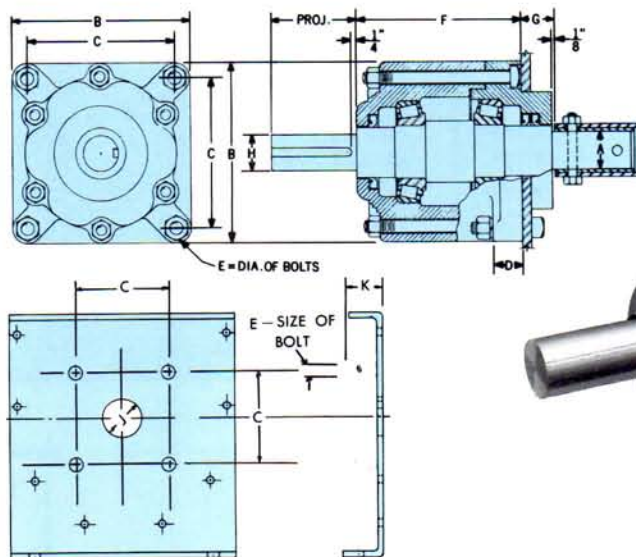

## Bronze Washer Type End Thrust

Shaft Size A	STYLE No. BW-1		STYLE No. BW-2		B	ΔC	Washer Thickness Each
	*Part Number	Weight Per Set	●Part Number	Weight Per Set			
1	275-0149	¾	275-0560	½	.75	.549	¼
1½	275-0214	1	275-0636	¾	.75	.560	¼
2	275-0289	1½	275-0701	1	.75	.572	¼
27/16	275-0354	2¼	275-0776	1½	.75	.591	¼
3	275-0420	3	275-0842	2	.75	.608	¼
37/16	275-0495	3	275-0917	2	.75	.608	¼

● The assembly consists of one bronze and two steel washers.  
▲ This assembly consists of one machined bronze washer, one steel washer, the Truarc Ring and precision machined ring groove in shaft.

For drive and end shaft dimensions see page 13.  
▲ This dimension is from the face of trough end hub bearing to the outside of thrust ring groove on the end shaft.

### Inside Style No. BW-1

Mounted inside the conveyor trough at the inlet end, this inexpensive assembly handles light to moderate compression thrust loads. It consists of a transmission bronze washer flanked on each side by a machined steel washer.

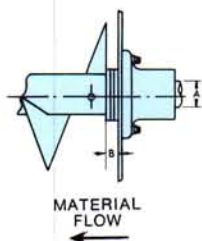

### Outside Style No. BW-2

Mounted at the discharge end of the conveyor, this assembly handles light tension thrust loads. The transmission bronze washer is held in place, between the faced trough end bearing hub and a machined steel washer, by a Tru-Arc Thrust Ring.

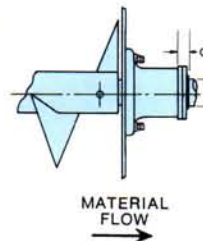





# Double Flanged Trough

DIMENSIONS IN INCHES AND AVERAGE WEIGHTS IN POUNDS									
Diameter of Conveyor	Trough Thickness	Size Code	5 Ft. Part Number	10 Ft. Part Number	A	B	C	D	Wgt. Per Foot
4	16	4DF16	301-0931	301-0998	5	1 <sup>9</sup> / <sub>16</sub>	8 <sup>1</sup> / <sub>8</sub>	3 <sup>5</sup> / <sub>8</sub>	4
4	14	4DF14	301-1053	301-1103	5	1 <sup>9</sup> / <sub>16</sub>	8 <sup>1</sup> / <sub>8</sub>	3 <sup>5</sup> / <sub>8</sub>	5
6	16	6DF16	301-0220	301-1210	7	1 <sup>7</sup> / <sub>16</sub>	9 <sup>7</sup> / <sub>8</sub>	4 <sup>1</sup> / <sub>2</sub>	5
6	14	6DF14	301-1319	301-1327	7	1 <sup>7</sup> / <sub>16</sub>	9 <sup>7</sup> / <sub>8</sub>	4 <sup>1</sup> / <sub>2</sub>	6
6	10	6DF10	301-1384	301-1434	7	1 <sup>7</sup> / <sub>16</sub>	9 <sup>7</sup> / <sub>8</sub>	4 <sup>1</sup> / <sub>2</sub>	11
9	14	9DF14	301-0337	301-1541	10	1 <sup>13</sup> / <sub>16</sub>	13 <sup>5</sup> / <sub>8</sub>	6 <sup>1</sup> / <sub>8</sub>	9
9	12	9DF12	301-1640	301-1657	10	1 <sup>13</sup> / <sub>16</sub>	13 <sup>5</sup> / <sub>8</sub>	6 <sup>1</sup> / <sub>8</sub>	12
9	10	9DF10	301-1756	301-1764	10	1 <sup>13</sup> / <sub>16</sub>	13 <sup>5</sup> / <sub>8</sub>	6 <sup>1</sup> / <sub>8</sub>	15
10	14	10DF14	301-1822	301-1871	11	1 <sup>13</sup> / <sub>16</sub>	14 <sup>5</sup> / <sub>8</sub>	6 <sup>3</sup> / <sub>8</sub>	9
10	12	10DF12	301-1939	301-1988	11	1 <sup>13</sup> / <sub>16</sub>	14 <sup>5</sup> / <sub>8</sub>	6 <sup>3</sup> / <sub>8</sub>	13
			6 Ft. Part Number	12 Ft. Part Number					
12	12	12DF12	301-0667	301-2861	13	2 <sup>1</sup> / <sub>4</sub>	17 <sup>1</sup> / <sub>2</sub>	7 <sup>3</sup> / <sub>4</sub>	15
12	10	12DF10	301-2960	301-2978	13	2 <sup>1</sup> / <sub>4</sub>	17 <sup>1</sup> / <sub>2</sub>	7 <sup>3</sup> / <sub>4</sub>	19
14	12	14DF12	301-0774	301-3083	15	2 <sup>1</sup> / <sub>4</sub>	19 <sup>1</sup> / <sub>2</sub>	9 <sup>1</sup> / <sub>4</sub>	18
14	10	14DF10	301-3117	301-3190	15	2 <sup>1</sup> / <sub>4</sub>	19 <sup>1</sup> / <sub>2</sub>	9 <sup>1</sup> / <sub>4</sub>	23
16	12	16DF12	301-0881	301-3307	17	2 <sup>1</sup> / <sub>4</sub>	21 <sup>1</sup> / <sub>2</sub>	10 <sup>5</sup> / <sub>8</sub>	20
16	10	16DF10	301-3406	301-3414	17	2 <sup>1</sup> / <sub>4</sub>	21 <sup>1</sup> / <sub>2</sub>	10 <sup>5</sup> / <sub>8</sub>	25
18	12	18DF12	301-3463	301-3497	19	2 <sup>3</sup> / <sub>4</sub>	24 <sup>1</sup> / <sub>2</sub>	12 <sup>1</sup> / <sub>8</sub>	23
18	10	18DF10	301-3513	301-3521	19	2 <sup>3</sup> / <sub>4</sub>	24 <sup>1</sup> / <sub>2</sub>	12 <sup>1</sup> / <sub>8</sub>	28
20	10	20DF10	301-3620	301-3638	21	2 <sup>3</sup> / <sub>4</sub>	26 <sup>1</sup> / <sub>2</sub>	13 <sup>1</sup> / <sub>2</sub>	31
24	10	24DF10	301-2655	301-3745	25	2 <sup>3</sup> / <sub>4</sub>	30 <sup>1</sup> / <sub>2</sub>	16 <sup>1</sup> / <sub>2</sub>	37

The unique design of the Double Flanged Trough adds considerably to its strength and structural rigidity without adding to its weight. In addition, this construction provides an effective dust-tight seal when used with the "Barron" Flanged Cover. Double Flanged Troughs are available in sizes up to 24" and in gauges up to 10. They can be formed of stainless steel or other alloys. Nu-Weld end flanges are continuously jig-welded on each end to assure alignment and tight connecting joints. If supporting feet are needed, they are spaced at the flange joints. Trough saddles are also available, see page 56.

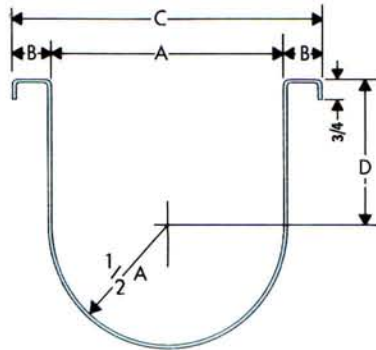





# Barron Flanged Covers

DIMENSIONS IN INCHES AND AVERAGE WEIGHTS IN POUNDS								
Size of Conveyor	"BARRON" COVER COMPLETE WITH CLAMPS AND GASKET							"BARRON" CLAMPS ONLY
	Gauge of Steel	Size Code	5 Ft. Part Number	10 Ft. Part Number	A	B	Wgt. per Ft.	Part Number
4	16	4BC16	310-0286	310-3107	5	1 <sup>5</sup> / <sub>8</sub>	2	320-0227
6	16	6BC16	310-3033	310-3124	7	1 <sup>1</sup> / <sub>2</sub>	2.5	320-0334
9	14	9BC14	310-3181	310-3231	10	1 <sup>7</sup> / <sub>8</sub>	4	320-0441
10	14	10BC14	310-0617	310-3348	11	1 <sup>7</sup> / <sub>8</sub>	4.2	320-0557
			6 Ft. Part Number	12 Ft. Part Number				
12	14	12BC14	310-3355	310-3454	13	2 <sup>5</sup> / <sub>16</sub>	5	320-0664
14	14	14BC14	310-1185	310-3561	15	2 <sup>5</sup> / <sub>16</sub>	5.5	320-0771
16	14	16BC14	310-3686	310-3678	17	2 <sup>5</sup> / <sub>16</sub>	6	320-0888
18	12	18BC12	310-1409	310-3785	19	2 <sup>13</sup> / <sub>16</sub>	9.5	320-0995
20	12	20BC12	310-1508	310-3892	21	2 <sup>13</sup> / <sub>16</sub>	10.2	320-1100
24	12	24BC12	310-1649	310-4007	25	2 <sup>13</sup> / <sub>16</sub>	11.2	320-1217

The Barron Cover is designed for use with a double flanged trough. It is not weather-tight but the gaskets between the cover and trough and under the Barron clamps do provide a degree of weather protection. For greater protection battens can be mounted lapping the cover joints. The cover should then be bolted or screw clamped. Flanged covers can also be used with angle troughs in which case they should be bolted or screw clamped.

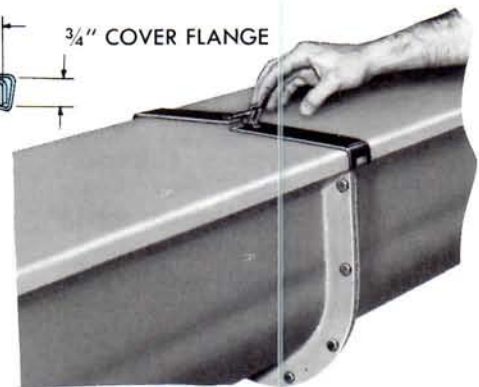
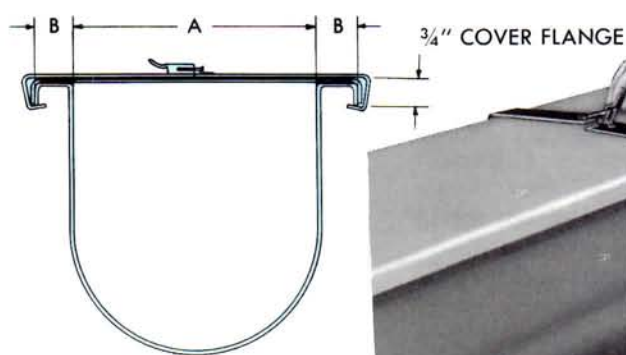





# Angle Trough

DIMENSIONS IN INCHES AND AVERAGE WEIGHTS IN POUNDS																		
Size of Conveyor	Trough Thickness	Size Code	5 Ft. Part Number	10 Ft. Part Number	Wgt. Per Ft.	A	B Size of Angles	C	Size of Conveyor	Trough Thickness	Size Code	6 Ft. Part Number	12 Ft. Part Number	Wgt. Per Ft.	A	B Size of Angles	C	
4	14	4AT14	305-1315	305-1323	7	5	1 1/4 x 1 1/4 x 3/16	3 3/8	14	12	14AT12	305-0994	305-4400	21	15	2 x 2 x 3/16	9 1/4	
	6	14	6AT14	305-1521	305-1547	9	7	1 1/4 x 1 1/4 x 3/16		4 1/2	10	14AT10	305-4459	305-4517				25
		10	6AT10	305-1638	305-1653	12					3/16	14AT07	305-4608	305-4624				32
9	14	9AT14	305-1745	305-1760	11	10	1 1/2 x 1 1/2 x 3/16	6 1/8	16	12	16AT12	305-1109	305-4848	23	17	2 x 2 x 3/16	10 3/8	
	12	9AT12	305-1828	305-1877	14					10	16AT10	305-4905	305-4954	28				
	10	9AT10	305-1901	305-1984	17					3/16	16AT07	305-5027	305-5068	36				
10	14	10AT14	305-2180	305-2206	12	11	1 1/2 x 1 1/2 x 3/16	6 3/8	18	12	18AT12	305-5241	305-5258	28	19	2 1/2 x 2 1/2 x 1/4	12 1/8	
	12	10AT12	305-2289	305-2313	15					10	18AT10	305-5274	305-5282	34				
	3/16	10AT03	305-2149	305-2156	27					3/16	18AT07	305-5381	305-5399	43				
12	14	12AT14	305-2404	305-2420	23	13	2 x 2 x 3/16	7 3/4	20	10	20AT10	305-5589	305-5613	37	21	2 1/2 x 2 1/2 x 1/4	13 1/2	
	12	12AT12	305-3972	305-3964	19					3/16	20AT07	305-5688	305-5720	47				
	10	12AT10	305-4087	305-4079	22					1/4	20AT03	305-5803	305-5837	60				
12	12	12AT12	305-3972	305-3964	19	13	2 x 2 x 3/16	7 3/4	24	10	24AT10	305-5902	305-5944	42	25	2 1/2 x 2 1/2 x 1/4	16 1/2	
	10	12AT10	305-4087	305-4079	22					3/16	24AT07	305-6009	305-6058	55				
	3/16	12AT07	305-4137	305-4186	28					1/4	24AT03	305-6116	305-6165	70				
12	14	12AT14	305-4251	305-4293	36	13	2 x 2 x 3/16	7 3/4	24	10	12AT03	305-4251	305-4293	36	25	2 1/2 x 2 1/2 x 1/4	16 1/2	
	12	12AT12	305-3972	305-3964	19					3/16	24AT07	305-6009	305-6058	55				
	10	12AT10	305-4087	305-4079	22					1/4	24AT03	305-6116	305-6165	70				

Angle Trough is fitted with structural steel angles along the top edge of the trough to provide excellent strength and rigidity in all trough sizes and gauges. "Nu-Weld" end flanges are continuously jig-welded to each end to assure alignment and tight connecting joints. Angle Trough can be formed of hot rolled steel, stainless steel or other alloys in all sizes and gauges, and may be hot dip galvanized. Trough modification such as a perforated bottom, a drop bottom for sanitary installations, jacketing for heating or cooling, etc., are available. Although normally furnished with a Tite-Seal Cover other types such as the Dome, Flanged, Hip Roof, etc., are available (see page 54). If supporting feet are needed, they are mounted at the flange joints. Trough saddles are also available, see page 56.

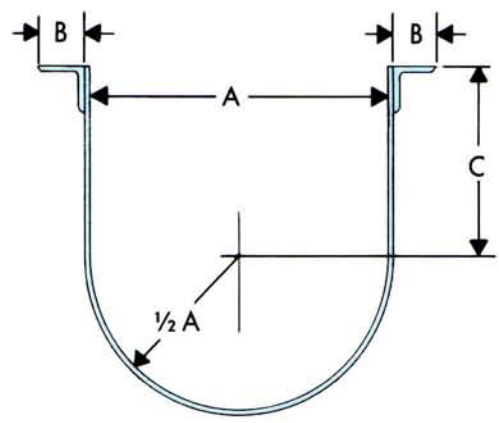





# Tite-Seal Covers

DIMENSIONS IN INCHES AND AVERAGE WEIGHTS IN POUNDS										
Size of Conveyor	TITE-SEAL COVER WITH CLAMPS AND "U" EDGING							TITE-SEAL CLAMPS ONLY	"U" EDGING ONLY	
	Gauge of Steel	Size Code	5 Ft. Part Number	10 Ft. Part Number	A*	B	Wgt. per Ft.	Part Number	Size Number	Part Number
4	16	4TS16	312-0185	312-2017	7 <sup>3</sup> / <sub>4</sub>	1 <sup>1</sup> / <sub>4</sub>	1.6	322-0225	1	330-0142
6	16	6TS16	312-0300	312-2124	9 <sup>3</sup> / <sub>4</sub>	1 <sup>1</sup> / <sub>4</sub>	2.0	322-0332	1	330-0142
9	14	9TS14	312-2165	312-2231	13 <sup>1</sup> / <sub>4</sub>	1 <sup>1</sup> / <sub>2</sub>	3.4	322-0449	1	330-0142
10	14	10TS14	312-0508	312-2348	14 <sup>1</sup> / <sub>4</sub>	1 <sup>1</sup> / <sub>2</sub>	3.7	322-0555	1	330-0142
			6 Ft. Part Number	12 Ft. Part Number						
12	14	12TS14	312-1027	312-2454	17 <sup>1</sup> / <sub>4</sub>	2	4.6	322-0662	1	330-0217
14	14	14TS14	312-1183	312-2561	19 <sup>1</sup> / <sub>4</sub>	2	5.2	322-0779	1	330-0217
16	14	16TS14	312-1274	312-2678	21 <sup>1</sup> / <sub>4</sub>	2	5.8	322-0886	1	330-0217
18	12	18TS12	312-1407	312-2785	24 <sup>1</sup> / <sub>4</sub>	2 <sup>1</sup> / <sub>2</sub>	8.7	322-0993	2	330-0357
20	12	20TS12	312-1506	312-2892	26 <sup>1</sup> / <sub>4</sub>	2 <sup>1</sup> / <sub>2</sub>	9.5	322-1108	2	330-0357
24	12	24TS12	312-1621	312-2900	30 <sup>1</sup> / <sub>4</sub>	2 <sup>1</sup> / <sub>2</sub>	11.1	322-1215	2	330-0357

\* For trough thickness 16 Ga. through 10 Ga. For use with trough thickness of 3/16" through 1/4" increase 1/4".

**Tite-Seal Covers are designed for use with Angle Trough.** They provide a high degree of dust protection. The flat cover is held securely in place by a continuous formed steel "U" edging along both sides of the trough. This "U" edging is fitted with sponge rubber and seals the cover to the trough. Tite-Seal quick-release cover clamps hold the entire assembly in place and yet allow quick access to the trough interior. A gasket attached to the underside of the cover clamp seals the joint between lengths of cover.

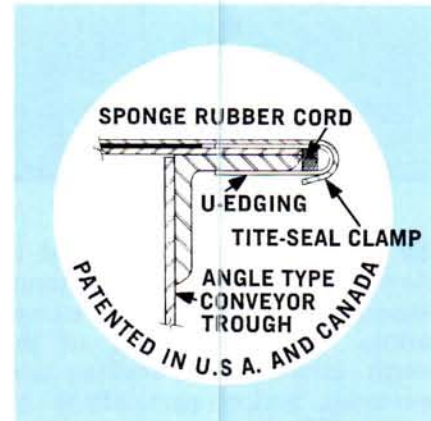
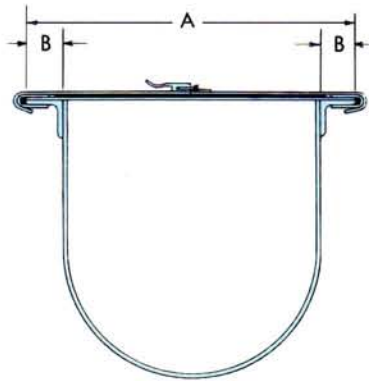





# Flared Trough

## DIMENSIONS IN INCHES AND AVERAGE WEIGHTS IN POUNDS

Size of Conveyor	Trough Thickness	Size Code	Part Number 10 Ft.	A	B	C	D	E	Weight Per Foot
6	14 3/16	6FT14	308-0223	14	16 5/8	7	5 5/8	3 1/2	8
		6FT07	308-0330	14	16 5/8	7	5 5/8	3 1/2	19
9	14 10 3/16 1/4	9FT14	308-0447	18	21 1/2	9	7 7/8	5	11
		9FT10	308-0553	18	21 1/2	9	7 7/8	5	19
		9FT07	308-0660	18	21 1/2	9	7 7/8	5	26
		9FT03	308-0777	18	21 1/2	9	7 7/8	5	34
			<b>Part Number 12 Ft.</b>						
12	12 10 3/16 1/4	12FT12	308-0884	22	26 1/2	10	9 5/8	6 1/2	21
		12FT10	308-0991	22	26 1/2	10	9 5/8	6 1/2	27
		12FT07	308-1106	22	26 1/2	10	9 5/8	6 1/2	37
		12FT03	308-1213	22	26 1/2	10	9 5/8	6 1/2	49
14	12 10 3/16 1/4	14FT12	308-1320	24	28 1/2	11	10 7/8	7 1/2	23
		14FT10	308-1437	24	28 1/2	11	10 7/8	7 1/2	30
		14FT07	308-1544	24	28 1/2	11	10 7/8	7 1/2	41
		14FT03	308-1650	24	28 1/2	11	10 7/8	7 1/2	55
16	12 10 3/16 1/4	16FT12	308-1767	28	32 1/2	11 1/2	12	8 1/2	26
		16FT10	308-1874	28	32 1/2	11 1/2	12	8 1/2	33
		16FT07	308-1981	28	32 1/2	11 1/2	12	8 1/2	44
		16FT03	308-2096	28	32 1/2	11 1/2	12	8 1/2	59
18	10 3/16 1/4	18FT10	308-2203	31	36 1/2	12 1/8	13 3/8	9 1/2	36
		18FT07	308-2310	31	36 1/2	12 1/8	13 3/8	9 1/2	49
		18FT03	308-2427	31	36 1/2	12 1/8	13 3/8	9 1/2	65
20	10 3/16 1/4	20FT10	308-2534	34	39 1/2	13 1/2	15	10 1/2	38
		20FT07	308-2641	34	39 1/2	13 1/2	15	10 1/2	52
		20FT03	308-2757	34	39 1/2	13 1/2	15	10 1/2	69
24	10 3/16 1/4	24FT10	308-2864	40	45 1/2	16 1/2	18 1/8	12 1/2	44
		24FT07	308-2971	40	45 1/2	16 1/2	18 1/8	12 1/2	60
		24FT03	308-3086	40	45 1/2	16 1/2	18 1/8	12 1/2	79

The Flared Trough is designed to allow the standard 1/2" clearance between the screw and the trough bottom. The flared sides of the trough improve the feeding and conveying action particularly on materials that are not entirely free-flowing or material in large slabs or pieces. The top edges are flanged to provide cover support and Nu-Weld steel end flanges are continuously jig-welded to each end to assure alignment and tight joints. Where conditions require special construction, Flared Troughs may be furnished in stainless steel, Monel or other alloys. Covers are usually bolted on or furnished with screw or spring clamps and may be flat for interior or hip roof for exterior installations.

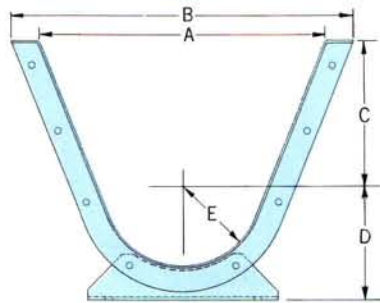





# Special Trough Designs

## Channel Trough

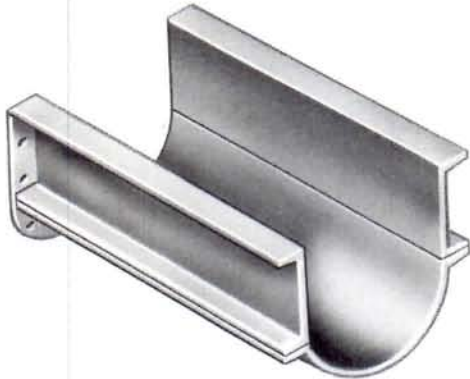

Channel Trough is made with a separate rolled or formed steel bottom for use where severe abrasion or corrosion factors require frequent trough replacements. The bottom is bolted to the structural steel side channels making a very rigid unit that can be used where trough supports are necessarily widely spaced.

## Jacketed Trough

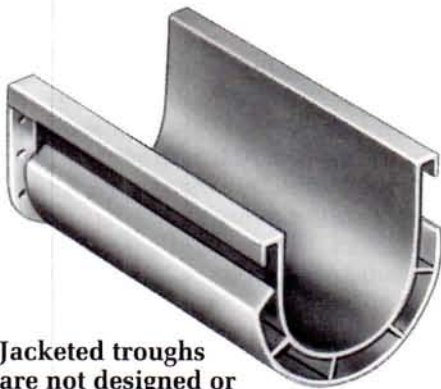

**Jacketed troughs are not designed or constructed to be pressure vessels.**

The Jacketed Trough is used to carry an agent for heating, cooling or drying the material while it is being conveyed. A formed jacket is continuously welded to a standard trough. This trough may be built to various standards; therefore, please consult our staff engineers before ordering.

## Dust Seal Trough

Dust Seal Troughs are formed with "Z" bars along the top sides and channels across the top width. This forms a continuous pocket into which the flanged (all four sides) cover fits. This pocket can then be filled with sand, sponge rubber or the material being conveyed, to provide a dust-tight seal that will allow quick access to the trough interior.



## Tite-Seal™ Drop Bottom Trough

The Tite-Seal Drop Bottom Trough is designed to facilitate quick access to the Screw Conveyor and trough interior where frequent cleaning is required to combat infestation and contamination or build-up of some materials. The trough is equipped with a hinged bottom section that swings open when the clamps are disengaged. The edges of the opening are gasketed to seal when closed. The Tite-Seal Drop Bottom Trough may be of single or double flanged type construction and fitted with your choice of cover.

- Hinge side and latch side are adjustable to secure seal.
- Product pressure points are reinforced to prevent leakage.
- Drop bottom fits standard troughs of 10 Ga. and heavier thickness.

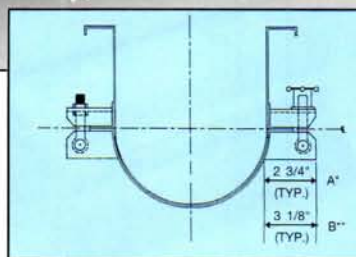
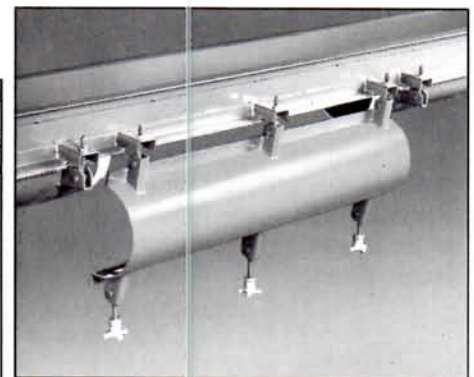
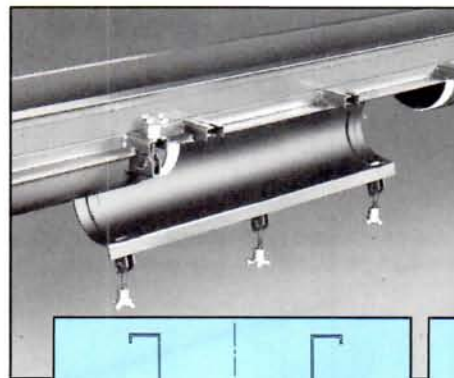

A = Dimensions for 6", 9", 10" and 12" units  
B = All larger sizes

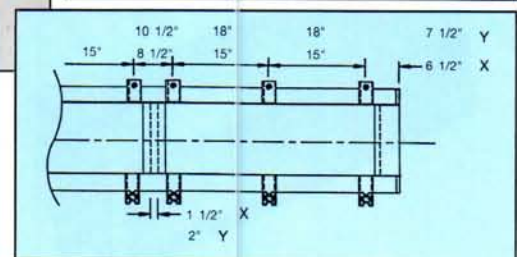

X = Dimensions for 6", 9", and 10" units.  
Y = Dimensions for 12", 14", 16", 18", 20", and 24" units.





# Additional Trough Covers & Shrouds

DIMENSIONS IN INCHES AND AVERAGE WEIGHT IN POUNDS															
Diameter of Conveyor	SEMI-FLANGED FLAT COVER				HIP ROOF COVER			SHROUDS				A	B	C	D
	5 Ft. Part Number	10 Ft. Part Number	Weight Per Foot	Gauge of Steel	5 Ft. Part Number	10 Ft. Part Number	Weight Per Foot	Length	Part Number	Gauge of Steel	Weight				
4"	314-0167	314-0225	1.6	16	316-0173	316-0223	2	8"	318-0254	12	3.8	5	3 3/8	8 5/8	8 1/4
6"	314-0274	314-0332	2.0	16	316-0306	316-0330	2.5	12"	318-0023	12	7.5	7	4 1/2	10 1/2	10
9"	314-0381	314-0449	3.4	14	316-0579	316-0553	4	18"	318-0049	10	20.5	10	6 1/8	14 1/2	13 3/4
10"	314-0613	314-0662	3.7	14	316-0629	316-0660	4.2	20"	318-0544	10	24.0	11	6 3/8	15 1/4	14 3/4
	6 Ft. Part Number	12 Ft. Part Number			6 Ft. Part Number	12 Ft. Part Number									
12"	314-0688	314-0779	4.6	14	316-0751	316-1106	5	24"	318-0080	10	35	13	7 3/4	18 1/8	17 1/8
14"	314-0803	314-0886	5.2	14	316-0850	316-1213	5.5	28"	318-0767	10	49	15	9 1/4	20 1/2	19 1/8
16"	314-0936	314-0993	5.8	14	316-0959	316-1320	6	32"	318-0841	10	65	17	10 5/8	22 1/2	21 1/8
18"	314-1041	314-1108	8.7	12	316-1023	316-1437	9.5	36"	318-0981	10	85	19	12 1/8	25 1/2	24 1/8
20"	314-1157	314-1215	9.5	12	316-1502	316-1544	10.2	40"	318-1096	10	105	21	13 1/2	27 1/2	26 1/8
24"	314-1264	314-1322	11.1	12	316-1635	316-1650	11.2	48"	318-1203	10	153	25	16 1/2	31 1/2	30 1/8

Semi-Flanged Covers

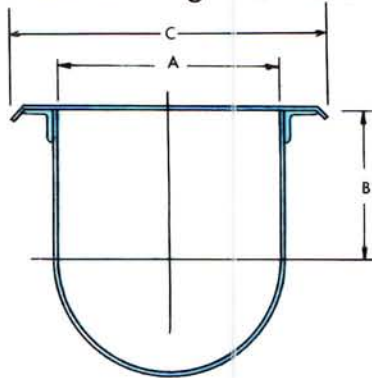

Hip Roof Covers

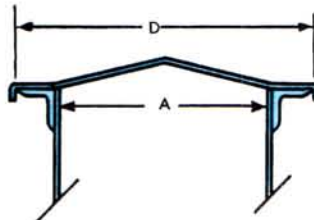

Shrouds

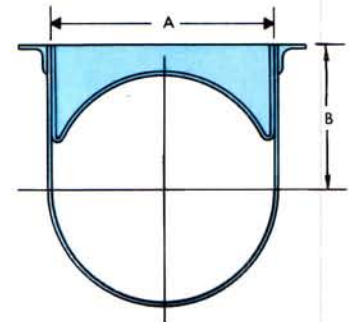

Semi-Flanged covers are flat covers with a slight crimp on both sides for greater strength and rigidity. They can be fastened by bolts, spring or screw clamps. They are not considered weather-proof but through the addition of gaskets and battens at the cover joints a reasonably tight construction can be obtained.

Hip Roof covers are intended for outdoor applications. The cover is flanged down on both sides and fitted with battens at the cover joints. Rubber gaskets are usually furnished all around. Fastening is usually by bolting but screw clamps can also be supplied.

Shrouds are incorporated in feeder conveyors to baffle the flow of material. Shrouds are also designed to fit inside a standard trough to create a tubular effect for inclined operation. Covers of any construction are then used over shrouds as required.

Note: Standard designs are not intended to be weather, rain, air, or pressure tight. For special design requirements, contact your nearest sales office.





# Trough Cover Clamps

## Spring Cover Clamp

Steel Spring Cover Clamps are commonly used to fasten flat or semi-flanged covers to the conveyor trough. For dust-tight applications, they may also be fitted over a gasketed cover. Spring Cover Clamps are usually located on 2'6" centers, if gasketed, 15" centers, or closer to suit.

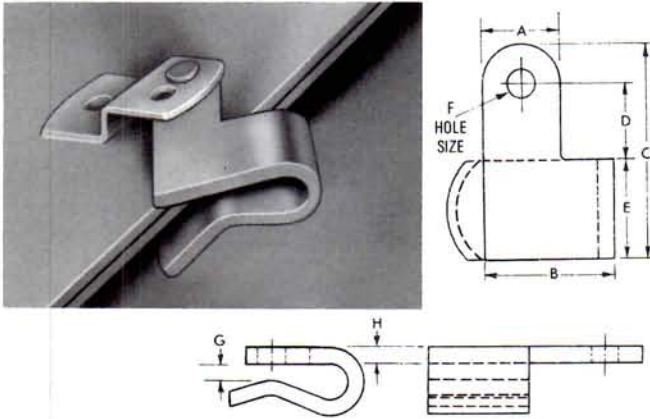

Size Code	Part Number	A	B	C	D	E	F	G	H	Wgt. Per C
1SC	325-0669	7/8	1 <sup>9</sup> / <sub>16</sub>	2 <sup>1</sup> / <sub>8</sub>	1 <sup>1</sup> / <sub>16</sub>	1 <sup>1</sup> / <sub>4</sub>	9/32	5/32"	3/16	34
2SC	325-1105	1 <sup>1</sup> / <sub>8</sub>	1 <sup>15</sup> / <sub>16</sub>	3 <sup>1</sup> / <sub>4</sub>	1 <sup>1</sup> / <sub>8</sub>	1 <sup>1</sup> / <sub>2</sub>	13/32	1/4"	3/16	51

\*Part Numbers shown are for clamps for riveting to side angle of trough, if to include bracket for welding to cover as pictured add suffix "B".

## Screw Cover Clamp

Screw Clamps may be used for flat or other special trough covers and are usually located on 30" centers or if gasketed, 15" centers, or closer to suit. Screw Clamps are also often used to clamp the bottom of drop bottom troughs.

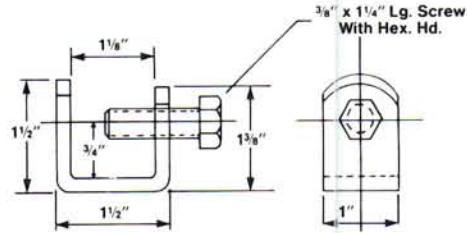

Part Number	Weight Per C
323-0711	25#

## Continuous Cover Clamps

The Continuous Cover Clamp is a heavy-gauge spring clamp furnished in 5' lengths. It is ideally suited to fastening a flat cover to the conveyor trough or for fastening a drop-bottom or quick-opening trough or casing section. The Continuous Clamp can be supplied in black iron or stainless steel, with or without locking pins on the ends.

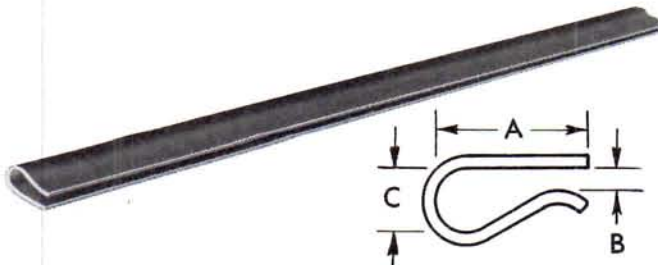

Size Code	Part Number	A	B	C	Weight Each
4CC 5'-0" Length	323-0554	1 <sup>1</sup> / <sub>4</sub>	3/16	1/2	6

## Quick-Release Clamps

See pages 49 and 51 for "Barron" and "Tite-Seal" cover clamps.



"BARRON" Cover Clamp



"TITE-SEAL" COVER CLAMP





# Supporting Feet and Saddles

DIMENSIONS IN INCHES AND AVERAGE WEIGHTS IN POUNDS																			
Diameter of Conveyor	NU-WELD END FLANGE			SUPPORTING FOOT		SADDLE		A	B	C	D	E	F	G	H	J	L	M	
	Part No. Light Trough	Part No. Heavy Trough	Wgt.	Part Number	Wgt.	Part Number	Wgt.											Size	No.
4	332-0223	--	1½	335-0147	1½	337-0145	1½	5¼	8	3⅝	¾	4⅝	¾	5¾	7/8	1½	¾	¾	6
6	332-0330	332-1767	2	335-0212	2	337-0210	2	7¼	9¾	4½	¾	5⅝	¾	8⅛	7/8	1½	¾	¾	6
9	332-0447	332-1874	3	335-0287	4½	337-0285	4½	10¼	13½	6⅞	¾	7⅞	¾	9⅞	1⅞	2½	½	¾	8
10	332-0553	332-1981	4	335-0352	5	337-0350	5	11¼	14½	6⅞	¾	8⅞	¾	9½	1⅞	2½	½	¾	8
12	332-0660	332-2096	5	335-0428	6	337-0426	6	13¼	17¼	7¾	¼	9⅞	¾	12¼	1⅞	2½	⅝	½	8
14	332-0777	332-2203	6½	335-0493	7	337-0491	7	15¼	19¼	9¼	¼	10⅞	¼	13½	1⅞	2½	⅝	½	8
16	332-0884	332-2310	7½	335-0568	7½	337-0566	8	17¼	21¼	10⅞	¼	12	¼	14⅞	1⅞	3	⅝	⅝	8
18	332-1320	332-1320	10½	335-0634	9½	337-0632	10	19¼	24¼	12⅞	¼	13⅞	¼	16	1⅞	3	⅝	⅝	10
20	332-1437	332-1437	11½	335-0709	12½	337-0707	13	21¼	26¼	13½	¼	15	¼	19¼	2	3½	¾	⅝	10
24	332-1544	332-1544	13½	335-0774	14½	337-0772	15	25¼	30¼	16½	¼	18⅞	¼	20	2¼	4	¾	⅝	12

When ordering for conveyor trough ¾" thick or heavier, show part number and specify "for heavy trough."

Supporting feet provide the means of aligning and fastening the trough to the floor or existing structure at the trough joints. The trough end height is accurately maintained and the feet permit the removal of a trough end without disturbing the entire unit.

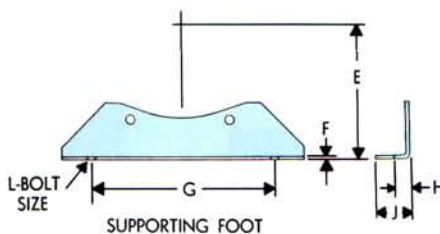

Saddles are used to support the trough between the trough sections and fasten to the floor or existing structures. The total height from the floor is the same as for a trough end with feet.

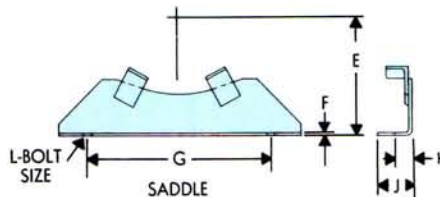

## Flanges

Nu-Weld End Flanges are made of heavy-gauge steel to assure a close accurate fit with the conveyor trough and the trough ends or the following end flange. Bolt holes are jig-punched to assure accurate alignment.

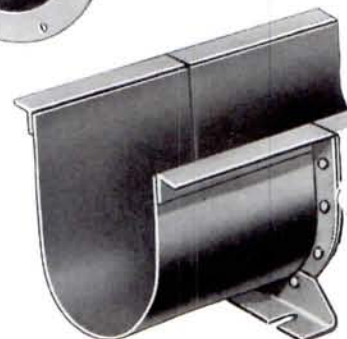
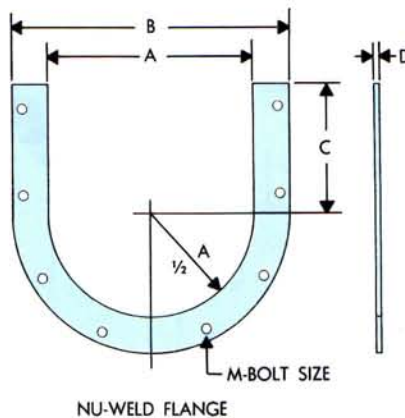





# Feed and Discharge Spouts

DIMENSIONS IN INCHES AND AVERAGE WEIGHTS IN POUNDS																
Diameter of Conveyor	Gauge of Steel	Without HAND SLIDE		With HAND SLIDE		A	B	C	G-H	J	K	L	M	N	P	R
		Part Number	Wgt.	Part Number	Wgt.											
4	14	342-0148	2	342-1823	6	5	4 1/2	3 3/4	7 1/2	11 1/8	3/8	2 1/4		2 1/4	1/4	1 1/8
6	14	342-0213	4	342-1898	10	7	6	5	10	14 1/8	1 1/16	2 13/16		3	3/8	1 3/8
9	14	342-0353	7	342-1963	16	10	8	7 1/8	13	18 3/4	1/2	4		4	3/8	2
	10	342-0429	12	342-2037	21	10	8	7 1/8	13	18 3/4	1/2	4		4	3/8	2
10	14	342-0494	8	342-2102	19	11	9	7 7/8	14 1/4	20 1/8	5/8	4 5/16		4 3/8	3/8	2 1/4
	10	342-0569	14	342-2177	25	11	9	7 7/8	14 1/4	20 1/8	5/8	4 5/16		4 3/8	3/8	2 1/4
12	12	342-0635	15	342-2243	33	13	10 1/2	8 7/8	17 1/4	24 1/2	7/8	5 1/8		5 1/4	3/8	2 1/4
	3/16	342-0700	27	342-2318	45	13	10 1/2	8 7/8	17 1/4	24 1/2	7/8	5 1/8		5 1/4	3/8	2 1/4
14	12	342-0775	19	342-2383	41	15	11 1/2	10 1/8	19 1/4	27 5/8	7/8	3 1/2	3 1/2	3 1/2	3/8	2 1/2
	3/16	342-0841	34	342-2458	56	15	11 1/2	10 1/8	19 1/4	27 5/8	7/8	3 1/2	3 1/2	3 1/2	3/8	2 1/2
16	12	342-0916	23	342-2524	49	17	13 1/2	11 1/8	21 1/4	30 3/4	7/8	3 3/4	4	4	3/8	2 1/2
	3/16	342-0981	38	342-2599	64	17	13 1/2	11 1/8	21 1/4	30 3/4	7/8	3 3/4	4	4	3/8	2 1/2
18	12	342-1054	30	342-2664	64	19	14 1/2	12 3/8	24 1/4	33 3/4	1 1/8	4 7/16	4 3/8	4 3/8	1/2	2 3/4
	3/16	342-1120	52	342-2730	86	19	14 1/2	12 3/8	24 1/4	33 3/4	1 1/8	4 7/16	4 3/8	4 3/8	1/2	2 3/4
20	12	342-1195	34	342-2805	84	21	15 1/2	13 3/8	26 1/4	36 3/4	1 1/8	4 7/8	4 3/4	4 3/4	1/2	2 3/4
	3/16	342-1260	59	342-2870	109	21	15 1/2	13 3/8	26 1/4	36 3/4	1 1/8	4 7/8	4 3/4	4 3/4	1/2	2 3/4
24	12	342-1336	44	342-2946	108	25	17 1/2	15 3/8	30 1/4	42 7/8	1 1/8	5 5/8	5 5/8	5 1/2	1/2	3
	3/16	342-1401	76	342-3019	140	25	17 1/2	15 3/8	30 1/4	42 7/8	1 1/8	5 5/8	5 5/8	5 1/2	1/2	3

• Part Numbers shown apply to discharge spouts only.  
For feed spout indicate size & gauge EXAMPLE: one 12" 3/16" thk feed spout or 14" 12 GA feed spout.

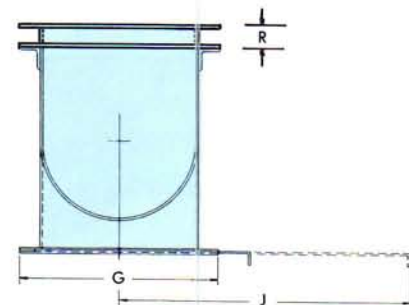
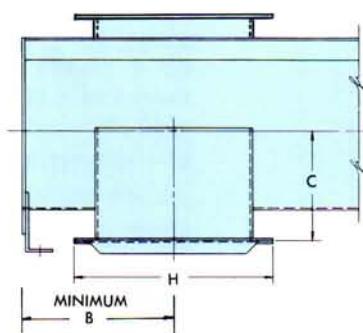
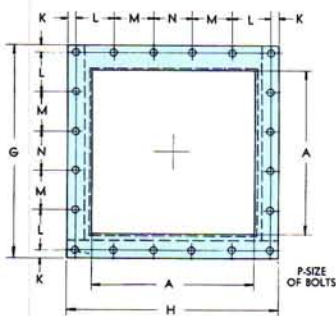

Stub spouts with or without slide gates are fitted to conveyor trough or cover openings. The slide may be mounted on either a feed or discharge spout and may be operated parallel to the trough or at right angles, as required. Spouts of special dimensions, gauges and materials can be supplied to suit installation needs.

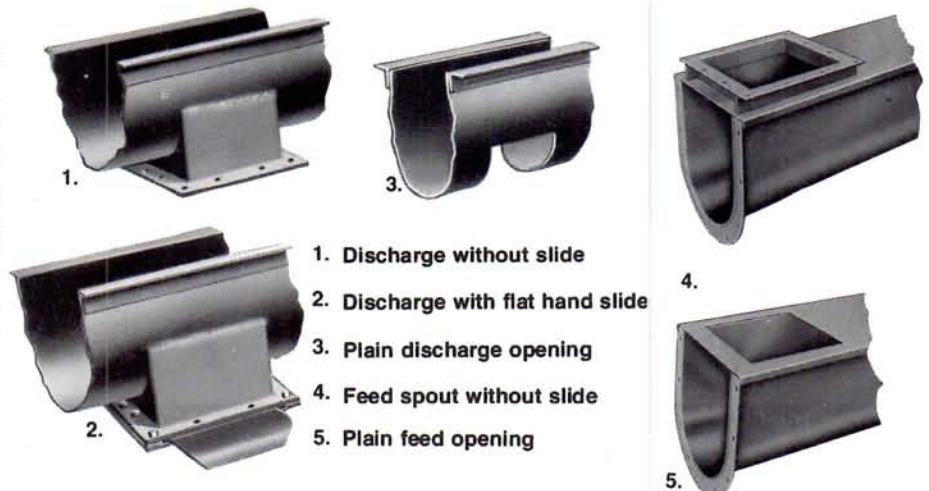





# Rack and Pinion Gates

DIMENSIONS IN INCHES AND AVERAGE WEIGHTS IN POUNDS															
Diameter of Conveyor	Gauge of Spout	CURVED SLIDE		A	B	C	D	E	F	G (Ga.)	H	J	K	L	M
		Part Number	Wgt.												
6	14	350-0212	38	7 <sup>1</sup> / <sub>4</sub>	10 <sup>1</sup> / <sub>4</sub>	8	11 <sup>5</sup> / <sub>8</sub>	14	7 <sup>5</sup> / <sub>8</sub>	12	11 <sup>5</sup> / <sub>8</sub>	12	12	27 <sup>1</sup> / <sub>16</sub>	15 <sup>5</sup> / <sub>8</sub>
	12	350-0287	40	7 <sup>1</sup> / <sub>4</sub>	10 <sup>1</sup> / <sub>4</sub>	8	11 <sup>5</sup> / <sub>8</sub>	12	7 <sup>5</sup> / <sub>8</sub>	12	11 <sup>3</sup> / <sub>8</sub>	12	12	27 <sup>1</sup> / <sub>16</sub>	15 <sup>5</sup> / <sub>8</sub>
9	12	350-0352	48	10 <sup>1</sup> / <sub>4</sub>	13 <sup>1</sup> / <sub>4</sub>	9 <sup>1</sup> / <sub>2</sub>	13 <sup>1</sup> / <sub>8</sub>	12	9 <sup>1</sup> / <sub>8</sub>	12	12 <sup>15</sup> / <sub>16</sub>	12	12	27 <sup>1</sup> / <sub>16</sub>	20 <sup>1</sup> / <sub>8</sub>
	10	350-0428	53	10 <sup>1</sup> / <sub>4</sub>	13 <sup>1</sup> / <sub>4</sub>	9 <sup>1</sup> / <sub>2</sub>	13 <sup>1</sup> / <sub>8</sub>	10	9 <sup>1</sup> / <sub>8</sub>	12	12 <sup>15</sup> / <sub>16</sub>	12	12	27 <sup>1</sup> / <sub>16</sub>	20 <sup>1</sup> / <sub>8</sub>
10	12	350-0493	61	11 <sup>1</sup> / <sub>4</sub>	14 <sup>1</sup> / <sub>4</sub>	10	13 <sup>5</sup> / <sub>8</sub>	12	9 <sup>5</sup> / <sub>8</sub>	10	13 <sup>7</sup> / <sub>16</sub>	12	12	27 <sup>1</sup> / <sub>16</sub>	21 <sup>1</sup> / <sub>8</sub>
	10	350-0568	66	11 <sup>1</sup> / <sub>4</sub>	14 <sup>1</sup> / <sub>4</sub>	10	13 <sup>5</sup> / <sub>8</sub>	10	9 <sup>5</sup> / <sub>8</sub>	10	13 <sup>7</sup> / <sub>16</sub>	12	12	27 <sup>1</sup> / <sub>16</sub>	21 <sup>1</sup> / <sub>8</sub>
12	10	350-0634	81	13 <sup>1</sup> / <sub>4</sub>	17 <sup>1</sup> / <sub>4</sub>	11	15 <sup>5</sup> / <sub>8</sub>	10	10 <sup>5</sup> / <sub>8</sub>	10	14 <sup>7</sup> / <sub>16</sub>	12	12	27 <sup>1</sup> / <sub>16</sub>	24 <sup>5</sup> / <sub>8</sub>
	3/16	350-0709	94	13 <sup>1</sup> / <sub>4</sub>	17 <sup>1</sup> / <sub>4</sub>	11	15 <sup>5</sup> / <sub>8</sub>	3/16	10 <sup>5</sup> / <sub>8</sub>	10	14 <sup>7</sup> / <sub>16</sub>	12	12	27 <sup>1</sup> / <sub>16</sub>	24 <sup>5</sup> / <sub>8</sub>
*14	10	350-0774	99	15 <sup>1</sup> / <sub>4</sub>	19 <sup>1</sup> / <sub>4</sub>	10 <sup>13</sup> / <sub>16</sub>	17 <sup>5</sup> / <sub>8</sub>	10	11 <sup>5</sup> / <sub>8</sub>	10	15 <sup>7</sup> / <sub>16</sub>	12	12	2 <sup>5</sup> / <sub>8</sub>	27 <sup>5</sup> / <sub>8</sub>
	3/16	350-0840	118	15 <sup>1</sup> / <sub>4</sub>	19 <sup>1</sup> / <sub>4</sub>	10 <sup>13</sup> / <sub>16</sub>	17 <sup>5</sup> / <sub>8</sub>	3/16	11 <sup>5</sup> / <sub>8</sub>	10	15 <sup>7</sup> / <sub>16</sub>	12	12	2 <sup>5</sup> / <sub>8</sub>	27 <sup>5</sup> / <sub>8</sub>
*16	10	350-0915	115	17 <sup>1</sup> / <sub>4</sub>	21 <sup>1</sup> / <sub>4</sub>	11 <sup>13</sup> / <sub>16</sub>	20 <sup>5</sup> / <sub>8</sub>	10	12 <sup>5</sup> / <sub>8</sub>	10	16 <sup>7</sup> / <sub>16</sub>	12	12	2 <sup>5</sup> / <sub>8</sub>	30 <sup>5</sup> / <sub>8</sub>
	3/16	350-0980	138	17 <sup>1</sup> / <sub>4</sub>	21 <sup>1</sup> / <sub>4</sub>	11 <sup>13</sup> / <sub>16</sub>	20 <sup>5</sup> / <sub>8</sub>	3/16	12 <sup>5</sup> / <sub>8</sub>	10	16 <sup>7</sup> / <sub>16</sub>	12	12	2 <sup>5</sup> / <sub>8</sub>	30 <sup>5</sup> / <sub>8</sub>
*18	10	350-1053	150	19 <sup>1</sup> / <sub>4</sub>	24 <sup>1</sup> / <sub>4</sub>	12 <sup>13</sup> / <sub>16</sub>	22 <sup>5</sup> / <sub>8</sub>	10	13 <sup>5</sup> / <sub>8</sub>	10	17 <sup>7</sup> / <sub>16</sub>	12	12	2 <sup>5</sup> / <sub>8</sub>	33 <sup>5</sup> / <sub>8</sub>
	3/16	350-1129	170	19 <sup>1</sup> / <sub>4</sub>	24 <sup>1</sup> / <sub>4</sub>	12 <sup>13</sup> / <sub>16</sub>	22 <sup>5</sup> / <sub>8</sub>	3/16	13 <sup>5</sup> / <sub>8</sub>	10	17 <sup>7</sup> / <sub>16</sub>	12	12	2 <sup>5</sup> / <sub>8</sub>	33 <sup>5</sup> / <sub>8</sub>
*20	10	350-1194	160	21 <sup>1</sup> / <sub>4</sub>	26 <sup>1</sup> / <sub>4</sub>	13 <sup>7</sup> / <sub>8</sub>	24 <sup>5</sup> / <sub>8</sub>	10	14 <sup>5</sup> / <sub>8</sub>	3/16	18 <sup>7</sup> / <sub>16</sub>	12	12	2 <sup>5</sup> / <sub>8</sub>	36 <sup>5</sup> / <sub>8</sub>
	3/16	350-1269	183	21 <sup>1</sup> / <sub>4</sub>	26 <sup>1</sup> / <sub>4</sub>	13 <sup>7</sup> / <sub>8</sub>	24 <sup>5</sup> / <sub>8</sub>	3/16	14 <sup>5</sup> / <sub>8</sub>	3/16	18 <sup>7</sup> / <sub>16</sub>	12	12	2 <sup>5</sup> / <sub>8</sub>	36 <sup>5</sup> / <sub>8</sub>
*24	10	350-1335	202	25 <sup>1</sup> / <sub>4</sub>	30 <sup>1</sup> / <sub>4</sub>	15 <sup>7</sup> / <sub>8</sub>	29 <sup>5</sup> / <sub>8</sub>	10	16 <sup>5</sup> / <sub>8</sub>	3/16	20 <sup>7</sup> / <sub>16</sub>	12	12	2 <sup>5</sup> / <sub>8</sub>	42 <sup>5</sup> / <sub>8</sub>
	3/16	350-1400	235	25 <sup>1</sup> / <sub>4</sub>	30 <sup>1</sup> / <sub>4</sub>	15 <sup>7</sup> / <sub>8</sub>	29 <sup>5</sup> / <sub>8</sub>	3/16	16 <sup>5</sup> / <sub>8</sub>	3/16	20 <sup>7</sup> / <sub>16</sub>	12	12	2 <sup>5</sup> / <sub>8</sub>	42 <sup>5</sup> / <sub>8</sub>

\* These sizes furnished with double rack and pinions.

## Curved Slide

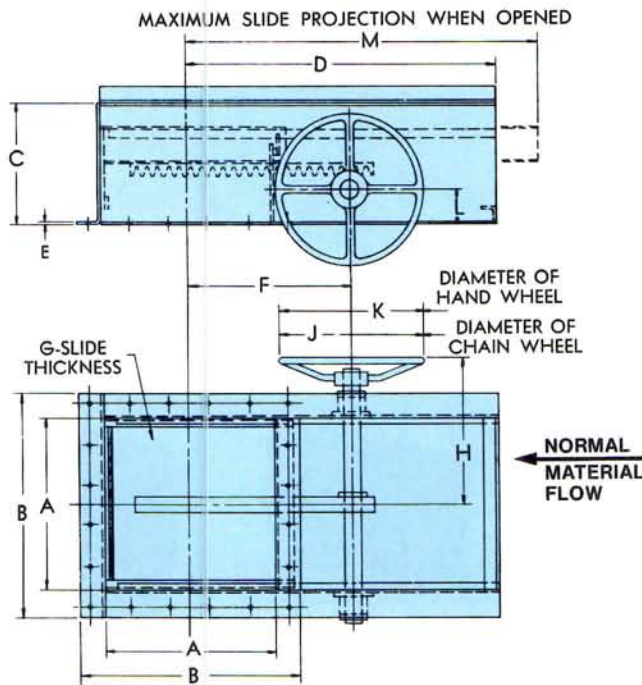

See page 57 for flange punching.

Rack and Pinion discharge gates with curved slides have cut tooth racks welded to the curved slide plate. This engages a cut tooth pinion mounted on a pinion shaft. Operation of the gate is by means of a hand wheel as illustrated. Chain wheels with chain can be supplied if desired. Curved slides conform with the contour of the trough and eliminate all pockets that might trap the material in a spout above a flat slide.

These slides can also be power operated through electric motors or air or hydraulic cylinders. Consult our engineering department for details.

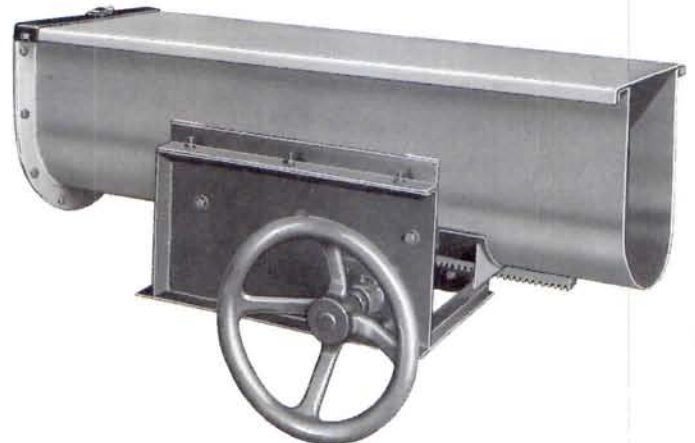





# Rack and Pinion Gates

DIMENSIONS IN INCHES AND AVERAGE WEIGHTS IN POUNDS															
Diameter of Conveyor	Gauge of Spout	Flat Side Gate		A	B	C	D	E	F	G (Ga.)	H	J	K	L	M
		Part Number	Wgt.												
4	14	350-1541	35	5	7½	5	10½	14	6½	10	10⅞	12	12	2	12½
6	14	350-1681	41	7	10	5	11½	14	7½	10	11⅜	12	12	2	15½
9	14	350-1756	52	10	13	5	13	14	9	10	10 <sup>15</sup> / <sub>16</sub>	12	12	2	20
	10	350-1822	64	10	13	5	13	10	9	10	10 <sup>15</sup> / <sub>16</sub>	12	12	2	20
10	14	350-1897	56	11	14¼	5	13½	14	9½	10	13 <sup>7</sup> / <sub>16</sub>	12	12	2	21½
	10	350-1962	70	11	14¼	5	13½	10	9½	10	13 <sup>7</sup> / <sub>16</sub>	12	12	2	21½
12	12	350-2036	79	13	17¼	5	15½	12	10½	3/16	14 <sup>7</sup> / <sub>16</sub>	12	12	2	24½
	3/16	350-2101	105	13	17¼	5	15½	3/16	10½	3/16	14 <sup>7</sup> / <sub>16</sub>	12	12	2	24½
*14	12	350-2176	94	15	19¼	5	17½	12	11½	3/16	15 <sup>7</sup> / <sub>16</sub>	12	12	2	27½
	3/16	350-2242	125	15	19¼	5	17½	3/16	11½	3/16	15 <sup>7</sup> / <sub>16</sub>	12	12	2	27½
*16	12	350-2317	106	17	21¼	5	20½	12	12½	3/16	16 <sup>7</sup> / <sub>16</sub>	12	12	2	30½
	3/16	350-2382	150	17	21¼	5	20½	3/16	12½	3/16	16 <sup>7</sup> / <sub>16</sub>	12	12	2	30½
*18	12	350-2457	131	19	24¼	5	22½	12	13½	3/16	17 <sup>7</sup> / <sub>16</sub>	12	12	2	33½
	3/16	350-2523	147	19	24¼	5	22½	3/16	13½	3/16	17 <sup>7</sup> / <sub>16</sub>	12	12	2	33½
*20	12	350-2598	152	21	26¼	5	24½	12	14½	3/16	18 <sup>7</sup> / <sub>16</sub>	12	12	2	36½
	3/16	350-2663	202	21	26¼	5	24½	3/16	14½	3/16	18 <sup>7</sup> / <sub>16</sub>	12	12	2	36½
*24	12	350-2739	176	25	30¼	5	29½	12	16½	3/16	20 <sup>7</sup> / <sub>16</sub>	12	12	2	42½
	3/16	350-2804	240	25	30¼	5	29½	3/16	16½	3/16	20 <sup>7</sup> / <sub>16</sub>	12	12	2	42½

\* These sizes furnished with double racks and pinions.

## Flat Slide

Rack and Pinion discharge gates with flat slides have cut tooth racks welded to the slide plate. This engages a cut tooth pinion which is mounted on a pinion shaft. Operation of the gate is by means of a hand wheel, as illustrated, but chain wheels with chain can be supplied if desired. Flat slides allow operation in any one of the four positions if clearance is adequate. These slides can also be power operated through electric motors, air or hydraulic cylinders. Consult our engineering department for details.

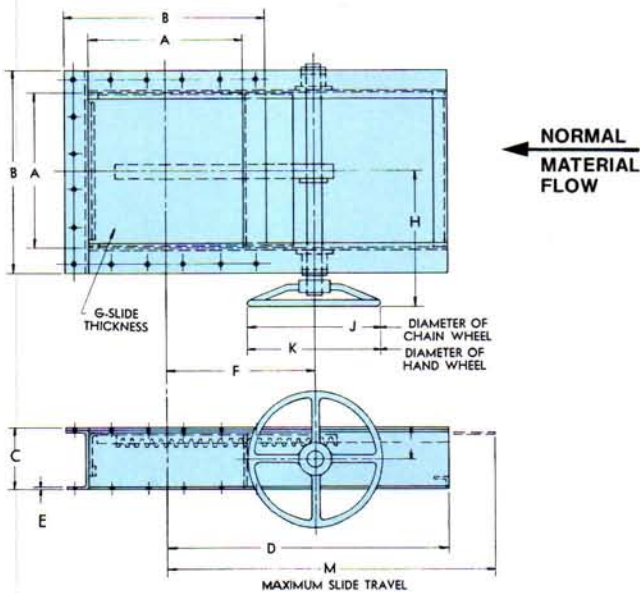

See page 57 for flange punching.







# Flush End Discharge

DIMENSIONS IN INCHES					
Diameter of Conveyor	A	B	Diameter of Conveyor	A	B
4	3 $\frac{1}{4}$	5	14	10 $\frac{1}{8}$	15
6	5	7	16	11 $\frac{1}{8}$	17
9	7 $\frac{1}{8}$	10	18	12 $\frac{3}{8}$	19
10	7 $\frac{3}{8}$	11	20	13 $\frac{3}{8}$	21
12	8 $\frac{1}{8}$	13	24	15 $\frac{3}{8}$	25

A discharge assembly as shown on page 57 can be undesirable, if material has a tendency to build up between the edge of the discharge opening and the inside of the trough end plate at the extreme end of the conveyor. To overcome this, the spout can be mounted flush with the end of the trough and the trough end modified to act as the fourth side of the discharge spout. The trough end may be any of the types shown on pages 41 through 44.

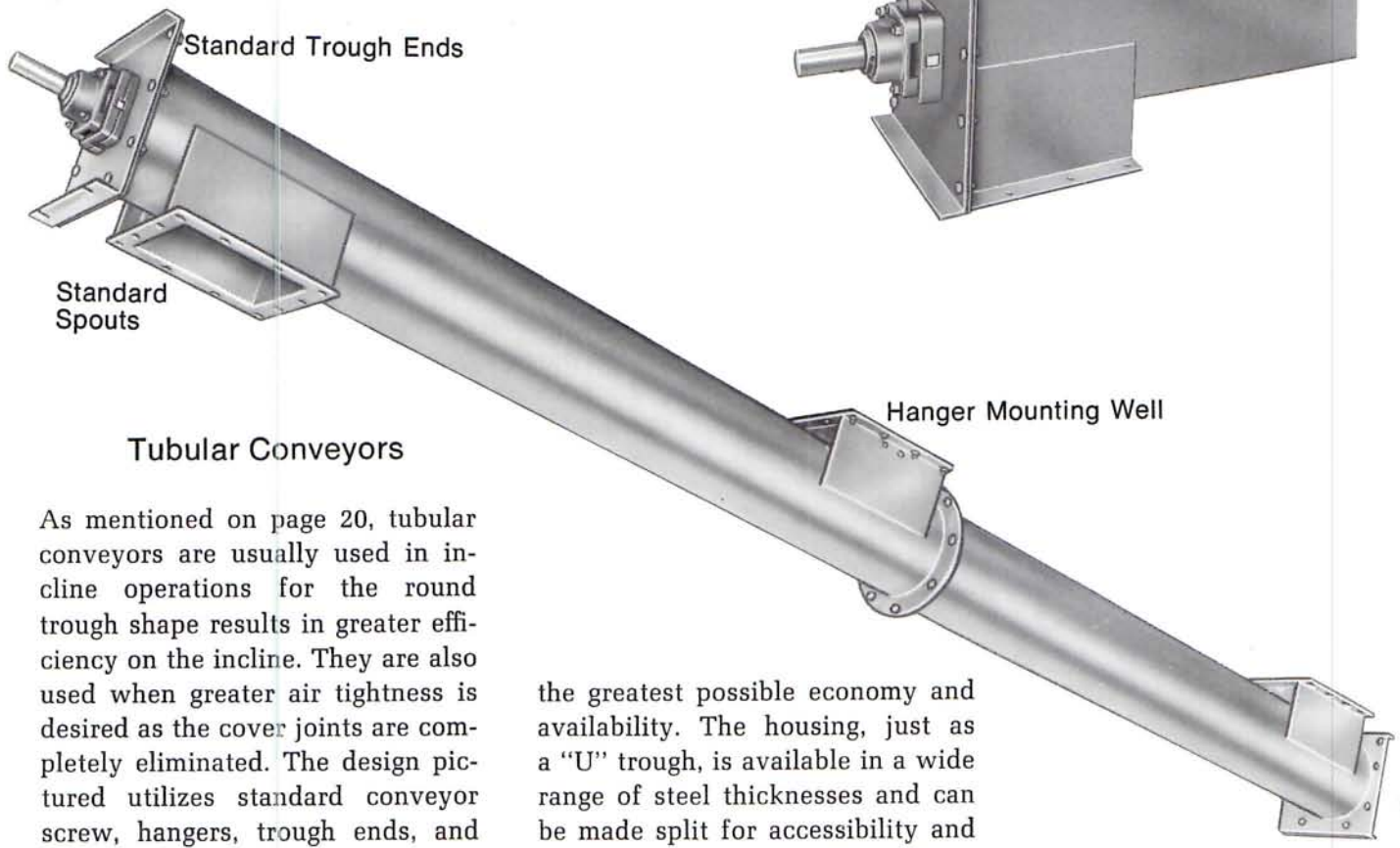
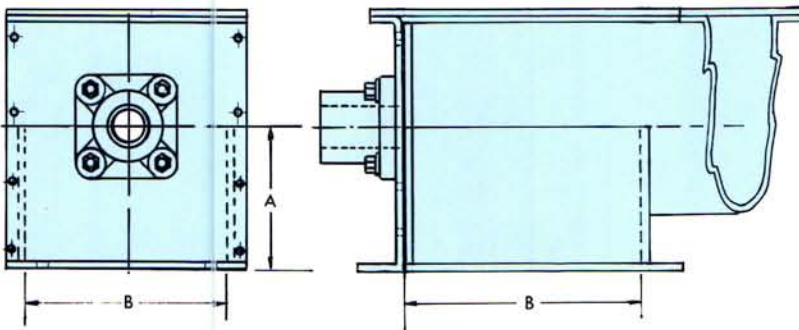

## Tubular Conveyors

As mentioned on page 20, tubular conveyors are usually used in in-line operations for the round trough shape results in greater efficiency on the incline. They are also used when greater air tightness is desired as the cover joints are completely eliminated. The design pictured utilizes standard conveyor screw, hangers, trough ends, and spouts as shown in this catalog for

the greatest possible economy and availability. The housing, just as a "U" trough, is available in a wide range of steel thicknesses and can be made split for accessibility and drop bottom or top for cleaning.





# Assembly Bolts

**Coupling Bolts** are normally "Tem-U-Lac" as pictured on page 34.

**Assembly Bolts** for hangers, trough flanges, trough ends, bolted covers and supporting feet are normally hex head machine bolts with lock washers and hex nuts.

CONVEYOR PART	CONVEYOR AND BOLT SIZES															
	4 x 1		6 x 1 1/2		9 x 1 1/2		9 x 2		10 x 1 1/2		10 x 2		12 x 2		12 x 2 7/16	
	Bolt	No.	Bolt	No.	Bolt	No.	Bolt	No.	Bolt	No.	Bolt	No.	Bolt	No.	Bolt	No.
Conveyor Coupling	3/8 x 2 1/8	4	1/2 x 3	4	1/2 x 3	4	5/8 x 3 3/8	4	1/2 x 3	4	5/8 x 3 3/8	4	5/8 x 3 3/8	4	5/8 x 4 3/8	4
326 Hanger	3/8 x 1	4	3/8 x 1 1/4	4	3/8 x 1 1/4	4	3/8 x 1 1/4	4	3/8 x 1 1/4	4	3/8 x 1 1/4	4	1/2 x 1 1/2	4	1/2 x 1 1/2	4
216 Hanger	3/8 x 1	4	3/8 x 1 1/4	4	3/8 x 1 1/4	4	3/8 x 1 1/4	4	3/8 x 1 1/4	4	3/8 x 1 1/4	4	1/2 x 1 1/2	4	1/2 x 1 1/2	4
220 Hanger	3/8 x 1	4	3/8 x 1	4	3/8 x 1	4	3/8 x 1	4	3/8 x 1	4	3/8 x 1	4	1/2 x 1 1/4	4	1/2 x 1 1/4	4
226 Hanger	3/8 x 1	4	3/8 x 1 1/4	4	3/8 x 1 1/4	4	3/8 x 1 1/4	4	3/8 x 1 1/4	4	3/8 x 1 1/4	4	1/2 x 1 1/2	4	1/2 x 1 1/2	4
230 Hanger	3/8 x 1	4	3/8 x 1	4	3/8 x 1	4	3/8 x 1	4	3/8 x 1	4	3/8 x 1	4	1/2 x 1 1/4	4	1/2 x 1 1/4	4
260 Hanger			3/8 x 1	4	3/8 x 1	4	3/8 x 1	4	3/8 x 1	4	3/8 x 1	4	1/2 x 1 1/4	4	1/2 x 1 1/4	4
270 Hanger			3/8 x 1 1/4	4	3/8 x 1 1/4	4	3/8 x 1 1/4	4	3/8 x 1 1/4	4	3/8 x 1 1/4	4	1/2 x 1 1/2	4	1/2 x 1 1/2	4
Trough Flange	3/8 x 1	6	3/8 x 1	6	3/8 x 1	8	3/8 x 1	8	3/8 x 1	8	3/8 x 1	8	1/2 x 1 1/4	8	1/2 x 1 1/4	8
Trough End	3/8 x 1	6	3/8 x 1	6	3/8 x 1 1/4	8	3/8 x 1 1/4	8	3/8 x 1 1/4	8	3/8 x 1 1/4	8	1/2 x 1 1/2	8	1/2 x 1 1/2	8
Bolted Cover	5/16 x 1	10	5/16 x 1	10	5/16 x 1	10	5/16 x 1	10	5/16 x 1	10	5/16 x 1	10	5/16 x 1	10	5/16 x 1	10
Supporting Foot	3/8 x 1 1/4	2	3/8 x 1 1/4	2	3/8 x 1 1/4	2	3/8 x 1 1/4	2	3/8 x 1 1/4	2	3/8 x 1 1/4	2	1/2 x 1 1/2	2	1/2 x 1 1/2	2

CONVEYOR PART	CONVEYOR AND BOLT SIZES															
	12 x 3		14 x 2 7/16		14 x 3		16 x 3		18 x 3		20 x 3		20 x 3 7/16		24 x 3 7/16	
	Bolt	No.	Bolt	No.	Bolt	No.	Bolt	No.	Bolt	No.	Bolt	No.	Bolt	No.	Bolt	No.
Conveyor Coupling	3/4 x 5	4	5/8 x 4 3/8	4	3/4 x 5	4	3/4 x 5	4	3/4 x 5	4	3/4 x 5	4	5/8 x 5 1/2	4	5/8 x 5 1/2	4
326 Hanger	1/2 x 1 1/2	4	1/2 x 1 1/2	4	1/2 x 1 1/2	4	1/2 x 1 1/2	4	5/8 x 1 1/2	4	5/8 x 1 1/2	4	5/8 x 1 1/2	4	5/8 x 1 1/2	4
216 Hanger	1/2 x 1 1/2	4	1/2 x 1 3/4	4	1/2 x 1 3/4	4	1/2 x 1 3/4	4	5/8 x 1 3/4	4	5/8 x 1 3/4	4	5/8 x 1 3/4	4	5/8 x 1 3/4	4
220 Hanger	1/2 x 1 1/4	4	1/2 x 1 1/2	4	1/2 x 1 1/2	4	1/2 x 1 1/2	4	5/8 x 1 1/2	4	5/8 x 1 1/2	4	5/8 x 1 1/2	4	5/8 x 1 1/2	4
226 Hanger	1/2 x 1 1/2	4	1/2 x 1 3/4	4	1/2 x 1 3/4	4	1/2 x 1 3/4	4	5/8 x 1 3/4	4	5/8 x 1 3/4	4	5/8 x 1 3/4	4	5/8 x 1 3/4	4
230 Hanger	1/2 x 1 1/4	4	1/2 x 1 1/2	4	1/2 x 1 1/2	4	1/2 x 1 1/2	4	5/8 x 1 1/2	4	5/8 x 1 1/2	4	5/8 x 1 1/2	4	5/8 x 1 1/2	4
260 Hanger	1/2 x 1 1/4	4	1/2 x 1 1/2	4	1/2 x 1 1/2	4	1/2 x 1 1/2	4	5/8 x 1 1/2	4	5/8 x 1 1/2	4	5/8 x 1 1/2	4	5/8 x 1 1/2	4
270 Hanger	1/2 x 1 1/2	4	1/2 x 1 3/4	4	1/2 x 1 3/4	4	1/2 x 1 3/4	4	5/8 x 1 3/4	4	5/8 x 1 3/4	4	5/8 x 1 3/4	4	5/8 x 1 3/4	4
Trough Flange	1/2 x 1 1/4	8	1/2 x 1 1/4	8	1/2 x 1 1/4	8	5/8 x 1 3/4	8	5/8 x 1 3/4	10	5/8 x 1 3/4	10	5/8 x 1 3/4	10	5/8 x 1 3/4	12
Trough End	1/2 x 1 1/2	8	1/2 x 1 1/2	8	1/2 x 1 1/2	8	5/8 x 1 3/4	8	5/8 x 1 3/4	10	5/8 x 1 3/4	10	5/8 x 1 3/4	10	5/8 x 1 3/4	12
Bolted Cover	5/16 x 1	10	5/16 x 1	10	5/16 x 1	10	5/16 x 1	10	5/16 x 1	10	5/16 x 1	10	5/16 x 1	10	5/16 x 1	10
Supporting Foot	1/2 x 1 1/2	2	1/2 x 1 1/2	2	1/2 x 1 1/2	2	5/8 x 1 3/4	2	5/8 x 1 3/4	2	5/8 x 1 3/4	2	5/8 x 1 3/4	2	5/8 x 1 3/4	2





# Weights & Dimensions

## PIPE SIZES NORMALLY USED IN ASSEMBLY OF CONVEYOR SCREW

### STANDARD WEIGHT STEEL PIPE

DIMENSIONS IN INCHES AND AVERAGE WEIGHTS IN POUNDS									
Nominal Pipe Size	△ACTUAL SIZE		Wall Thickness	†Weight Per Foot	Nominal Pipe Size	△ACTUAL SIZE		Wall Thickness	†Weight Per Foot
	OD	ID				OD	ID		
¼	.405	.269	.068	.244	5	5.563	5.047	.258	14.617
¼	.540	.364	.088	.424	6	6.625	6.065	.280	18.974
¾	.675	.493	.091	.567					
½	.840	.622	.109	.850	*7	7.625	7.023	.301	23.544
					8	8.625	8.071	.277	24.696
¾	1.050	.824	.113	1.130	8	8.625	7.981	.322	28.554
1	1.315	1.049	.133	1.678	*9	9.625	8.941	.342	33.907
1¼	1.660	1.380	.140	2.272					
1½	1.900	1.610	.145	2.717	10	10.750	10.192	.279	31.201
					10	10.750	10.136	.307	34.240
2	2.375	2.067	.154	3.652	10	10.750	10.020	.365	40.483
2½	2.875	2.469	.203	5.793	*11	11.750	11.000	.375	45.557
3	3.500	3.068	.216	7.575					
3½	4.000	3.548	.226	9.109	12	12.754	12.090	.330	43.773
					12	12.750	12.000	.375	49.562
4	4.500	4.026	.237	10.790					
*4½	5.000	4.506	.247	12.538					

### EXTRA HEAVY STEEL PIPE

DIMENSIONS IN INCHES AND AVERAGE WEIGHTS IN POUNDS									
Nominal Pipe Size	△ACTUAL SIZE		Wall Thickness	†Weight Per Foot	Nominal Pipe Size	△ACTUAL SIZE		Wall Thickness	†Weight Per Foot
	OD	ID				OD	ID		
¼	.405	.215	.095	.314	5	5.563	4.813	.375	20.778
¼	.540	.302	.119	.535					
¾	.675	.423	.126	.738	6	6.625	5.761	.432	28.573
½	.840	.546	.147	1.087					
¾	1.050	.742	.154	1.473	*7	7.625	6.625	.500	38.048
					8	8.625	7.625	.500	43.388
1	1.315	.957	.179	2.171					
1¼	1.660	1.278	.191	2.996	*9	9.625	8.625	.500	48.728
1½	1.900	1.500	.200	3.631					
2	2.375	1.939	.218	5.022	10	10.750	9.750	.500	54.735
2½	2.875	2.323	.276	7.661	*11	11.750	10.750	.500	60.075
3	3.500	2.900	.300	10.252					
3½	4.000	3.364	.318	12.505	12	12.750	11.750	.500	65.415
4	4.500	3.826	.337	14.983					
*4½	5.000	4.290	.355	17.611					

\*These sizes are listed but not commonly used.

†Permissible variations in weight is plus or minus 5%.

△Subject to standard mill tolerance variations

### DOUBLE EXTRA HEAVY STEEL PIPE

DIMENSIONS IN INCHES AND AVERAGE WEIGHTS IN POUNDS									
Nominal Pipe Size	△ACTUAL SIZE		Wall Thickness	†Weight Per Foot	Nominal Pipe Size	△ACTUAL SIZE		Wall Thickness	†Weight Per Foot
	OD	ID				OD	ID		
½	.840	.252	.294	1.714	4	4.500	3.152	.674	27.541
¾	1.050	.434	.308	2.440	*4½	5.000	3.580	.710	32.530
1	1.315	.599	.358	3.659	5	5.563	4.063	.750	38.552
1¼	1.660	.896	.382	5.214					
1½	1.900	1.100	.400	6.408	6	6.625	4.897	.864	53.160
2	2.375	1.503	.436	9.029	*7	7.625	5.875	.875	63.079
2½	2.875	1.771	.552	13.695					
					8	8.625	6.875	.875	72.424
3	3.500	2.300	.600	18.583					
3½	4.000	2.728	.636	22.850					

\*These sizes are listed but not commonly used.

†Permissible variations in weight is plus or minus 5%.

△Subject to standard mill tolerance variations





# Weights & Dimensions

## STANDARD SHEET GAUGES

DIMENSIONS IN INCHES AND WEIGHTS IN POUNDS PER SQUARE FOOT									
Gauge	MFR'S STD.—STEEL SHEETS U.S. STD.—REVISED			BIRMINGHAM WIRE (BWG) STUBS IRON WIRE		Galvanized Sheet	STAINLESS SHEETS OLD U.S. STD.		
	Fractional	Decimal	Weight	Decimal	Weight		Decimal	Chr. Iron	Chr. Nickel
8	11/64	.1644	6.875	.165	6.7320				
9	5/32	.1495	6.250	.148	6.0384				
10	9/64	.1345	5.625	.134	5.4672	5.781	.1406	5.794	5.906
11	1/8	.1196	5.000	.120	4.8960	5.156	.1250	5.150	5.250
12	7/64	.1046	4.375	.109	4.4472	4.531	.1094	4.506	4.594
13	3/32	.0897	3.750	.095	3.8760	3.906	.0938	3.863	3.938
14	5/64	.0747	3.125	.083	3.3864	3.281	.0781	3.219	3.281
15	9/128	.0673	2.812	.072	2.9376	2.969	.0703	2.897	2.953
16	1/16	.0598	2.500	.065	2.6510	2.656	.0625	2.575	2.625
17	9/160	.0538	2.250	.058	2.3664	2.406	.0563	2.318	2.363
18	1/20	.0478	2.000	.049	1.9992	2.156	.0500	2.060	2.100
19	7/160	.0418	1.750	.042	1.7126	1.906	.0438	1.803	1.838
20	3/80	.0359	1.500	.035	1.4280	1.656	.0375	1.545	1.575
21	11/320	.0329	1.375	.032	1.3056	1.531	.0344	1.416	1.444
22	1/32	.0299	1.250	.028	1.1424	1.406	.0313	1.288	1.313
23	9/320	.0269	1.125	.025	1.0206	1.281	.0281	1.159	1.181
24	1/40	.0239	1.000	.022	.8970	1.156	.0250	1.030	1.050
25	7/320	.0209	.875	.020	.8160	1.031	.0219	.901	.919
26	3/160	.0179	.750	.018	.7344	.906	.0188	.773	.788
27	11/640	.0164	.687	.016	.6528	.844	.0172	.708	.722
28	1/64	.0149	.625	.014	.5712	.781	.0156	.644	.656
29	9/640	.0135	.562	.013	.5304	.719	.0141	.579	.591
30	1/80	.0120	.500	.012	.4896	.656	.0125	.515	.525

## WEIGHTS OF STEEL PLATES

DIMENSIONS IN FRACTIONAL INCHES AND WEIGHTS IN POUNDS PER SQUARE FOOT							
STEEL PLATES				STAINLESS STEEL PLATES			
Thickness	Weight	Thickness	Weight	Thickness	Weight	Thickness	Weight
3/16	7.65	1 1/8	45.90	3/16	8.295	7/16	18.810
1/4	10.20	1 1/4	51.00	19/64	8.984	15/32	20.155
5/16	12.75	1 3/8	56.10	7/32	9.677	1/2	21.498
3/8	15.30	1 1/2	61.20	15/64	10.369	5/16	24.185
7/16	17.85	1 3/4	66.30	1/4	10.956	3/8	26.614
1/2	20.40	1 7/8	71.40	11/64	11.641	11/16	29.276
5/8	22.95	2	81.60	9/32	12.442	3/4	31.937
3/4	25.50	2 1/4	91.80	5/16	13.437	7/8	34.599
7/8	30.60	2 1/2	102.00	11/32	14.779	1 1/8	37.260
1	35.70	2 3/4	112.20	3/8	16.123	1 1/4	39.922
	40.80	3	122.40	11/32	17.467	1 1/2	42.582

## WEIGHTS OF ROUND AND SQUARE STEEL BARS

Size in Inches	Round Weight in Lbs.	Square Weight in Lbs.	Size in Inches	Round Weight in Lbs.	Square Weight in Lbs.	Size in Inches	Round Weight in Lbs.	Square Weight in Lbs.
3/16	.094	.120	1 1/4	3.380	4.303	3	24.03	30.60
1/8	.1277	.1620	1 1/2	3.766	4.795	3 1/4	28.21	35.91
5/16	.167	.213	1 3/4	4.172	5.313	3 1/2	32.71	41.65
3/8	.2133	.2676	1 7/8	4.600	5.857	3 3/4	37.55	47.81
7/16	.261	.332	2	5.049	6.428	4	42.73	54.40
1/2	.3137	.3992	2 1/4	5.518	7.026	4 1/4	48.23	61.41
5/8	.376	.478	2 1/2	6.008	7.650	4 1/2	54.07	68.85
3/4	.4377	.5562	2 3/4	6.519	8.301	4 3/4	60.25	76.71
7/8	.511	.651	3	7.051	8.978	5	66.76	85.00
1	.668	.850	3 1/4	8.178	10.413	5 1/4	73.60	93.71
1 1/8	.845	1.076	3 1/2	9.388	11.953	5 1/2	80.78	102.85
1 1/4	1.043	1.328	3 3/4	10.681	13.600	5 3/4	88.29	112.41
1 1/2	1.262	1.607	4	12.058	15.353	6	96.13	122.40
1 3/4	1.502	1.913	4 1/4	13.519	17.213	6 1/2	112.82	143.65
1 7/8	1.763	2.245	4 1/2	15.062	19.178	7	130.85	166.60
2	2.044	2.603	4 3/4	16.690	21.250	7 1/2	150.21	191.25
2 1/8	2.347	2.988	5	18.400	23.428	8	170.90	217.60
2 1/4	2.670	3.400	5 1/4	20.195	25.713	8 1/2	192.93	245.65
2 1/2	3.015	3.838	5 1/2	22.072	28.103	9	216.30	275.40

## AREAS AND VOLUMES

- Circumference of circle ..... = 3.1416 × diameter
- Diameter of circle ..... = 0.3183 × circumference
- Side of a square of equal area ..... = 0.8862 × diameter
- Diameter of a circle of equal area ..... = 1.1284 × side of square
- Area of a circle ..... = 0.7854 × square of the diameter
- Diameter of a circle ..... = 1.1284 × square root of the area
- Surface area of a sphere ..... = 3.1416 × square of the diameter
- Volume of a sphere ..... = 0.5236 × cube of diameter
- Volume of cylinder or prism ..... = area of base × height
- Volume of cone or pyramid ..... = 1/3 × area of base × height
- Volume of the frustum of a cone or pyramid ..... = 1/3 × height × (area of upper base + area of lower base + area of upper base × area of lower base.)
- Doubling the diameter of a pipe increases its volume four times; generalizing, increasing the diameter "n" times increases the volume "n<sup>2</sup>" or "n × n" times.



<b>Components, Screw Conveyors</b> .....	24-61
<b>Bearings</b> .....	39, 40, 46, 47
Hanger.....	39
Transmission flange.....	40
<b>Bolts</b> .....	34,61
Assembly.....	61
Tem-U-Lac coupling	34
<b>Clamps, cover</b> .....	49, 51, 55
Barron.....	49, 55
Continuous.....	55
Quick release.....	49, 51
Screw.....	55
Spring.....	55
Tite-seal.....	51, 55
<b>Collars, internal, pipe bushings</b> .....	33
<b>Covers trough</b> .....	49, 51, 54
Flanged.....	49
Semi-Flanged.....	54
Hip Roof.....	54
Tite-seal.....	51
<b>End thrusts</b> .....	46, 47
<b>Chevron</b> .....	46
<b>Hammond</b> .....	47
<b>Bronze washer</b> .....	47
<b>Exacta-Flo</b> .....	18
<b>Feet, supporting</b> .....	56
<b>Flanges, Nuweld trough</b> .....	56
<b>Hangers</b> .....	36-38
Flared.....	39
<b>Guards and chain casings</b> .....	21
<b>Lugs, Screw Conveyor end</b> .....	33
<b>Rigid-Flo</b> .....	20
<b>Saddles, supporting</b> .....	56
<b>Safety precautions</b> .....	24
<b>Conveyor Screws</b> .....	25-33
Abrasion resistant.....	31
Corrosion resistant.....	31
Helicoid.....	25
Reci-change.....	30
Ribbon.....	29
Sectional (butt welded).....	26
Sectional fighting.....	28
Special designs.....	32
Stainless steel.....	31
<b>Seals, trough end dust</b> .....	45
Packing.....	45
Split Gland.....	45
Pump Type.....	45
Bolt On.....	44
<b>Shafts</b> .....	34-35
Coupling.....	34
Drive.....	35
End.....	35
<b>Quick change Screws</b> .....	30
Redi change™.....	30
Enduro-Change™ split Flight coupling.....	44
<b>Shelf, bolt-on, trough end</b> .....	44
<b>Shrouds</b> .....	54
<b>Spouts, feed and discharge</b> .....	57-60
Rack and Pinion gates.....	58, 59
Curved slide.....	58
Flat side.....	59
Discharge with flat hard slide.....	57
Discharge without slide.....	57
Feed spout without slide.....	57
Plain discharge opening.....	57
Plain feed opening.....	57
Flush end.....	60
<b>Trough ends</b> .....	41-47
100.....	41
101.....	41
102.....	42
103.....	42
104.....	43
107.....	43
109.....	46
110.....	46
114.....	43
115.....	43
<b>Flared</b> .....	43
<b>Troughs</b> .....	48-53
Angle.....	50
Double Flanged.....	48
Flared.....	52
Channel.....	53
Drop Bottom, Tite Seal™.....	53
Dust Seal.....	53
Jacketed.....	53
Tubular.....	60
<b>Engineering</b> .....	8-23
<b>Conversion Factors</b> .....	62-64
<b>Drive arrangements</b> .....	21
<b>Mechanical weights and dimensions</b> .....	62, 63
<b>Screw Conveyor, Design Data</b> .....	8-17
Material analysis.....	9
Table No. 1 Maximum size of lumps.....	9
Table No. 2 "D" factors.....	9
Table No. 3 Horsepower Ratings.....	10
Table No. 4 Material classification.....	11
Table No. 5 Group component specifications.....	11
Table No. 6 Material tables.....	12, 13, 14
Table No. 7 Capacity chart.....	15
Table No. 8 Determining the "Hand".....	16
Table No. 9 Recommended arrangements.....	17
<b>Screw Conveyor Inclined</b> .....	20, 60
<b>Screw Conveyor, Tubular</b> .....	20, 60
<b>Screw Feeder</b> .....	18, 19
Table No. 10 Capacity chart.....	19
<b>Screw-Lift</b> .....	23, 23
Table No. 11 Screw-Lift Capacity chart.....	23





# Screw Conveyor Safety Practices

TO AVOID UNSAFE OR HAZARDOUS CONDITIONS, THE FOLLOWING MINIMUM PROVISIONS MUST BE STRICTLY OBSERVED.

1. (A) **SCREW CONVEYORS SHALL NEVER BE OPERATED UNLESS THE CONVEYOR HOUSING COMPLETELY ENCLOSES THE CONVEYOR MOVING ELEMENTS.** All necessary housings, covers, safety guards, railings, gratings and power transmission guards must be in place. If the conveyor is to be opened for inspection, cleaning or observation, the motor driving the conveyor is to be locked out electrically in such a manner that it cannot be started by anyone, however remote from the area unless the conveyor housing has been closed and all guards are in place. **THE HOUSINGS, COVERS AND GUARDS ARE NECESSARY TO PREVENT ANYONE FROM ENTERING, REACHING, OR FALLING INTO THE MACHINERY, WHICH MAY RESULT IN SERIOUS PERSONAL INJURY.**
- (B) If the conveyor must have an open housing as a condition of its use, the **entire open conveyor is then to be guarded by a railing, fence or rugged safety grating.**
- (C) Feed openings for shovel, front end loader or other mechanical equipment shall be constructed in such a way that the conveyor is covered by a rugged grating. If the nature of the material is such that a grating can't be used, **then the exposed section of the conveyor is to be guarded by a railing and there shall be warning signs posted.**
2. **DO NOT PLACE HANDS OR FEET IN ANY CONVEYOR OPENING, TO AVOID BEING CAUGHT BETWEEN THE ROTATING CONVEYOR SCREW AND THE CONVEYOR HOUSING.**
3. **DO NOT WALK ON CONVEYOR COVERS OR GRATINGS OR POWER TRANSMISSION GUARDS, TO AVOID FALLING INTO OR AGAINST THE ROTATING CONVEYOR SCREW.**
4. **DO NOT** poke or prod material in the conveyor with a bar or stick, **to avoid being struck by the bar or stick.**
5. **DO NOT** overload conveyor or use it for anything but its intended use.
6. **DO** practice good housekeeping

A copy of Screw Conveyor Safety and Service Instructions are shipped as part of every order.



**THE EXPERIENCE  
TO HANDLE IT RIGHT!**

## Screw Conveyor Corporation



# EXPERIENCE IN MOTION

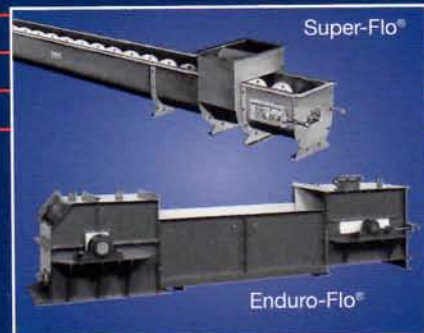
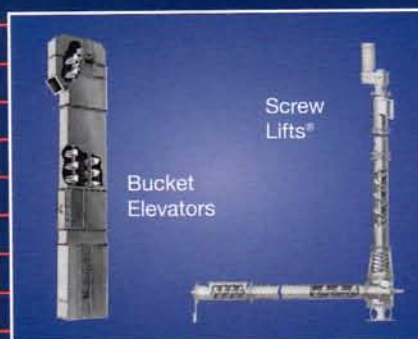

For Over 70 Years We Have Been A Dependable Source For  
Performance Proven Industrial Bulk Material Handling Equipment.  
Put Our Experience to Work for You.



THE EXPERIENCE  
TO HANDLE IT RIGHT!®

## Screw Conveyor Corporation

700 HOFFMAN STREET, HAMMOND, INDIANA 46327-1894 PHONE 219-931-1450 FAX: 800-805-6527 WEB ADDRESS: [www.screwconveyor.com](http://www.screwconveyor.com)  
Winona, MS 662-283-3142 Visalia, CA 559-651-2131 Chanute, KS 620-431-0440 Guadalajara, Jal. Mexico 011-52-333-645-7110  
FAX: 800-213-3084 FAX: 800-651-2135 FAX: 800-213-3086 FAX: 011-52-333-663-2369